

**Borrego Water District Board of Directors**  
**Special Meeting**  
**March 14, 2017 @ 9:00 a.m.**  
**806 Palm Canyon Drive**  
**Borrego Springs, CA 92004**

**I. OPENING PROCEDURES**

- A. Call to Order
- B. Pledge of Allegiance
- C. Roll Call
- D. Approval of Agenda
- E. Comments from the Public and Requests for Future Agenda Items (limited to 3 minutes)

**II. ITEMS FOR BOARD CONSIDERATION AND POSSIBLE ACTION**

- A. CLOSED SESSION (IF NECESSARY)** Initiation of litigation pursuant to paragraph (4) of subdivision (d) of Section 54956.9 – Warren Diven - BWD Bond Counsel (Best, Best and Krieger LLP)

Initiation of Proceedings to Consider the Formation of the Borrego Water District Community Facilities District No. 2017-1. (3-71)

- 1. Settlement Agreement
  - 2. Resolution of the Board of Directors of the Borrego Water District Adopting a Map Showing the Boundaries of the Territory Proposed to be Included in Borrego Water District Community Facilities District No. 2017-1
  - 3. Resolution of the Board of Directors of the Borrego Water District, Declaring its Intention to Establish Borrego Water District Community Facilities District No. 2017-1. Rate and method of apportionment of the special tax for CFD No. 2017-1 (Attached to this Resolution);
  - 4. Resolution of the Board of Directors of the Borrego Water District Declaring the Necessity to Incur a Bonded Indebtedness for Community Facilities District No. 2017-1 to be Secured by Special Taxes Levied Therein.
- B. Plans and Specifications for 900 Tank Project – D Dale (71-161)
  - C. Clarification of Policy for Water and Sewer Service to New Developments – G. Poole (162-178)
  - D. Endorsement of Candidates for ACWA/JPIA Board/Executive Committee – H Ehrlich (179)

**IV. INFORMATIONAL ITEMS (180-184)**

- A. Summary of March 6<sup>th</sup> GSP Advisory Committee Meeting – G Poole
- B. 2017 Town Hall Logistics – L Brecht (181)
- C. Risks to SGMA – L. Brecht
- D. Directors Sexual Harassment Prevention Webinar – April 2 and 6, 2017 (182)
- E. Update Depth Dependent Water Quality Sampling – G Poole
- F. Plan of Action: Risk Management Analysis – G Poole
- G. BWD Event/Planning Calendar – G Poole (183-184)

**V. CLOSED SESSION – ANTICIPATED LITIGATION**

- A.** Initiation of litigation pursuant to paragraph (4) of subdivision (d) of Section 54956.9 (1 Case)

**VI. CLOSING PROCEDURE**

- A.** Suggested Items for Next/Future Agenda
- B.** The next Meeting of the Board of Directors is scheduled for March 22, 2017 at the Borrego Water District

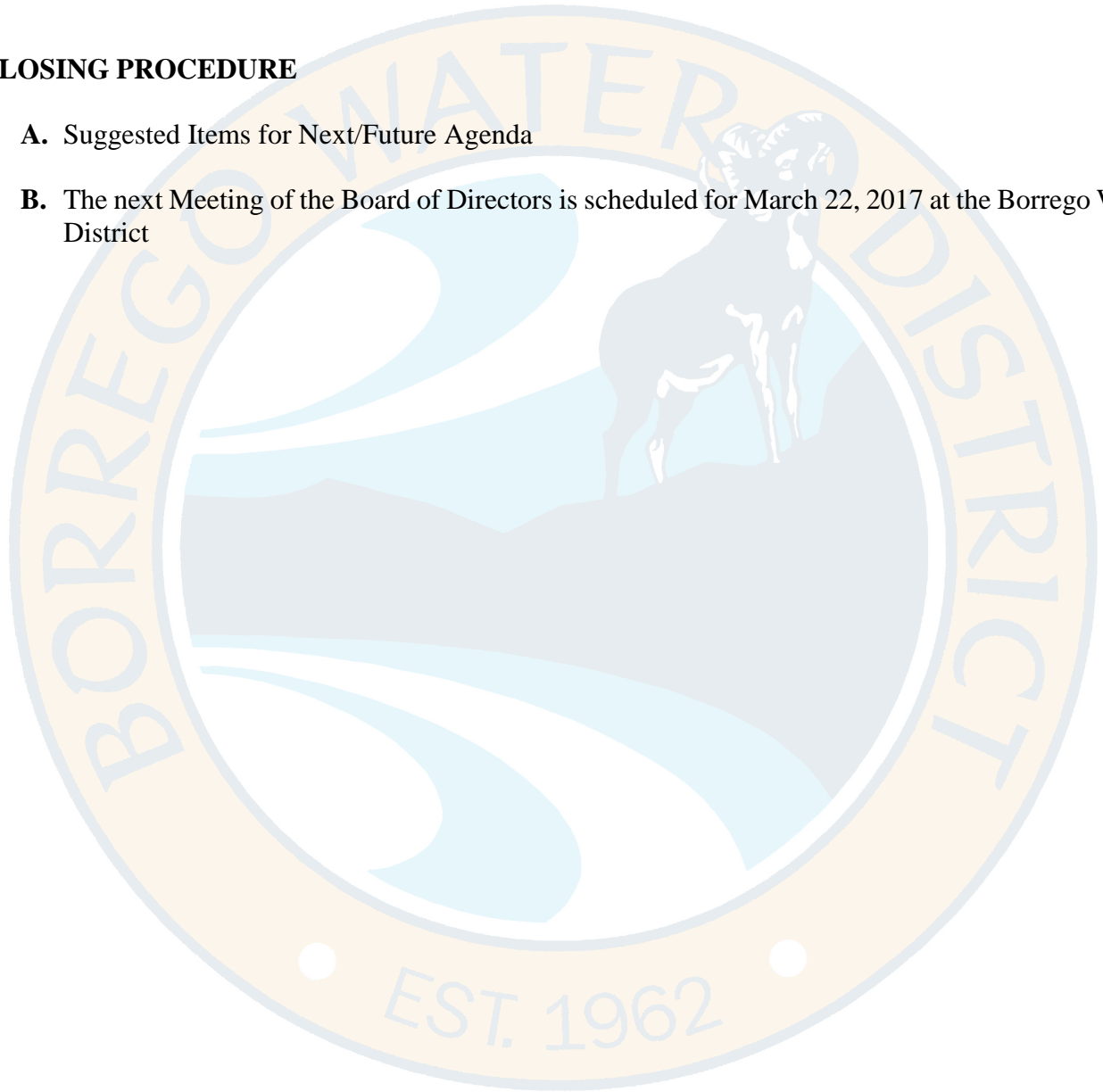

BORREGO WATER DISTRICT  
BOARD OF DIRECTORS MEETING – MARCH 14, 2017  
AGENDA BILL II.A

March 8, 2017

**TO:** Board of Directors, Borrego Water District  
**FROM:** Geoff Poole, General Manager  
**SUBJECT:** Initiation of Proceedings to Consider the Formation of the Borrego Water District Community Facilities District No. 2017-1.

**RECOMMENDED ACTION:**

Discuss and consider approval of the following documents:

1. Settlement Agreement
2. Resolution 2017-03-02 of the Board of Directors of the Borrego Water District Adopting a Map Showing the Boundaries of the Territory Proposed to be Included in Borrego Water District Community Facilities District No. 2017-1
3. Resolution 201-03-03 of the Board of Directors of the Borrego Water District, Declaring its Intention to Establish Borrego Water District Community Facilities District No. 2017-1
4. Resolution 2017-03-04 of the Board of Directors of the Borrego Water District Declaring the Necessity to Incur a Bonded Indebtedness for Community Facilities District No. 2017-1 to be Secured by Special Taxes Levied Therein.

**ITEM DESCRIPTION:**

Directors Brecht, Ehrlich and BWD Staff have been working with Bond Counsel Warren Diven from Best, Best and Krieger as well as Tausig and Associates on the development of the documents necessary to finance the discharge of the remaining obligations on the 2007 CDF Bonds. Bond Counsel Diven has prepared the attached Memorandums to explain the actions as well as drafted the Resolutions. Warren as well as representatives from T2 will be in attendance at the meeting to answer any questions from the Board.

Based on the advice of Bond Counsel, Staff has added a **CLOSED SESSION (IF NEEDED)** to the Agenda in the event an issue is raised that is best discussed in **CLOSED SESSION**. The documents would then be adopted following the **CLOSED SESSION**, if needed, in open session. If there is not a need for **CLOSED SESSION** discussion, it will not be used.

**FISCAL IMPACT:** All obligations for the bond repayment and BWD costs associated with the Bond restructuring and administration are being funded by Rams Hill/T2.

**ATTACHMENTS:**

1. Bond Counsel Memorandum followed by Settlement Agreement
2. Bond Counsel Memorandum followed by Resolutions

Indian Wells  
(760) 568-2611  
Irvine  
(949) 263-2600  
Los Angeles  
(213) 617-8100  
Ontario  
(909) 989-8584



**BEST BEST & KRIEGER**  
**ATTORNEYS AT LAW**

655 West Broadway, 15<sup>th</sup> Floor, San Diego, CA 92101  
Phone: (619) 525-1300 | Fax: (619) 233-6118 | www.bbklaw.com

Riverside  
(951) 686-1450  
Sacramento  
(916) 325-4000  
Walnut Creek  
(925) 977-3300  
Washington, DC  
(202) 785-0600

**Warren B. Diven**  
Partner  
(619) 525-1337  
warren.diven@bbklaw.com

## Memorandum

**To:** President and Board of Directors, Borrego Water District  
**From:** Warren B. Diven  
**Date:** March 9, 2017  
**Re:** Board of Directors Meeting March 14, 2017 Agenda Bill II. \_\_\_ -  
Settlement Agreement • Settlement Agreement by and among T2 Borrego  
LLC, T2 Holding LLC, and Considine Family Foundation on the one hand, and  
Borrego Water District, for itself and on behalf of Community Facilities  
District No. 2007-1 (Montesoro) of the Borrego Water District, on the other  
hand.

### **Background.**

In 2007 the Borrego Water District (“BWD”) undertook proceedings to establish Community Facilities District No. 2007-1 (Montesoro) of the Borrego Water District (CFD No. 2007-1”) for the purpose of refunding certain special tax bonds previously issued by Community Facilities District No. 95-1 of the Borrego Water District (the “CFD No. 95-1 Bonds”), to incur a bonded indebtedness of CFD No. 2007-1 in order to refund the CFD No. 95-1 Bonds and to authorize the levy of special taxes within CFD No. 2007-1 to pay the principal and interest on such indebtedness of CFD No. 2007-1. The authorized electors of CFD No. 2007-1 voted to approve such indebtedness and the levy of such special taxes at an election held on April 25, 2007.

On June 27, 2007, CFD No. 2007-1 issued the \$9,530,000 Community Facilities District No. 2007-1 of Borrego Water District 2007 Special Tax Bonds (the “CFD No. 2007-1 Bonds”). The proceeds of the CFD No. 2007-1 Bonds were used to refund the CFD No. 95-1 Bonds, to pay costs of issuing the CFD No. 2007-1 Bonds and to fund a reserve fund for the CFD No. 95-1 Bonds.

Commencing in the 2009-10 tax year the special taxes on a significant number of the taxable parcels within CFD No. 2007-1 became delinquent for the first time and such delinquencies have continued to the present day. As a consequence these delinquencies the CFD No. 2007-1 Bonds have gone into default and remain in default. Attorneys for BWD brought judicial foreclosure actions against the delinquent parcels and obtained judgements against such delinquent parcels. A Sheriff’s Sale Under Foreclosure was held for a number of the delinquent parcels but the delinquent parcels did not sell.





**BEST BEST & KRIEGER**  
ATTORNEYS AT LAW

The outstanding CFD No. 2007-1 Bonds were subsequently acquired by the Considine Family Foundation and the parcels within CFD No. 2007-1, with the exception of the parcels sold to residential homeowners, have been acquired by T2 Borrego, LLC and T2 Holding LLC, affiliates of the Considine Companies (collectively, the “Property Owners”). The Considine Family Foundation and the Property Owners may be referred to herein collectively as the “Considine Parties.”

In 2016 representatives of Considine Parties approached BWD to discuss the possibility of restructuring the CFD No. 2007-1 Bonds and settling the foreclosure litigation. The Board retained Best Best & Krieger LLP (“BBK”) to act as bond counsel to BWD and CFD No. 2007-1 and authorized BBK and David Taussig & Associates (“DTA”), in its capacity as the Special Tax Consultant to BWD and CFD No. 2007-1, to represent BWD and CFD No. 2007-1 in such discussions with the Considine Parties. Representatives of BBK and DTA entered into discussions with representatives of the Considine Parties and their counsel commencing in June 2016. Throughout the course of these discussions, BBK and DTA have discussed the proposed terms of such a restructuring and settlement with the Bond Committee of the Board of Directors of BWD, the General Manager and the Board of Directors as a whole. Such discussions have reached the point where BBK can recommend that the Board of Directors approve the Settlement Agreement being presented at this meeting of the Board of Directors.

**Summary of Certain Terms of the Settlement Agreement**

The following is a summary of certain provisions contained in the Settlement Agreement.<sup>1</sup>

**Refunding or Discharge of the CFD No. 2007-1 Bonds**

**Refunding of a Portion of the CFD No. 2007-1 Bonds.**

BWD and CFD No. 2007-1 will issue bonds of CFD No. 2007-1 (the “Series 2017A Bonds”) to refund a portion of the CFD No. 2007-1 Bonds. The Series 2017A Bonds will be secured solely by a pledge of the special taxes authorized to be levied pursuant to the existing CFD No. 2007-1 rate and method of apportionment of special taxes (the “CFD No. 2007-1 RMA”) against each of the 66 residential parcels owned by homeowners and 21 residential parcels owned by T2 Borrego LLC (collectively, the “Identified CFD No. 2007-1 Parcels”). **The special taxes to be levied on such residential parcels shall not exceed the special taxes currently authorized to be levied against such residential parcels. No revenues of BWD shall be pledged to the payment of debt service on the Series 2017A Bonds.**

Subject to the limitations described below, the principal amount of the Series 2017A Bonds shall be equal to the maximum principal amount that may be payable from the

---

<sup>1</sup> The summary does not purport to be complete and is qualified in its entirety by reference to the Settlement Agreement.



**BEST BEST & KRIEGER**  
ATTORNEYS AT LAW

aggregate of the special taxes authorized to be levied against the Identified CFD No. 2007-1 Parcels.

The Series 2017A Bonds will be issued as refunding bonds pursuant to the Mello-Roos Community Facilities Act of 1982 (the “Mello-Roos Act”). The Mello-Roos Act places the following limitations on the issuance of the Series 2017A Bonds:

- **The total interest cost to maturity on the Series 2017A Bonds plus the principal amount of the Series 2017A Bonds may not exceed the total interest cost to maturity on CFD No. 2007-1 Bonds to be refunded plus the principal amount of the CFD No. 2007-1 Bonds to be refunded.**
- **The maturity date of the Series 2017A Bonds shall not exceed the maturity date of the CFD No. 2007-1 Bonds, i.e., August 1, 2025.**

The Series 2017A Bonds will be sold by CFD No. 2007-1 to the Considine Family Foundation. CFD No. 2007-1 shall cause the Series 2017A Bonds to be delivered to the Considine Family Foundation in exchange for the CFD No. 2007-1 Bonds to be refunded and such CFD No. 2007-1 Bonds will be discharged and cancelled.

Upon the payment of the Series 2017A Bonds the obligations of the Identified CFD No. 2007-1 Parcels to pay special taxes for CFD No. 2007-1 shall cease to exist.

Defeasance or Discharge of the Remaining Principal Amount of the CFD No. 2007-1 Bonds.

The Board of Directors shall undertake proceedings pursuant to the Mello-Roos Act to establish the Borrego Springs Water District Community Facilities District No. 2017-1 (“CFD No. 2017-1”), to authorize the levy of special taxes within CFD No. 2017-1 and to incur a bonded indebtedness of CFD No. 2017-1 for the purpose of financing the defeasance or discharge of the remainder of the CFD No. 2007-1 Bonds that will not be refunded from the proceeds of the Series 2017A Bonds. The boundaries of CFD No. 2017-1 will include all of the parcels located within the boundaries of CFD No. 2007-1 with the exception of the Identified CFD No. 2007-1 Parcels. **The Identified CFD No. 2007-1 Parcels, i.e., the 66 residential parcels owned by homeowners and the 21 parcels owned by T2 Borrego LLC, will not be subject to the levy of special taxes by CFD No. 2017-1.**

Upon the establishment of CFD No. 2017-1, CFD No. 2017-1 shall issue bonds secured solely by the levy of special taxes within CFD No. 2017-1 (the “Series 2017B Bonds”) for the purpose of discharging the remaining CFD No. 2007-1 Bonds. **No revenues of BWD shall be pledged to the payment of debt service on the Series 2017B Bonds.**



**BEST BEST & KRIEGER**  
ATTORNEYS AT LAW

Waiver of Payment of CFD No. 2007-1 Special Taxes

The Considine Family Foundation, BWD and CFD No. 2007-1 will irrevocably waive and discharge the payment by Property Owners of the delinquent CFD No. 2007-1 special taxes and all penalties, interest and other accrued charges.

Waiver of Interest Owed on the CFD 2007-1 Bonds.

The Considine Family Foundation will irrevocably waive and discharge the right to received certain accrued and unpaid interest and principal payments on the CFD No. 2007-1 Bonds.

Dismissal of the Foreclosure Litigation.

As soon as practicable following the closing of the Series 2017A Bonds and the Series 2017B Bonds, BWD shall dismiss the foreclosure litigation.

Costs of Issuance for the Series 2017A Bonds and Series 2017B Bonds.

The Property Owners shall, as a condition precedent to the closing the Series 2017A Bonds and the Series 2017B Bonds, pay all outstanding costs of issuing such bonds, including, but not limited to, the fees of BBK and DTA.

We would welcome any questions from the Board regarding the proposed Settlement Agreement.

cc: Geoff Poole, General Manager

## SETTLEMENT AGREEMENT

This SETTLEMENT AGREEMENT ("Agreement") is made and entered into as of March 14, 2017, by and among T2 Borrego LLC, a Colorado limited liability company ("Borrego"), T2 Holding LLC, a Colorado limited liability company ("Holding," and together with Borrego, "Property Owner") and Considine Family Foundation, a Colorado nonprofit corporation ("Bond Owner," and together with Borrego and Holding, the "Considine Parties") on the one hand, and Borrego Water District, a water district organized and existing under Division 13 of the Water Code of the State of California, for itself ("BWD") and on behalf of Community Facilities District No. 2007-1 (Montesoro) of Borrego Water District ("CFD 2007-1," and together with BWD, "BWD Parties"), on the other hand, in relation to the matters set forth below. For purposes of this Agreement, Borrego, Holding, Bond Owner, BWD and CFD 2007-1 shall be referred to herein individually as a "Party" and collectively as the "Parties."

### RECITALS

A. CFD 2007-1 includes approximately 3,140 gross acres of property in a master-planned community now known as "Rams Hill" located in the unincorporated community of Borrego Springs, San Diego County, California.

B. Property Owner is the owner of that certain real property within CFD 2007-1, including residential and commercial zoned parcels and parcels that comprise an 18-hole golf course, club house, and maintenance facility. Attached as Exhibit A is the list of legal parcels owned by Property Owner.

C. Persons unrelated to Property Owner ("Unrelated Owners") collectively own 66 residential parcels within CFD 2007-1. Attached as Exhibit B is the list of legal parcels owned by Unrelated Owners.

D. Bond Owner, a related party to Property Owner, owns 100% of the issued and outstanding \$9,320,000 aggregate principal amount of the Community Facilities District No. 2007-1 (Montesoro) of Borrego Water District 2007 Special Tax Bonds ("CFD 2007-1 Bonds"). The CFD 2007-1 Bonds are further described as term bonds subject to mandatory sinking fund redemption with outstanding principal balances as of the date hereof as follows: \$5,060,000 bearing interest at 5.75% per annum, maturing August 1, 2025, and identified by CUSIP No. 100027AT8; \$4,260,000 bearing interest at 5.75% per annum, maturing August 1, 2032, and identified by CUSIP No. 100027BA8.

E. The CFD 2007-1 Bonds were authorized by and issued pursuant to the Mello-Roos Community Facilities Act of 1982, as amended, commencing at Section 53311, *et seq.*, of the California Government Code ("Act"), Borrego Water District's Resolution No. 2007-5-1, adopted by the Board of Directors ("Board") of BWD on May 23, 2007, and a Bond Indenture dated as of June 1, 2007, by and between CFD 2007-1 and U.S. Bank National Association, as Trustee ("Trustee"), as amended by Amendment No. 1 to Bond Indenture dated as of October 1, 2010, by and between CFD 2007-1 and the Trustee, and as further amended by Amendment

No. 2 to Bond Indenture dated as of November 1, 2010, by and between CFD 2007-1 and the Trustee (as amended, "CFD 2007-1 Bond Indenture").

F. The CFD 2007-1 Bonds are secured by a pledge of Special Taxes as such term is defined in the "Amended and Restated Rate and Method of Apportionment of Special Tax for Community Facilities District No. 2007-1 (Montesoro) Borrego Water District" ("CFD 2007-1 RMA") attached to the Notice of Special Tax Lien for CFD 2007-1 ("CFD 2007-1 Special Tax Lien") that was recorded in the office of the County Recorder of the County of San Diego on May 2, 2007, as Document No. 2007-0300206.

G. The CFD 2007-1 Bonds are in default. As of February 2, 2017, \$12,816,116 was owed under the CFD 2007-1 Bonds, representing principal in the amount of \$9,320,000 (of which \$1,535,000 is past due) and accrued and unpaid interest in the amount of \$3,496,116 ("CFD 2007-1 Bond Default").

H. Special Taxes are delinquent ("Delinquent Special Taxes") with respect to the taxable parcels owned by Property Owner within CFD 2007-1 as identified on Exhibit A hereto. As of February 1, 2017, Delinquent Special Taxes with accrued penalties, interest and other charges aggregated \$33,606,848 with respect to the taxable parcels owned by Property Owner.

I. BWD Parties commenced foreclosure litigation against Property Owner with respect to the Delinquent Special Taxes ("Foreclosure Litigation").

J. The Parties believe that resolving the CFD 2007-1 Bond Default, settling the Foreclosure Litigation and remedying the Delinquent Special Taxes is in the best interest of the Parties, the Rams Hill community and the community at large.

K. It is the intent of the Parties, therefore, to resolve the CFD 2007-1 Bond Default, to settle the Foreclosure Litigation, and to remedy the Delinquent Special Taxes by agreeing to and implementing the terms and conditions set forth in this Agreement.

NOW, THEREFORE, in consideration of the above Recitals and for other good and valuable consideration, the receipt and sufficiency of which are hereby acknowledged, the Parties agree as follows:

### **AGREEMENT**

1. Amendment of CFD 2007-1 Bond Indenture. In order to implement the terms set for herein below in paragraphs 2 and 3, it is necessary that the CFD 2007-1 Bond Indenture be modified as provided for in Amendment No. 3 to Bond Indenture ("Amendment No. 3"), a copy of which is attached as Exhibit C hereto and incorporated herein by this reference. Amendment No. 3 shall amend the CFD 2007-1 Bond Indenture to (a) authorize the optional redemption of CFD 2007-1 Bonds on any date after March 1, 2017, rather than on each Interest Payment Date from August 1, 2017, and (b) reduce the redemption price for any optional redemption from 102% of the principal amount of the CFD 2007-1 Bonds to be redeemed to 100% of such principal amount. By approving this Agreement, the Parties hereto agree to the terms and conditions set forth in Amendment No. 3 and the Bond Owner further agrees to execute and deliver consent to Amendment No. 3 as is required pursuant to Section 6.2 of the CFD 2007-1

Bond Indenture. Amendment No. 3 shall be immediately effective upon approval and execution of this Agreement by the Board of BWD and the other Parties.

2. The Series 2017A Bonds.

(a) Issuance of the Series 2017A Bonds. BWD shall take the actions necessary and appropriate under the Act, this Agreement, the terms and conditions set forth in a Fiscal Agent Agreement ("Series 2017A Bonds Fiscal Agent Agreement") by and between CFD 2007-1 and U.S. Bank, as fiscal agent ("Series 2017A Fiscal Agent") and a resolution of the Board of BWD, acting for and on behalf of CFD 2007-1, to issue the Community Facilities District No. 2007-1 (Montesoro) of the Borrego Water District Special Tax Refunding Bonds, Series 2017A ("Series 2017A Bonds") for the purpose of defeasing and refunding a portion of the outstanding CFD 2007-1 Bonds determined pursuant to paragraph 2.c(i) below.

(b) Security for the Series 2017A Bonds. The Series 2017A Bonds shall be secured solely by a pledge of the Net Special Taxes that are authorized to be levied pursuant to the CFD 2007-1 RMA against each of the 87 Assessor's Parcels designated as Residential Property under the CFD 2007-1 RMA and identified in Exhibit D hereto and incorporated herein by this reference ("Identified CFD 2007-1 Parcels"). Sixty-six of the Identified CFD 2007-1 Parcels are owned by Unrelated Owners and 21 of such parcels are owned by Borrego. "Net Special Taxes" shall mean the Assigned Special Taxes (as such term is defined in the CFD 2007-1 RMA) authorized to be levied on the Identified CFD 2007-1 Parcels each Fiscal Year (as such term shall be defined in the CFD 2007-1 RMA) minus the amount of such Special Taxes equal to the Administrative Expense Cap (as such term shall be defined in the Series 2017A Bonds Fiscal Agent Agreement) set aside to pay Administrative Expenses (as such term shall be defined in the Series 2017A Bonds Fiscal Agent Agreement).

(c) Terms of the Series 2017A Bonds.

(i) *Principal Amount of the Series 2017A Bonds.* The principal amount of the Series 2017A Bonds shall be equal to the maximum principal amount that may be payable from the aggregate of Net Special Taxes authorized to be levied annually on the Identified CFD 2007-1 Parcels through the Series 2017A Bonds Maturity Date (as defined below) of the Series 2017A Bonds.

(ii) *Term Bonds and Maturity Schedule.* The Series 2017A Bonds shall be issued as term bonds maturing on or after August 1, 2025 ("Series 2017A Bonds Maturity Date"), and bearing interest at the market rate at the time of the Closing (as defined below). The Series 2017A Bonds shall be amortized throughout the term thereof in accordance with the amortization table set forth in the Series 2017A Bonds Fiscal Agent Agreement.

(iii) *Reserve Requirement and Reserve Fund.* The Series 2017A Bonds Fiscal Agent Agreement shall provide that the reserve requirement for the Series 2017A Bonds shall be zero as long as Bond Owner (or related party) owns the Series 2017A Bonds; otherwise the Reserve Requirement shall be an amount equal to 10% of the outstanding Series 2017A Bonds as of the date of calculation by BWD ("Series 2017A Bonds Reserve Requirement"). The Series 2017A Bonds Fiscal Agent Agreement shall provide for the establishment of a reserve



fund ("Series 2017A Bonds Reserve Fund") which shall be unfunded so long as the Series 2017A Bonds are owned by the Bond Owner (or related party). As a condition precedent to the sale and transfer of the Series 2017A Bonds, in whole or in part, to an unrelated third party, the Series 2017A Bonds Reserve Fund shall be funded by the Considine Parties in an amount equal to the Series 2017A Bonds Reserve Requirement computed as of the date of the such and transfer.

(iv) *Judicial Foreclosure.* The Series 2017A Bonds Fiscal Agent Agreement shall provide that the Board of BWD, acting in its capacity as the legislative body of CFD 2007-1, shall covenant to order the collection of delinquent Special Taxes levied on any Identified CFD 2007-1 Parcels owned by an Unrelated Owner by an action brought in the California Superior Court to foreclose the Special Tax lien pursuant to terms substantially equivalent to the covenant set forth in the CFD 2007-1 Bond Indenture.

(v) *Final Terms and Conditions of the Series 2017A Bonds.* The final terms and conditions of the Series 2017A Bonds and the terms of the 2017A Fiscal Agent Agreement shall be subject to the express written approval of the Parties, which shall be in a form of a certificate delivered at the Closing of the Series 2017A Bonds.

(d) Consideration for the Sale of the Series 2017A Bonds. As consideration for the sale of the Series 2017A Bonds by CFD 2007-1 to the Bond Owner, the Bond Owner shall assign and transfer to CFD 2007-1 the ownership of that principal amount of the CFD 2007-1 Bonds equal to the principal amount of the Series 2017A Bonds and shall waive and forever discharge the right to receive any scheduled debt service payments, including interest, that had accrued on the 2007-1 Bonds through the Closing (as defined below).

(e) Determination of the Special Tax Requirement for CFD 2007-1. The Parties agree that provided the Bond Owner (or related party) owns the Series 2017A Bonds the yearly determination of the Special Tax Requirement (as such term is defined in the CFD 2007-1 RMA) shall exclude (i) any replenishment, or levy for replenishment of, the Reserve Fund relating to the Series 2017A Bonds, and (ii) a payment for reasonably anticipated delinquent Special Taxes based on the delinquency rate for the Special Taxes levied in the previous fiscal year.

### 3. CFD 2017-1.

(a) Overlay CFD. BWD shall take the actions necessary and appropriate under the Act to establish and form the Borrego Water District Community Facilities District No. 2017-1 ("CFD 2017-1") for the purpose of defeasing the obligation to pay that portion of the principal amount of the CFD 2007-1 Bonds secured by the Special Taxes authorized to be levied by the CFD 2007-1 RMA that will not otherwise be defeased and refunded from the proceeds of the Series 2017A Bonds or otherwise waived and discharged pursuant to paragraph 5 below ("Remaining Outstanding CFD 2007-1 Bonds"). The boundary map for CFD 2017-1 comprised of the assessor parcels identified therein is attached hereto as Exhibit E ("CFD 2017-1 Boundary Map"). Property Owner shall not protest the formation of CFD 2017-1, the levy of CFD 2017-1 Special Taxes (defined below) within CFD 2017-1 or the issuance of bonds secured by such CFD 2017-1 Special Taxes and agrees to cast its ballot in favor of the levy of the CFD 2017-1

Special Taxes within CFD 2017-1, the issuance of bonds of CFD 2017-1 and the establishment of an appropriations limit for CFD 2017-1.

(b) CFD 2017-1 RMA. The Rate and Method of Apportionment for Borrego Water District Community Facilities District No. 2017-1 ("CFD 2017-1 RMA") in the form attached hereto as Exhibit F shall be used in connection with CFD 2017-1 formation proceedings.

(c) Series 2017B Bonds. BWD shall take the actions necessary and appropriate under the Act and this Agreement to issue the Community Facilities District No. 2007-1 of the Borrego Water District Special Tax Refunding Bonds, Series 2017B ("Series 2017B Bonds") pursuant to a resolution of the Board of BWD, acting for and on behalf of CFD 2017-1, the terms and conditions set forth in this Agreement, and a Fiscal Agent Agreement ("Series 2017B Bonds Fiscal Agent Agreement") by and between CFD 2017-1 and U.S. Bank, as fiscal agent ("Series 2017B Bonds Fiscal Agent"), for the purpose of defeasing the Remaining Outstanding CFD 2007-1 Bonds.

(d) Security for the Series 2017B Bonds. The Series 2017B Bonds shall be secured solely by a pledge of the Net Special Taxes that are authorized to be levied pursuant to the CFD 2017-1 RMA against the Assessor's Parcels designated under the CFD 2017-1 RMA and identified in the CFD 2017-1 Boundary Map. For as long as the Series 2017B Bonds are owned by the Bond Owner, BWD shall hand bill the CFD 2017-1 Special Taxes.

(e) Terms of Series 2017B Bonds.

(i) *Principal Amount of 2017B Bonds*. The principal amount of the Series 2017B Bonds shall be equal to that amount that shall be necessary to defease and discharge the Remaining Outstanding CFD 2007-1 Bonds.

(ii) *Term Bonds and Maturity Schedule*. The Series 2017B Bonds shall be issued as term bonds, in one or more series, each maturing on a date mutually agreed to by the Parties ("Series 2017B Bonds Maturity Date") and bearing interest at the market rate at the time of the Closing (as defined below). The Series 2017B Bonds shall be amortized throughout the terms thereof in accordance with the amortization table(s) set forth in the Series 2017B Bonds Fiscal Agent Agreement. The first interest payment date shall be February 1, 2018.

(iii) *Reserve Requirement and Reserve Fund*. The Series 2017B Bonds Fiscal Agent Agreement shall provide that the reserve requirement for the Series 2017B Bonds shall be zero as long as Bond Owner (or related party) owns the Series 2017B Bonds; otherwise the Reserve Requirement shall be an amount equal to 10% of the outstanding Series 2017B Bonds as of the date of the calculation by BWD ("Series 2017B Bonds Reserve Requirement"). The Series 2017B Bonds Fiscal Agent Agreement shall provide for the establishment of a reserve fund ("Series 2017B Bonds Reserve Fund") which shall be unfunded so long as the Series 2017B Bonds are owned by the Bond Owner (or related party). As a condition precedent to the sale and transfer of the Series 2017B Bonds, in whole or in part, to an unrelated third party, the Series 2017B Bonds Reserve Fund shall be funded by the Considine Parties in an amount equal

to the Series 2017B Bonds Reserve Requirement computed as of the date of such sale and transfer of the Series 2017B Bonds.

(iv) Additional Terms. In addition to customary and ordinary terms, the Series 2017B Bonds Fiscal Agent Agreement shall include the following provisions which shall apply only if the Series 2017B Bonds are owned by the Bond Owner (or a related party): (i) the BWD Parties shall not be required to enforce the special tax lien for delinquent CFD 2017-1 Special Taxes related to Property Owner, (ii) in lieu of payment of CFD 2017-1 Special Taxes by Property Owner, Property Owner shall be allowed to tender Series 2017B Bonds to the Series 2017B Fiscal Agent in a principal amount equal to CFD 2017-1 Special Taxes due and such Series 2017B Bonds shall be cancelled and forever discharged, and (iii) if there is any default by Property Owner in the payment of CFD 2017-1 Special Taxes levied on the property within CFD 2017-1, Series 2017B Bonds in a principal amount equal to such delinquent CFD 2017-1 Special Taxes shall be deemed tendered to the Series 2017B Fiscal Agent and such Series 2017B Bonds so deemed tendered shall be cancelled and forever discharged.

(f) Further Change Proceedings. The Parties acknowledge or are acknowledging that CFD 2017-1 and the CFD 2017-1 RMA may need to be further amended or replaced, and, therefore, upon request of the Property Owner and Bond Owner, BWD shall conduct change proceedings with respect to CFD 2017-1 (including, but not limited to, amending CFD 2017-1 RMA) in accordance with the Act. Such changes shall be subject to the mutual agreement of the Parties.

4. Waiver of Payment of Special Taxes. Bond Owner and BWD Parties hereby irrevocably waive and forever discharge the payment by Property Owner, predecessors or successors, of the Delinquent Special Taxes and all penalties, interest, costs and other charges accrued thereon, through the date of the Closing with respect to Special Taxes that were levied in any prior fiscal year against the parcels identified on Exhibit A hereto.

5. Waiver of Interest Owed on the CFD 2007-1 Bonds. Bond Owner hereby irrevocably waives and forever discharges the right to receive any accrued and unpaid interest, and principal payments with respect to the CFD 2007-1 Bonds as of the Closing in excess of the sum of the Series 2017A Bonds, the Series 2017B Bonds and Interest Paid at Closing (as defined in paragraph 10 below).

6. Cancellation of the CFD 2007-1 Bond Indenture. In connection with the Closing, the Parties shall execute and deliver the requisite documents cancelling the CFD 2007-1 Bond Indenture.

7. Closing. The closing of the transactions contemplated herein (“Closing”), including the issuance of the Series 2017A Bonds and the Series 2017B Bonds shall occur as soon as practicable after the Board of the BWD approves the issuance of the Series 2017A Bonds and Series 2017B Bonds.

8. Dismissal of Foreclosure Litigation. As soon as practicable after the Closing, BWD shall dismiss the Foreclosure Litigation and record Releases of Judgment, to the extent necessary.

9. Costs of Issuance for the Series 2017A and 2017B Bonds. To the extent not previously paid by the Property Owner, the Property Owner shall, as a condition precedent to the closing of the Series 2017A and 2017B Bonds, pay all outstanding costs of issuing such bonds including, but not limited to, the fees of bond counsel, the Fiscal Agent and David Taussig & Associates, as the special tax consultant to CFD 2007-1 and CFD 2017-1 (collectively, "Outstanding Transaction Costs").

10. Funds in Accounts Established Under the 2007-1 Indenture at Time of Closing. At the option of the Considine Parties, the funds on deposit in the accounts held by the Trustee pursuant to the CFD 2007-1 Indenture as of the date of the Closing can be used to pay the Outstanding Transaction Costs or the accrued but unpaid interest on the CFD 2007-1 Bonds ("Interest Paid at Closing").

11. Effective Date. This Agreement shall be effective and binding only when a counterpart hereof has been executed and delivered by each Party, the Board resolution approving this Agreement has become effective.

12. Representations and Warranties. Each of the Parties makes the representations and warranties set forth below to and for the benefit of each other Party:

(a) Formation and Good Standing. The Party is duly organized, validly existing and in good standing under the laws of its formation, with organizational power and legal authority to own its properties and assets and to carry on its business.

(b) Due Authorization. This Agreement and the agreements to be executed in connection herewith, have been duly authorized, executed and delivered by the Party.

(c) Enforceability. This Agreement and the agreements to be executed in connection herewith constitute and, when duly executed and delivered by the other Parties, will constitute the legally valid and binding obligations of the Party, enforceable against the Party in accordance with their terms.

13. Exhibits; Entire Agreement; Modification. All recitals at the beginning of this Agreement and all exhibits attached and referred to in this Agreement are hereby incorporated herein as if fully set forth in (and shall be deemed to be a part of) this Agreement. This Agreement contains the entire agreement between the Parties respecting the matters herein set forth and supersede all prior agreements and termsheets between the Parties respecting such matters. This Agreement may not be modified or amended except by written agreement signed by the Parties.

14. Interpretation. Section headings shall not be used in construing this Agreement. Each Party acknowledges that such Party and its counsel, after negotiation and consultation, have reviewed and revised this Agreement. As such, the terms of this Agreement shall be fairly construed and the usual rule of construction, to the effect that any ambiguities herein should be

resolved against the drafting party, shall not be employed in the interpretation of this Agreement or any amendments, modifications or exhibits hereto or thereto. The words "herein," "hereof," "hereunder," "hereby," "this Agreement" and other similar references shall be construed to mean and include this Agreement and all amendments and supplements hereto unless the context shall clearly indicate or require otherwise. Whenever the words "including," "include" or "includes" are used in this Agreement, they shall be interpreted in a nonexclusive manner.

15. Governing Law. This Agreement shall be construed and enforced in accordance with the laws of California (without regard to conflicts of laws).

16. Successors and Assigns. This Agreement and the terms and provisions hereof shall inure to the benefit of and be binding upon the successors and assigns of the Parties.

17. Notices. Any notice which a Party is required or may desire to give another Party shall be in writing and may be delivered (a) personally, (b) by United States registered or certified mail, postage prepaid, (c) by Federal Express or other reputable courier service regularly providing evidence of delivery (with charges paid by the Party sending the notice), or (d) by PDF or similar attachment to an email, provided that such email attachment shall be followed within one (1) business day by delivery of such notice pursuant to clause (a), (b) or (c) above. Any such notice to a Party shall be addressed at the address set forth below (subject to the right of a Party to designate a different address for itself by notice similarly given). Service of any such notice or other communications so made shall be deemed effective on the day of actual delivery (whether accepted or refused) as evidenced by printed confirmation if by email attachment (provided that if any notice or other communication to be delivered by email attachment as provided above cannot be transmitted because of a problem affecting the receiving Party's computer, the deadline for receiving such notice or other communication shall be extended through the next business day), as shown by the addressee's return receipt if by certified mail, and as confirmed by the courier service if by courier; provided, however, that if such actual delivery occurs after 5:00 p.m. (local time where received) or on a non-business day, then such notice or communication so made shall be deemed effective on the first business day after the day of actual delivery. Except as expressly provided above and in Section 20 with respect to certain email attachments, no communications via electronic mail shall be effective to give any notice, request, direction, demand, consent, waiver, approval or other communications hereunder.

**TO CONSIDINE PARTIES:**

Considine Companies  
4582 S. Ulster Street Parkway, Suite 410  
Denver, Colorado 80237  
Attention: Becky Holeman  
Telephone: (720) 200-1388  
Email: bholeman@considinecos.com

With Copies to:

Allen Matkins Leck Gamble Mallory & Natsis LLP  
501 West Broadway, 15th Floor  
San Diego, California 92101  
Attention: Debra A. Riley, Esq.  
Telephone: (619) 235-1520  
E-mail: driley@allenmatkins.com

**TO BWD PARTIES:**

Borrego Water District  
806 Palm Canyon Drive  
Borrego Springs, California 92004  
Attn: General Manager  
Telephone: (760) 767-5806  
Email: geoff@borregowd.org

With Copies to:

Best Best & Krieger LLP  
655 West Broadway, 15th Floor  
San Diego, California 92101  
Attention: Warren B. Diven, Esq.  
Telephone: (619) 525-1337  
E-mail: warren.diven@bbklaw.com

18. Third Parties. Nothing in this Agreement, whether expressed or implied, is intended to confer any rights or remedies under or by reason of this Agreement on any other person other than the Parties, and their respective successors and assigns, nor is anything in this Agreement intended to relieve or discharge the obligation or liability of any third persons to any Party, nor shall any provision give any third parties any right of subrogation or action over or against any Party.

19. Legal Costs. If any Party or Parties bring(s) any suit or other proceeding, including an arbitration proceeding, with respect to the subject matter or the enforcement of this Agreement, the prevailing Party or Parties, as the case may be (as determined by the court, agency, arbitrator or other authority before which such suit or proceeding is commenced), in addition to such other relief as may be awarded, shall be entitled to recover its reasonable fees, expenses and costs actually incurred from the non-prevailing Party(ies).

20. Counterparts; Delivery. This Agreement may be executed in one or more counterparts, each of which shall be deemed an original, but all of which shall constitute one and the same document. The delivery of an executed counterpart of this Agreement by PDF or similar attachment to an email shall constitute effective delivery of such counterpart for all purposes with the same force and effect as the delivery of an original, executed counterpart.

21. Further Assurances. Each Party shall, from time to time, execute, acknowledge where appropriate and deliver, such further instruments and documents, and take such other



action, as any other Party may reasonably request in order to carry out the intent and purpose of this Agreement or of any of the documents executed in connection herewith, at the expense of the Party making such request (provided such instruments, documents and actions do not increase in any material respect the costs to, or liability or obligations of, the Party receiving such a request in a manner not otherwise provided for herein).

22. Severability. If any portion of this Agreement shall become illegal, null or void or against public policy, for any reason, or shall be held by any court of competent jurisdiction to be illegal, null or void or against public policy, the remaining portion of this Agreement shall not be affected thereby and shall remain in full force and effect to the fullest extent permissible by law.

**[SIGNATURES ON FOLLOWING PAGE]**

IN ORDER TO EVIDENCE THEIR AGREEMENT TO THE FOREGOING, the Parties have executed this Agreement as of the date first above written.

**CONSIDINE PARTIES:**

T2 BORREGO, LLC,  
a Colorado limited liability company

By: \_\_\_\_\_  
Terry Considine, Manager

T2 HOLDING, LLC,  
a Colorado limited liability company

By: \_\_\_\_\_  
Terry Considine, Manager

CONSIDINE FAMILY FOUNDATION,  
a Colorado nonprofit corporation

By: \_\_\_\_\_  
Terry Considine, Vice-President

**BWD PARTIES:**

BORREGO WATER DISTRICT, for and on behalf of  
itself and Community Facilities District No. 2007-1  
(Montesoro) of Borrego Water District

By: \_\_\_\_\_  
General Manager

**ATTEST:**

\_\_\_\_\_  
District Secretary

**APPROVED AS TO FORM:**

\_\_\_\_\_  
Best Best & Krieger LLP

**EXHIBIT A**

**LIST OF LEGAL PARCELS OWNED BY PROPERTY OWNER**

2001203900	2002812000	2003405300	2003601700	2003800100
2001204100	2002812600	2003405400	2003601800	2003800200
2001204800	2002813400	2003405500	2003700300	2003800300
2001205100	2002830600	2003405600	2003700400	2003800400
2001205200	2002830700	2003405700	2003700500	2003800500
2001205300	2002830800	2003405800	2003700600	2003800600
2001401200	2003111800	2003405900	2003700700	2003800700
2001603000	2003113700	2003406000	2003700800	2003800800
2002102200	2003114300	2003406100	2003700900	2003800900
2002710300	2003114400	2003406200	2003701000	2003801000
2002710400	2003114500	2003406300	2003701100	2003801100
2002710600	2003114600	2003406400	2003701200	2003801200
2002710700	2003123200	2003406500	2003701300	2003801300
2002711500	2003123300	2003406600	2003701400	2003801400
2002711600	2003123400	2003406700	2003701500	2003801500
2002712100	2003123500	2003406800	2003701600	2003801600
2002712200	2003123600	2003406900	2003701700	2003801700
2002712300	2003302300	2003407000	2003701800	2003801800
2002712400	2003302400	2003407100	2003701900	2003801900
2002712900	2003302700	2003407200	2003702000	2003802000
2002713400	2003302800	2003407300	2003702100	2003802100
2002713700	2003302900	2003407400	2003702200	2003802200
2002720800	2003303300	2003407500	2003702300	2003802300
2002730200	2003303400	2003407900	2003702400	2003802400
2002730300	2003305100	2003408000	2003702500	2003802500
2002730400	2003307600	2003408100	2003702600	2003802600
2002730600	2003307700	2003408200	2003702700	2003802700
2002730700	2003307800	2003408300	2003702800	2003802800
2002730800	2003307900	2003408400	2003702900	2003900100
2002740200	2003308000	2003408500	2003703000	2003900200
2002750800	2003308100	2003408600	2003703100	2003900300
2002750900	2003400100	2003408700	2003703200	2003900400
2002751000	2003400400	2003408800	2003703300	2003900500
2002751100	2003400500	2003408900	2003703400	2003900600
2002811000	2003400600	2003409000	2003703500	2003900700
2002811400	2003400700	2003500100	2003703600	2003900800
2002811500	2003402300	2003502400	2003703800	2003900900

2003901000	2003904500	2004005100	2004013200
2003901100	2003904600	2004005200	2004013300
2003901200	2004000100	2004005300	2004013400
2003901300	2004001100	2004005400	2004013600
2003901400	2004001200	2004005500	2004013700
2003901500	2004001300	2004005600	2004013800
2003901600	2004001500	2004010100	2004013900
2003901700	2004001600	2004010200	2004014000
2003901800	2004001700	2004010400	2004014100
2003901900	2004001800	2004010500	2004014200
2003902000	2004001900	2004010600	2004014400
2003902100	2004002000	2004010800	2004014600
2003902200	2004002100	2004010900	2004014700
2003902300	2004002200	2004011000	2004014800
2003902400	2004002300	2004011100	2004015000
2003902500	2004002400	2004011200	2004015100
2003902600	2004002900	2004011300	2004015600
2003902700	2004003200	2004011400	2004015700
2003902800	2004003300	2004011500	2004015800
2003902900	2004003400	2004011600	2004015900
2003903000	2004003500	2004011700	2004016000
2003903100	2004003600	2004011800	2004016100
2003903200	2004003700	2004011900	2004016200
2003903300	2004003800	2004012000	2004016300
2003903400	2004003900	2004012100	2004016400
2003903500	2004004000	2004012200	
2003903600	2004004100	2004012300	
2003903700	2004004200	2004012400	
2003903800	2004004300	2004012500	
2003903900	2004004400	2004012600	
2003904000	2004004500	2004012700	
2003904100	2004004600	2004012800	
2003904200	2004004700	2004012900	
2003904300	2004004800	2004013000	
2003904400	2004004900	2004013100	

**NUMBER OF PARCELS: 315**

**EXHIBIT B**

**LIST OF LEGAL PARCELS OWNED BY UNRELATED OWNERS**

2003113800	2003504700	2003600500
2003407600	2003504800	2003600600
2003407700	2003504900	2003600700
2003407800	2003505000	2003600800
2003501300	2003505100	2003600900
2003501500	2003505200	2003601000
2003501600	2003505300	2003601100
2003501700	2003505400	2003601200
2003501800	2003505500	2003601300
2003501900	2003505600	2003601400
2003502000	2003505800	2003601500
2003502100	2003505900	2003601600
2003502200	2003506200	2004002600
2003502500	2003506300	2004003000
2003502700	2003506400	2004003100
2003502800	2003506500	2004006000
2003502900	2003506600	2004006100
2003503100	2003506700	2004010300
2003504300	2003600100	2004014500
2003504400	2003600200	2004015500
2003504500	2003600300	2004016900
2003504600	2003600400	2004017000

**Number of Parcels 66**

**EXHIBIT C**

**AMENDMENT NO. 3 TO CFD 2007-1 BOND INDENTURE**



---

---

**AMENDMENT NO. 3 TO BOND INDENTURE**

Between

**COMMUNITY FACILITIES DISTRICT NO. 2007-1  
(MONTESORO) OF THE  
BORREGO WATER DISTRICT**

and

**U.S. BANK NATIONAL ASSOCIATION,  
as Trustee**

**\$9,530,000  
BORREGO WATER DISTRICT  
COMMUNITY FACILITIES DISTRICT NO. 2007-1  
(MONTESORO)  
SERIES 2007 SPECIAL TAX BONDS**

**Dated as of \_\_\_\_\_ 1, 2017**

---

---

## AMENDMENT NO. 3 TO BOND INDENTURE

THIS AMENDMENT NO. 3 TO BOND INDENTURE, dated as of \_\_\_\_\_ 1, 2017 (“**Amendment No. 3**”), is made and entered into by Community Facilities District No. 2007-1 (Montesoro) of the Borrego Water District (the “**District**”) and the U.S. Bank National Association (“**Trustee**”), as Trustee.

### RECITALS:

WHEREAS, the District, pursuant to the terms and provisions of the Mello-Roos Community Facilities Act of 1982, as amended, being Chapter 2.5, Part 1, Division 2, Title 5, of the Government Code of the State of California (the “**Act**”) and that certain Bond Indenture, dated as of June 1, 2007 (the “**Original Indenture**”), by and between the Trustee and the District, previously issued its \$9,530,000 Borrego Water District Community Facilities District No. 2007-1 (Montesoro) Series 2007 Special Tax Bonds (the “**Series 2007 Bonds**”); and

WHEREAS, with the written consent of Nuveen Investments (the “**Prior Bondowner**”), the District entered into that certain Amendment No. 1 to Bond Indenture, dated as of October 1, 2010 (the “**Amendment No. 1**”), with the Trustee, which, among other things, (i) allowed for the appointment of a receiver in the event of Special Tax delinquencies, (ii) required the consent of 100% of the Bondowners in order to credit bid at a foreclosure sale of delinquent parcels within the District, and (iii) allowed for the tender of the Series 2007 Bonds within the District; and

WHEREAS, with the written consent of the Prior Bondowner, the District entered into that certain Amendment No. 2 to Bond Indenture, dated as of November 1, 2010 (the “**Amendment No. 2**”) and, together with the Original Indenture and Amendment No. 1, the “**Indenture**”), with the Trustee, which, among other things allowed the Trustee to transfer moneys deposited in the Reserve Account (as defined in the Indenture) to the Administrative Expense Account and to increase the Administrative Expense Cap to an amount greater than \$60,000 upon the written direction of the District; and

WHEREAS, the Series 2007 Bonds are currently in default. As of February 2, 2017, \$12,816,116 was owed under the Series 2007 Bonds, representing principal in the amount of \$9,320,000 (of which \$1,535,000 is past due) and accrued and unpaid interest in the amount of \$3,496,116 (the “**Bond Default**”); and

WHEREAS, since the date of issuance of the Series 2007 Bonds, certain parcels of property within the District have become delinquent in the payment of Special Taxes, and the District has commenced foreclosure litigation with respect to such parcels (the “**Foreclosure Litigation**”); and

WHEREAS, Considine Family Foundation, a Colorado nonprofit corporation, is currently the 100% owner of the Series 2007 Bonds (the “**Bondowner**”); and

WHEREAS, in order to resolve the Bond Default and the Foreclosure Litigation, the District has agreed to issue the Community Facilities District No. 2007-1 (Montesoro) of the Borrego Water District Special Tax Refunding Bonds, Series 2017A (the “**Series 2017A Bonds**”) and the Borrego Water District Community Facilities District No. 2017-1 Borrego Water District Special Tax Refunding Bonds, Series 2017B (the “**Series 2017B Bonds**”) and, together with the Series 2017A

Bonds, the “**Refunding Bonds**”) for the purpose, among other things, of defeasing and redeeming the Series 2007 Bonds; and

WHEREAS, to facilitate the defeasance and redemption of the Series 2007 Bonds, the Bondowner has requested that the District consider certain additional amendments to the Indenture to, among other things, (i) authorize the optional redemption of the Series 2007 Bonds on any date after March 1, 2017 rather than on each Interest Payment Date from August 1, 2017, (ii) reduce the redemption price for any optional redemption from 102% of the principal amount of the Series 2007 Bonds to be redeemed to 100% of the principal amount and (iii) provide that the issuance of Refunding Bonds and the delivery of the Series 2007 Bonds to the District will cause the discharge of the Indenture; and

WHEREAS, the written consent of the Bondowner, as 100% owner of the Series 2007 Bonds, to this Amendment No. 3 has been received by the District and the Trustee in accordance with Section 6.2 of the Indenture.

**NOW, THEREFORE, IN CONSIDERATION OF THESE PREMISES AND OF THE MUTUAL AGREEMENTS AND COVENANTS CONTAINED HEREIN AND FOR OTHER VALUABLE CONSIDERATION, THE PARTIES HERETO DO HEREBY AGREE AS FOLLOWS:**

**Section 1.** Capitalized Terms. All capitalized terms not defined herein shall have the meanings set forth in Section 1.1 of the Indenture. The following term shall be added to Section 1.1:

“Refunding Bonds” shall mean the Community Facilities District No. 2007-1 (Montesoro) of the Borrego Water District Special Tax Refunding Bonds, Series 2017A and the Borrego Water District Community Facilities District No. 2017-1 Special Tax Refunding Bonds, Series 2017B.

**Section 2.** Amendment to Section 4.1(a). Section 4.1(a) of the Indenture is hereby amended and restated in its entirety to read as follows:

“(a) The Series 2007 Bonds maturing on or before August 1, 2016 are not subject to optional redemption prior to their maturity dates. The Series 2007 Bonds maturing on or after August 1, 2017 may be redeemed before maturity at the option of the District on any date on or after February 1, 2017 as a whole, or in part by lot from such maturities as are selected by the District, at a redemption price equal to the principal amount of the Series 2007 Bonds to be redeemed, plus accrued interest to the redemption date, without premium.”

**Section 3.** Amendment to Section 9.1. The following shall be added to the end of Section 9.1 of the Indenture:

“Notwithstanding the foregoing, this Indenture shall be discharged and the pledge of Net Taxes and all covenants, agreements and other obligations of the District provided for in this Indenture will terminate upon the issuance of the Refunding Bonds and the assignment by and the delivery of the Outstanding Series 2007 Bonds by the

Bondowners to the District and the subsequent delivery by the District of such bonds to the Trustee for cancellation pursuant to Section 10.1.”

**Section 4.** Execution in Counterparts. This Amendment No. 3 may be executed in several counterparts, each of which shall be an original and all of which shall constitute but one and the same instrument.

**Section 5.** Governing Law. THIS AMENDMENT NO. 3 SHALL BE CONSTRUED AND GOVERNED IN ACCORDANCE WITH THE LAWS OF THE STATE OF CALIFORNIA (WITHOUT REGARD TO CONFLICTS OF LAW).

**Section 6.** No Other Amendments. Except as amended by this Amendment No. 3, all other provisions of the Indenture shall remain in full force and effect.

**[REST OF THIS PAGE INTENTIONALLY LEFT BLANK]**

**IN WITNESS WHEREOF**, the parties hereto have executed and attested this Amendment No. 3 by their officers thereunto duly authorized as of the day and year first written above.

COMMUNITY FACILITIES DISTRICT NO. 2007-1  
(MONTESORO) OF BORREGO WATER  
DISTRICT

By: \_\_\_\_\_  
General Manager of the Borrego Water District,  
acting in its capacity as the legislative body of  
Community Facilities District No. 2007-1  
(Montesoro) of Borrego Water District,

ATTEST:

\_\_\_\_\_  
Secretary of the Governing Board of the  
Borrego Water District, acting in its capacity  
as the legislative body of Community Facilities  
District No. 2007-1 (Montesoro) of  
Borrego Water District

U.S. BANK NATIONAL ASSOCIATION, as Trustee

By: \_\_\_\_\_  
Its: Authorized Officer

The undersigned, as the Bondowner of all of the Outstanding Bonds, hereby acknowledges and consents to this Amendment No. 3 of the Indenture:

CONSIDINE FAMILY FOUNDATION,  
a Colorado nonprofit corporation

By: \_\_\_\_\_  
Terry Considine, Vice-President

**EXHIBIT D**

**IDENTIFIED CFD 2007-1 PARCELS**

2002811000	2003502000	2003506700
2002811400	2003502100	2003600100
2002811500	2003502200	2003600200
2002812000	2003502500	2003600300
2002812600	2003502700	2003600400
2002813400	2003502800	2003600500
2002830600	2003502900	2003600600
2002830700	2003503100	2003600700
2002830800	2003504300	2003600800
2003113700	2003504400	2003600900
2003113800	2003504500	2003601000
2003114300	2003504600	2003601100
2003114400	2003504700	2003601200
2003114500	2003504800	2003601300
2003114600	2003504900	2003601400
2003123200	2003505000	2003601500
2003123300	2003505100	2003601600
2003123400	2003505200	2004001500
2003123500	2003505300	2004001600
2003123600	2003505400	2004002600
2003407600	2003505500	2004003000
2003407700	2003505600	2004003100
2003407800	2003505800	2004006000
2003501300	2003505900	2004006100
2003501500	2003506200	2004010300
2003501600	2003506300	2004014500
2003501700	2003506400	2004015500
2003501800	2003506500	2004016900
2003501900	2003506600	2004017000

**Number of Parcels 87**

**EXHIBIT E**  
**CFD 2017-1 BOUNDARY MAP**



PROPOSED BOUNDARIES OF  
BORREGO WATER DISTRICT  
COMMUNITY FACILITIES DISTRICT NO. 2017-1  
COUNTY OF SAN DIEGO  
STATE OF CALIFORNIA

(1) Filed in the office of the Secretary of the Board of the Borrego Water District this \_\_\_\_ day of \_\_\_\_\_, 2017.

\_\_\_\_\_  
Secretary of the Board, Borrego Water District

(2) I hereby certify that the within map showing the proposed boundaries of Borrego Water District Community Facilities District No. 2017-1, San Diego County, State of California, was approved by the Board of Directors at a regular meeting thereof, held on this \_\_\_\_ day of \_\_\_\_\_, 2017, by its Resolution No. \_\_\_\_\_.

\_\_\_\_\_  
Secretary of the Board, Borrego Water District

(3) Filed this \_\_\_\_ day of \_\_\_\_\_, 2017, at the hour of \_\_\_\_ o'clock \_\_m, in Book \_\_\_\_\_ of Maps of Assessment and Community Facilities Districts at page \_\_\_\_\_ and as Instrument No. \_\_\_\_\_ in the office of the County Recorder of San Diego County, State of California.

Ernest J. Dronenburg, Jr.

Assessor/Recorder/County Clerk, County of San Diego

By \_\_\_\_\_

Deputy

Fee \_\_\_\_\_

PROPOSED BOUNDARIES OF  
BORREGO WATER DISTRICT  
COMMUNITY FACILITIES DISTRICT NO. 2017-1  
COUNTY OF SAN DIEGO  
STATE OF CALIFORNIA

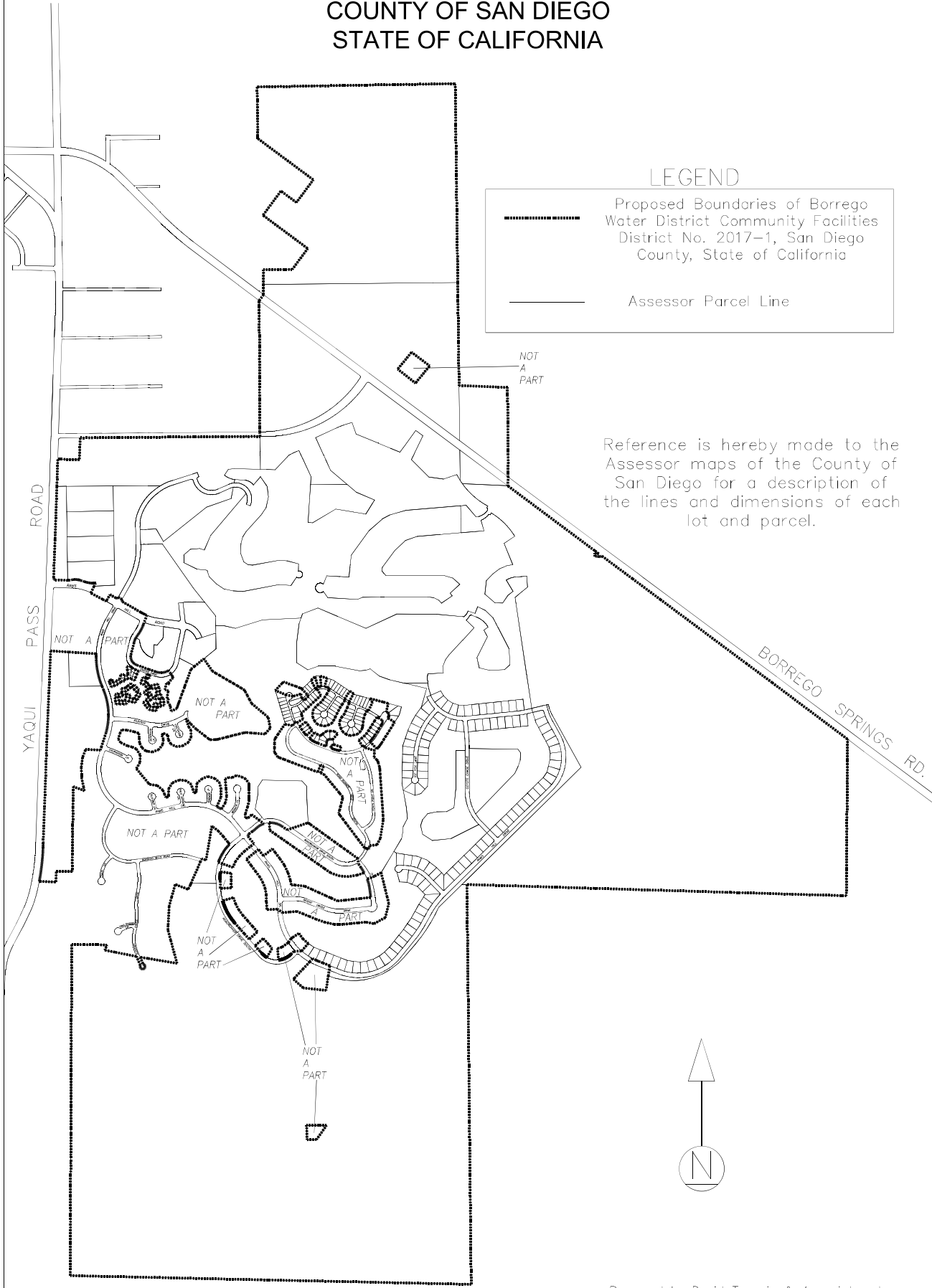

LEGEND

- Proposed Boundaries of Borrego Water District Community Facilities District No. 2017-1, San Diego County, State of California
- Assessor Parcel Line

Reference is hereby made to the Assessor maps of the County of San Diego for a description of the lines and dimensions of each lot and parcel.

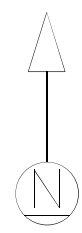

PROPOSED BOUNDARIES OF  
BORREGO WATER DISTRICT  
COMMUNITY FACILITIES DISTRICT NO. 2017-1  
COUNTY OF SAN DIEGO  
STATE OF CALIFORNIA

**Assessor Parcel Numbers within the  
Boundaries of Community Facilities District No. 2017-1:**

200-120-39  
200-120-41  
200-120-48  
200-120-51 through 200-120-53  
200-140-12  
200-160-30  
200-210-22  
200-271-03  
200-271-04  
200-271-06  
200-271-07  
200-271-15  
200-271-16  
200-271-21 through 200-271-24  
200-271-29  
200-271-34  
200-271-37  
200-272-08  
200-273-02 through 200-273-04  
200-273-06 through 200-273-08  
200-274-02  
200-275-08 through 200-275-11  
200-311-18  
200-330-23  
200-330-24  
200-330-27 through 200-330-29  
200-330-33  
200-330-34  
200-330-51  
200-330-76 through 200-330-81  
200-340-01  
200-340-04 through 200-340-07  
200-340-23  
200-340-53 through 200-340-75  
200-340-79 through 200-340-90  
200-350-01  
200-350-24  
200-360-17  
200-360-18  
200-370-03 through 200-370-36  
200-370-38  
200-380-01 through 200-380-28  
200-390-01 through 200-390-46  
200-400-01  
200-400-11 through 200-400-13  
200-400-17 through 200-400-24  
200-400-29  
200-400-32 through 200-400-49  
200-400-51 through 200-400-56  
200-401-01  
200-401-02  
200-401-04 through 200-401-06  
200-401-08 through 200-401-34  
200-401-36 through 200-401-42  
200-401-44  
200-401-46 through 200-401-48  
200-401-50  
200-401-51  
200-401-56 through 200-401-64

**EXHIBIT F**  
**RATE AND METHOD OF APPORTIONMENT FOR**  
**BORREGO WATER DISTRICT COMMUNITY FACILITIES**  
**DISTRICT NO. 2017-1**

**RATE AND METHOD OF APPORTIONMENT FOR  
BORREGO WATER DISTRICT  
COMMUNITY FACILITIES DISTRICT NO. 2017-1**

A Special Tax as hereinafter defined shall be levied on all Assessor's Parcels in Borrego Water District Community Facilities District No. 2017-1 ("CFD No. 2017-1") and collected each Fiscal Year commencing in Fiscal Year 2017-18, in an amount determined by the CFD Administrator of the Borrego Water District through the application of the Rate and Method of Apportionment as described below. All of the real property in CFD No. 2017-1, unless exempted by law or by the provisions hereof, shall be taxed for the purposes, to the extent and in the manner herein provided.

**A. DEFINITIONS**

The terms hereinafter set forth have the following meanings:

**"Acre" or "Acreage"** means the land area of an Assessor's Parcel as shown on an Assessor's Parcel Map, or if the land area is not shown on an Assessor's Parcel Map, the land area shown on the applicable final map, parcel map, condominium plan, or other recorded County parcel map. Lot size equals Acreage multiplied by 43,560.

**"Act"** means the Mello-Roos Community Facilities Act of 1982, as amended, being Chapter 2.5, Division 2 of Title 5 of the Government Code of the State of California.

**"Administrative Expenses"** means the following actual or reasonably estimated costs directly related to the administration of CFD No. 2017-1: the costs of computing the Special Taxes and preparing the annual Special Tax collection schedules (whether by the Water District or designee thereof or both); the costs of collecting the Special Taxes (whether by the County or otherwise); the costs of remitting the Special Taxes to the Fiscal Agent; the costs of the Fiscal Agent (including its legal counsel) in the discharge of the duties required of it under the Fiscal Agent Agreement; the costs to the Water District, CFD No. 2017-1 or any designee thereof of complying with arbitrage rebate requirements; the costs to the Water District, CFD No. 2017-1 or any designee thereof of complying with Water District, CFD No. 2017-1 or obligated persons disclosure requirements associated with applicable federal and state securities laws and of the Act; the costs associated with preparing Special Tax disclosure statements and responding to public inquiries regarding the Special Taxes; the costs of the Water District, CFD No. 2017-1 or any designee thereof related to an appeal of the Special Tax; the costs associated with the release of funds from any escrow account; and the Water District's annual administration fees, and third party expenses. Administrative Expenses shall also include amounts estimated or advanced by the Water District or CFD No. 2017-1 for any other administrative purposes of CFD No. 2017-1, including attorney's fees and other costs related to commencing and pursuing any foreclosure or other resolution of delinquent Special Taxes.

**"Assessor's Parcel"** means a lot or parcel shown in an Assessor's Parcel Map with an assigned Assessor's parcel number.

**"Assessor's Parcel Map"** means an official map of the Assessor of the County designating parcels by Assessor's parcel number.

**"Board"** means the Board of Directors of the Water District.

**"Bond Owner"** means (i) Considine Family Foundation, a Colorado nonprofit corporation, or (ii) a Related Party.

**"Bonds"** means any bonds or other debt (as defined in Section 53317(d) of the Act), whether in one or more series, issued by CFD No. 2017-1 under the Act.

**"CFD Administrator"** means an official of the Water District, or designee thereof, responsible for determining the Special Tax Requirement and providing for the levy and collection of the Special Taxes.

**"CFD No. 2017-1"** means Borrego Water District Community Facilities District No. 2017-1.

**"County"** means the County of San Diego.

**"Developed Property"** means, for each Fiscal Year, all Assessor's Parcels of Taxable Property for which a building permit for purposes of constructing a new residential or non-residential development has been issued by the County after January 1, 2017 and as of January 1 of the prior Fiscal Year.

**"Exempt Property"** means the geographic area identified as Exempt Property in Exhibit A herein.

**"Fiscal Agent"** means the fiscal agent under the Fiscal Agent Agreement.

**"Fiscal Agent Agreement"** means the fiscal agent agreement, indenture, resolution or other instrument pursuant to which Bonds are issued, as modified, amended and/or supplemented from time to time.

**"Fiscal Year"** means the period starting July 1 and ending on the following June 30.

**"Maximum Special Tax"** means the Maximum Special Tax, determined in accordance with Section C below, that can be levied in any Fiscal Year on any Assessor's Parcel.

**"Outstanding Bonds"** means all Bonds which are deemed to be outstanding under the Fiscal Agent Agreement.

**"Property Owner Association Property"** means, for each Fiscal Year, any property within the boundaries of CFD No. 2017-1 that was owned by a property owner association, including any master or sub-association, as of January 1 of the prior Fiscal Year.

**"Proportionately"** means, for Developed Property, that the ratio of the actual Special Tax levy to the Maximum Special Tax is equal for all Assessor's Parcels of Developed Property. For Undeveloped Property, "Proportionately" means that the ratio of the actual Special Tax levy per Acre to the Maximum Special Tax per Acre is equal for all Assessor's Parcels of Undeveloped Property.

**"Public Property"** means, for each Fiscal Year, any property within CFD No. 2017-1 that is owned by, irrevocably offered for dedication to, or dedicated to the federal government, the State, the County, the Water District or any other public agency as of June 30 of the prior Fiscal Year; provided however that any property leased by a public agency to a private entity and subject to taxation under Section 53340.1 of the Act shall be taxed and classified in accordance with its use. To ensure that property is classified as Public Property in the first Fiscal Year after it is acquired by, irrevocably offered for dedication to, or dedicated to a public agency, the property owner shall notify the CFD Administrator in writing of such acquisition, offer, or dedication not later than June 30 of the Fiscal Year in which the acquisition, offer, or dedication occurred.

**"Related Party"** means any person or entity in which Terry Considine and/or Betsy Considine has direct or indirect control over.

**"Special Tax(es)"** means the special tax(es) to be levied in each Fiscal Year on each Assessor's Parcel of Taxable Property to fund the Special Tax Requirement.

**"Special Tax Requirement following sale of Bonds to a Third Party"** means that amount required in any Fiscal Year for CFD No. 2017-1 to: (i) pay debt service on all Outstanding Bonds; (ii) pay periodic costs on the Bonds, including but not limited to, credit enhancement and rebate payments on the Bonds; (iii) pay Administrative Expenses; (iv) pay any amounts required to establish or replenish any reserve funds for all Outstanding Bonds; (v) pay for reasonably anticipated delinquent Special Taxes based on the delinquency rate for Special Taxes levied in the previous Fiscal Year; less (vi) a credit for funds available to reduce the annual Special Tax levy, as determined by the CFD Administrator pursuant to the Fiscal Agent Agreement.

**"Special Tax Requirement for Bonds held by Bond Owner"** means that amount required in any Fiscal Year for CFD No. 2017-1 to: (i) pay debt service on all Outstanding Bonds; (ii) pay periodic costs on the Bonds, including but not limited to, credit enhancement and rebate payments on the Bonds; (iii) pay Administrative Expenses; less (iv) a credit for funds available to reduce the annual Special Tax levy, as determined by the CFD Administrator pursuant to the Fiscal Agent Agreement.

**"State"** means the State of California.

**"Taxable Property"** means all of the Assessor's Parcels within the boundaries of CFD No. 2017-1 which are not exempt from the Special Tax pursuant to law or Section E below.

**"Third Party"** means an entity other than the Bond Owner.

"**Undeveloped Property**" means, for each Fiscal Year, all Taxable Property not classified as Developed Property.

"**Water District**" means the Borrego Water District.

**B. ASSIGNMENT TO LAND USE CATEGORIES**

Each Fiscal Year, commencing Fiscal Year 2017-18, all Taxable Property within CFD No. 2017-1 shall be classified as Developed Property or Undeveloped Property, and shall be subject to Special Taxes in accordance with the rate and method of apportionment determined pursuant to Sections C and D below.

**C. MAXIMUM SPECIAL TAX**

**1. Developed Property**

The Maximum Special Tax for each Assessor's Parcel classified as Developed Property shall be equal to \$740 per Acre.

**2. Undeveloped Property**

The Maximum Special Tax for Undeveloped Property in CFD No. 2017-1 shall equal \$740 per Acre.

**D. METHOD OF APPORTIONMENT OF THE SPECIAL TAX**

For each Fiscal Year, commencing Fiscal Year 2017-18, if Bonds have been sold to a Third Party, then the Board shall determine the Special Tax Requirement following sale of Bonds to a Third Party and shall levy the Special Tax as described below. If Bonds have not yet been sold to a Third Party, then the Board shall determine the Special Tax Requirement for Bonds held by Bond Owner and shall levy the Special Tax as described below.

First: The Special Tax shall be levied Proportionately on each Assessor's Parcel of Developed Property at up to 100% of the applicable Maximum Special Tax; and

Second: If additional monies are needed to satisfy the Special Tax Requirement after the first step has been completed, the Special Tax shall be levied Proportionately on each Assessor's Parcel of Undeveloped Property at up to 100% of the Maximum Special Tax for Undeveloped Property.

Notwithstanding the above, under no circumstances will the Special Tax levied in a Fiscal Year against any Assessor's Parcel of Developed Property for which an occupancy permit for private residential use has been issued be increased by more than ten percent (10%) above the amount that would have been levied in that Fiscal Year as a consequence of delinquency or default by the owner of any other Assessor's Parcel within CFD No. 2017-1. To the extent that the levy of the Special Tax on residential property is limited by the provision in the



previous sentence, the levy of the Special Tax on all other Assessor's Parcels shall continue in equal percentages at up to 100% of the Maximum Special Tax.

**E. EXEMPTIONS**

No Special Tax shall be levied on the Exempt Property identified in Exhibit A.

In addition, no Special Tax shall be levied on Property Owner Association Property and Public Property.

**F. APPEALS AND INTERPRETATIONS**

Any property owner claiming that the amount or application of the Special Tax with respect to his or her Assessor's Parcel is not correct and requesting a refund may file a written notice of appeal and refund to that effect with the CFD Administrator not later than one calendar year after having paid the Special Tax that is disputed. The CFD Administrator shall promptly review the appeal, and if necessary, meet with the property owner, consider written and oral evidence regarding the amount of the Special Tax, and decide the appeal. If the CFD Administrator's decision requires the Special Tax be modified or changed in favor of the property owner, a cash refund shall not be made (except for the last year of levy), but an adjustment shall be made to the next Special Tax levy. Any dispute over the decision of the CFD Administrator shall be referred to the Board and the decision of the Board shall be final.

This procedure shall be exclusive and its exhaustion by any property owner shall be a condition precedent to any legal action by such owner.

Interpretations may be made by the Board by ordinance or resolution for purposes of clarifying any vagueness or ambiguity in this Rate and Method of Apportionment.

**G. MANNER OF COLLECTION**

The Special Tax will be collected in the same manner and at the same time as ordinary *ad valorem* property taxes; provided, however, that CFD No. 2017-1 may directly bill the Special Tax, may collect Special Taxes at a different time or in a different manner if necessary to meet its financial obligations, and may covenant to foreclose and may actually foreclose on delinquent Assessor's Parcels as permitted by the Act.

**H. PREPAYMENT OF SPECIAL TAX**

The following definition applies to this Section H:

**"Bond Redemption Date"** means the redemption date pursuant to the Fiscal Agent Agreement for the Outstanding Bonds to be redeemed with the prepayment.

**"Outstanding Bonds"** means all Previously Issued Bonds which are deemed to be outstanding under the Fiscal Agent Agreement after the first interest and/or principal payment date following the current Fiscal Year.

**"Previously Issued Bonds"** means all Bonds that have been issued by CFD No. 2017-1 prior to the date of prepayment.

**1. Prepayment in Full**

The obligation of an Assessor's Parcel of Developed Property or Undeveloped Property to pay the Special Tax may be prepaid and permanently satisfied as described herein; provided that (i) Bonds have been issued and (ii) there are no delinquent Special Taxes with respect to such Assessor's Parcel at the time of prepayment. An owner of an Assessor's Parcel intending to prepay the Special Tax obligation shall provide the CFD Administrator with written notice of intent to prepay. Within 30 days of receipt of such written notice, the CFD Administrator shall notify such owner of the prepayment amount for such Assessor's Parcel. The CFD Administrator may charge a reasonable fee for providing this service.

The Prepayment Amount (defined below) shall be calculated as summarized below (capitalized terms as defined below):

	Bond Redemption Amount
plus	Redemption Premium
plus	Defeasance Amount
plus	Administrative Fees and Expenses
less	<u>Reserve Fund Credit</u>
Total: equals	Prepayment Amount

As of the proposed date of prepayment, the Prepayment Amount (defined below) shall be calculated as follows:

**Step No.:**

1. Confirm that no Special Tax delinquencies apply to such Assessor's Parcel.
2. Compute the Maximum Special Tax applicable for the Assessor's Parcel to be prepaid.
3. Divide the Maximum Special Tax, computed pursuant to paragraph 2, by the total estimated Maximum Special Taxes for the entire CFD No. 2017-1 based on the Maximum Special Taxes which could be charged in the current Fiscal Year in CFD No. 2017-1.
4. Multiply the quotient computed pursuant to paragraph 3 by the Outstanding Bonds to compute the amount of Outstanding Bonds to be retired and prepaid (the "Bond Redemption Amount").

5. Multiply the Bond Redemption Amount computed pursuant to paragraph 4 by the applicable redemption premium, if any, as set forth in the Fiscal Agent Agreement, on the Outstanding Bonds to be redeemed (the "Redemption Premium").
6. Compute the amount needed to pay interest on the Bond Redemption Amount from the first bond interest and/or principal payment date following the current Fiscal Year until the Bond Redemption Date.
7. Determine the Special Taxes levied on the Assessor's Parcel in the current Fiscal Year which have not yet been paid.
8. Compute the minimum amount the CFD Administrator reasonably expects to derive from the reinvestment of the Prepayment Amount (as defined below) less the Administrative Fees and Expenses (as defined below) from the date of prepayment until the Bond Redemption Date.
9. Add the amounts computed pursuant to paragraphs 6 and 7 and subtract the amount computed pursuant to paragraph 8 (the "Defeasance Amount").
10. Verify the administrative fees and expenses of CFD No. 2017-1, including the costs of computation of the prepayment, the costs to invest the prepayment proceeds, the costs of redeeming Bonds, and the costs of recording any notices to evidence the prepayment and the redemption (the "Administrative Fees and Expenses").
11. If reserve funds for the Outstanding Bonds, if any, are at or above 100% of the reserve requirement (as defined in the Fiscal Agent Agreement) on the prepayment date, a reserve fund credit shall be calculated based on a reduction in the applicable reserve fund for the Outstanding Bonds, as set forth in the Fiscal Agent Agreement, to be redeemed pursuant to the prepayment (the "Reserve Fund Credit"). No Reserve Fund Credit shall be granted if reserve funds are below 100% of the reserve requirement.
12. The Special Tax prepayment is equal to the sum of the amounts computed pursuant to paragraphs 4, 5, 9 and 10, less the amount computed pursuant to paragraph 11 (the "Prepayment Amount").
13. From the Prepayment Amount, the amounts computed pursuant to paragraphs 4, 5, 9 and 11 shall be deposited into the appropriate fund as established under the Fiscal Agent Agreement and be used to retire Outstanding Bonds or make debt service payments. The amount computed pursuant to paragraph 10 shall be retained by CFD No. 2017-1.

The Prepayment Amount may be sufficient to redeem other than a \$5,000 increment of Bonds. In such cases, the increment above \$5,000 or integral multiple thereof will be retained in the appropriate fund established under the Fiscal Agent Agreement to be used with the next prepayment of Bonds or to make debt service payments.

As a result of the payment of the current Fiscal Year's Special Tax levy as determined under paragraph 7 (above), the CFD Administrator shall remove the current Fiscal Year's Special Tax levy for such Assessor's Parcel from the County tax rolls. With respect to any Assessor's Parcel that is prepaid, the Board shall cause a suitable notice to be recorded in compliance with the Act, to indicate the prepayment of Special Taxes and the release of the Special Tax lien on such Assessor's Parcel, and the obligation of such Assessor's Parcel to pay the Special Tax shall cease.

Notwithstanding the foregoing, no Special Tax prepayment shall be allowed unless the amount of Maximum Special Taxes that may be levied on all property in CFD No. 2017-1, both prior to and after the proposed prepayment, less expected Administrative Expenses, is at least 1.1 times the maximum annual debt service on all Outstanding Bonds.

## **2. Prepayment in Part**

The Special Tax on an Assessor's Parcel located in CFD No. 2017-1 may be partially prepaid. The amount of the prepayment shall be calculated as in Section H.1; except that a partial prepayment shall be calculated according to the following formula:

$$PP = (P_E - A) \times F + A$$

These terms have the following meaning:

- PP = the partial prepayment
- P<sub>E</sub> = the Prepayment Amount calculated according to Section H.1
- F = the percentage by which the owner of the Assessor's Parcel(s) is partially prepaying the Special Tax.
- A = the Administration Fees and Expenses from Section H.1

The owner of any Assessor's Parcel who desires such prepayment shall notify the CFD Administrator of such owner's intent to partially prepay the Special Tax and the percentage by which the Special Tax shall be prepaid. The CFD Administrator shall provide the owner with a statement of the amount required for the partial prepayment of the Special Tax for an Assessor's Parcel within thirty (30) days of the request and may charge a reasonable fee for providing this service. With respect to any Assessor's Parcel that is partially prepaid, the Water District shall (i) distribute the funds remitted to it according to Section H.1, and (ii) indicate in the records of CFD No. 2017-1 that there has been a partial prepayment of the Special Tax and that a portion of the Special Tax with respect to such Assessor's Parcel, equal to the outstanding percentage (1.00 - F) of the remaining Maximum Special Tax, shall continue to be levied on such Assessor's Parcel pursuant to Section D.

Notwithstanding the foregoing, no Special Tax prepayment shall be allowed unless the amount of Maximum Special Taxes that may be levied all property in CFD No. 2017-1, both prior to and after the proposed prepayment, less expected Administrative Expenses, is at least 1.1 times the maximum annual debt service on all Outstanding Bonds.

**I. TERM OF SPECIAL TAX**

The Special Tax shall be levied for a period not to exceed forty years commencing in Fiscal Year 2017-18.

## **EXHIBIT A**

EXEMPT LOTS WITHIN THE  
 PROPOSED BOUNDARIES OF  
 BORREGO WATER DISTRICT  
 COMMUNITY FACILITIES DISTRICT NO. 2017-1  
 COUNTY OF SAN DIEGO  
 STATE OF CALIFORNIA

LEGEND

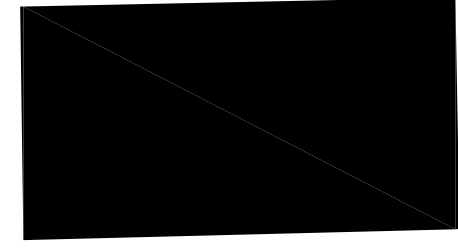
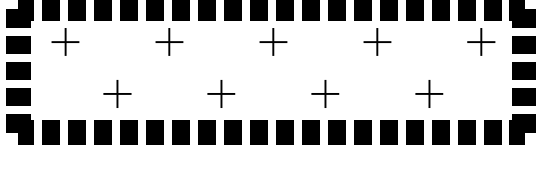
 Exempt Lots within the Proposed Boundaries of Borrego Water District Community Facilities District No. 2017-1, San Diego County, State of California  
 Area within C.F.D. Boundary

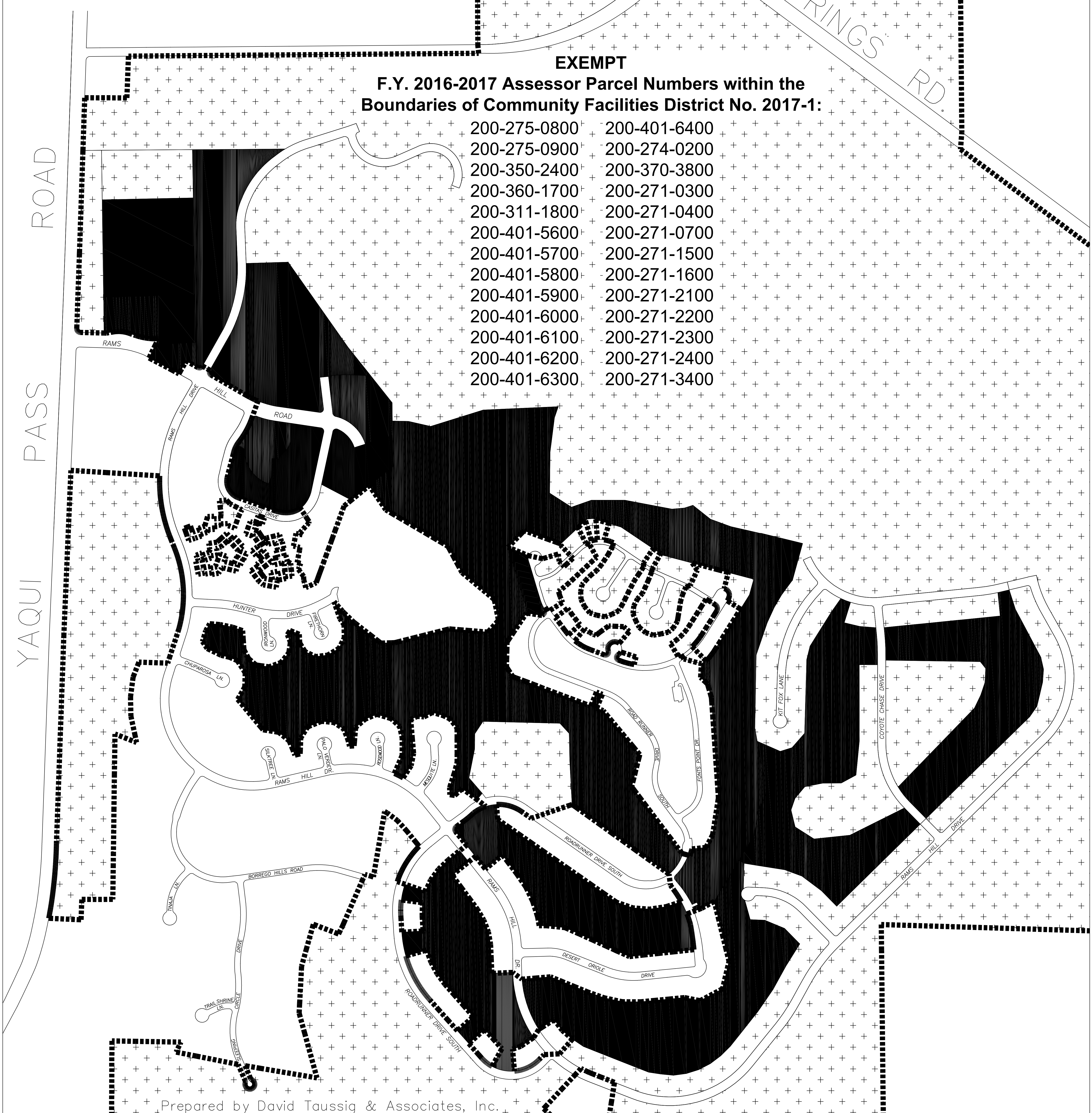
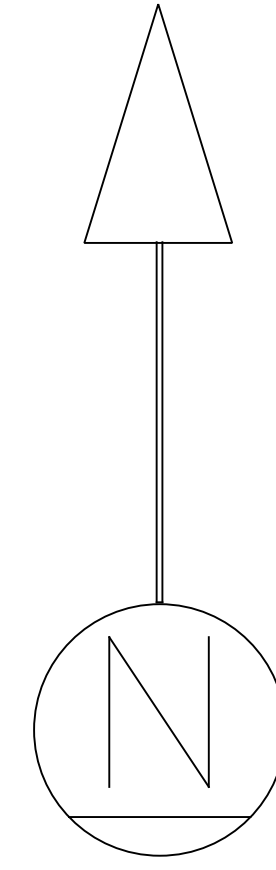

**EXEMPT  
 F.Y. 2016-2017 Assessor Parcel Numbers within the  
 Boundaries of Community Facilities District No. 2017-1:**

200-275-0800	200-401-6400
200-275-0900	200-274-0200
200-350-2400	200-370-3800
200-360-1700	200-271-0300
200-311-1800	200-271-0400
200-401-5600	200-271-0700
200-401-5700	200-271-1500
200-401-5800	200-271-1600
200-401-5900	200-271-2100
200-401-6000	200-271-2200
200-401-6100	200-271-2300
200-401-6200	200-271-2400
200-401-6300	200-271-3400



**BEST BEST & KRIEGER**  
**ATTORNEYS AT LAW**

Indian Wells  
(760) 568-2611

Irvine  
(949) 263-2600

Los Angeles  
(213) 617-8100

Ontario  
(909) 989-8584

655 West Broadway, 15<sup>th</sup> Floor, San Diego, CA 92101  
Phone: (619) 525-1300 | Fax: (619) 233-6118 | www.bbklaw.com

Riverside  
(951) 686-1450

Sacramento  
(916) 325-4000

Walnut Creek  
(925) 977-3300

Washington, DC  
(202) 785-0600

**Warren B. Diven**  
Partner  
(619) 525-1337  
warren.diven@bbklaw.com

**Memorandum**

**To:** President and Board of Directors, Borrego Water District  
**From:** Warren B. Diven  
**Date:** March 10, 2017  
**Re:** Board of Directors Meeting March 14, 2017 Agenda Bill II.A -  
Initiation of Proceedings to Consider the Establishment of Borrego Water  
District No. 2017-1

**Background.**

The Borrego Water District (“BWD”) has entered into a Settlement Agreement by and among T2 Borrego LLC, T2 Holding LLC, and Considine Family Foundation on the one hand, and Borrego Water District, for itself and on behalf of Community Facilities District No. 2007-1 (Montesoro) of the Borrego Water District, on the other hand (the “Settlement Agreement”) for the purpose restructuring the outstanding Community Facilities District No. 2007-1 (Montesoro) of the Borrego Water District (the “CFD No. 2007-1 Bonds”) and settling certain litigation related to the delinquency in the payment of special taxes levied within Community Facilities District No. 2007-1 (Montesoro) of the Borrego Water District (“CFD No. 2007-1”).<sup>1</sup>

The Settlement Agreement provided that the Board of Directors of BWD would take the actions necessary to establish and form the Borrego Water District Community Facilities District No. 2017-1 (“CFD No. 2017-1”) for the purpose of defeasing or waiving and discharging a portion of the principal amount of the outstanding CFD No. 2007-1 Bonds. The resolutions presented to the Board of Directors at this meeting and described below will initiate the formal proceedings to establish CFD No. 2017-1

**Description of the Resolutions Initiating the Proceedings to Establish CFD No. 2017-1.**

**Resolution Adopting a Map Showing the Boundaries of Territory Proposed to be Included in CFD No. 2017-1.**

By adoption of this resolution the Board of Directors will be approving and adopting the map designated as “Proposed Boundaries of Borrego Water District Community Facilities District No. 2017-1, County of San Diego, State of California” (the “Boundary Map”).

<sup>1</sup> See the separate memorandum summarizing certain provisions of such Settlement Agreement.  
61170.00001\29621490.1





**BEST BEST & KRIEGER**  
ATTORNEYS AT LAW

The Boundary Map depicts the territory proposed to be included in CFD No. 2017-1 and to be subject to the levy of a special tax of CFD No. 2017-1. The territory includes all of that territory included within the boundaries of CFD No. 2007-1 with the exception of 66 residential parcels owned by homeowners and 21 residential parcels owned by T2 Borrego LLC that are identified in the Settlement Agreement.

This boundary map will be recorded in the office of the Recorder of the County of San Diego and will give notice to any prospective purchaser of any parcel within such territory of the pendency of the proceedings to establish CFD No. 2017-1.

**Resolution Declaring the Intention of the Board of Directors to Establish CFD No. 2017-1.**

By adoption of this resolution the Board of Directors will, among other actions, be:

- declaring the intention of the Board to finance the purchase and the defeasance of the obligation to pay a portion of the principal of and certain accrued and unpaid interest on the CFD No. 2007-1 Bonds (the “Defeasance and Discharge”);
- proposing the levy of a special tax within CFD No. 2017-1 sufficient to pay for: (a) the Defeasance and the Discharge and related incidental expenses, and (b) the principal and interest on bonds or other indebtedness of CFD No. 2017-1;
- setting the time and place for a public hearing to be held on April 18, 2017 to consider the establishment of CFD No. 2017-1, the rate and method of apportionment of the proposed special taxes and all other matters set forth in this resolution;
- directing the preparation of a report for presentation at the public hearing pertaining to the Defeasance and Discharge and the estimate for the cost of the Defeasance and Discharge; and
- directing that notice of such public hearing be given by publication at least seven (7) days prior to the date set for the public hearing.

**Resolution Declaring the Necessity to Incur a Bonded Indebtedness of CFD No. 2017-1.**

By adoption of this resolution the Board of Directors will, among other actions, be:



**BEST BEST & KRIEGER**  
ATTORNEYS AT LAW

- declaring that the public convenience and necessity require a bonded indebtedness be incurred by CFD No. 2017-1 to contribute to the financing of the Defeasance and Discharge;
- determining that the amount of such indebtedness shall not exceed \$10,500,000;
- setting the time and place for a public hearing to be held on April 18, 2017 related to the proposed bonded indebtedness;
- directing that notice of such public hearing be given by publication at least seven (7) days prior to the date set for the public hearing.

**Summary of the Next Steps.**

Following the adoption of the foregoing resolutions, the major steps remaining to establish CFD No. 2017-1 and complete the restructuring of the CFD No. 2007-1 Bonds and the requirements of the Settlement Agreement are as follows:

- April 18, 2016 –
  - Board of Directors conducts the consolidated public hearings (a) to consider the establishment of CFD No. 2017-1 and (b) to incur a bonded indebtedness of CFD No. 2017-1.
  - Board of Directors considers the adoption of the resolutions establishing CFD No. 2017-1 and determining the necessity to incur a bonded indebtedness of CFD No. 2017-1;
  - The Secretary of the Board of Directors canvases the ballots of the qualified electors on the questions of authorizing the bonded indebtedness of CFD No. 2017-1, the levy of special taxes within CFD No. 2017-1 and the establishment of an appropriations limit for CFD No. 2017-1.
  - If the ballot measures pass, the Board of Directors considers the adoption of a resolution declaring the results of the electing and introducing and waiving the first reading of an ordinance authorizing the levy of special taxes within CFD No. 2017-1.
- April 26, 2017
  - Board of Directors, acting as the legislative body of CFD No. 2007-1, considers the adoption of a resolution authorizing the



**BEST BEST & KRIEGER**  
ATTORNEYS AT LAW

issuance of refunding bonds of CFD No. 2007-1 (identified in the Settlement Agreement as the Series 2017A Bonds). By adoption of this resolution the Board of Directors will also approve the form of a Fiscal Agent Agreement that will establish the terms under which such bonds will be issued including the principal amount of such bonds and the interest rate on such bonds.

- Board of Directors, acting as the legislative body of CFD No. 2017-1, considers the adoption of a resolution authorizing the issuance of bonds of CFD No. 2017-1 (identified in the Settlement Agreement as the Series 2017B Bonds). By adoption of this resolution the Board of Directors will also approve the form of a Fiscal Agent Agreement that will establish the terms under which such bonds will be issued including the principal amount of such bonds and the interest rate on such bonds.
- May 24, 2017
  - Pre-closing of the Series 2017A Bonds and Series 2017B Bonds
- May 25, 2017
  - Closing of the Series 2017A Bonds and Series 2017B Bonds
  - Defeasance and discharge of the CFD No. 2007-1 Bonds
- As soon as practicable thereafter, dismissal of the foreclosure litigation.

We would welcome any questions from the Board regarding the resolutions presented to the Board or the summary of the next steps.

cc: Geoff Poole, General Manager

RESOLUTION NO. 2017-03-02

RESOLUTION OF THE BOARD OF DIRECTORS OF THE BORREGO WATER DISTRICT ADOPTING A MAP SHOWING THE BOUNDARIES OF THE TERRITORY PROPOSED TO BE INCLUDED IN BORREGO WATER DISTRICT COMMUNITY FACILITIES DISTRICT NO. 2017-1

WHEREAS, the Board of Directors (the “Board”) of the Borrego Water District (“District”), desires to initiate proceedings to create a community facilities district pursuant to the terms and provisions of the “Mello-Roos Community Facilities Act of 1982”, being Chapter 2.5, Part 1, Division 2, Title 5 of the Government Code of the State of California (the “Act”). This Community Facilities District shall hereinafter be designated as Borrego Water District Community Facilities District No. 2017-1 (“CFD No. 2017-1”); and

WHEREAS, there has been submitted a map showing the boundaries of the territory proposed for inclusion in CFD No. 2017-1 including properties and parcels of land proposed to be subject to the levy of a special tax by CFD No. 2017-1.

NOW, THEREFORE, IT IS HEREBY RESOLVED:

SECTION 1. The above recitals are all true and correct.

SECTION 2. The map designated as “Proposed Boundaries of Borrego Water District Community Facilities District No. 2017-1, County of San Diego, State of California” showing the boundaries of the territory proposed for inclusion CFD No. 2017-1 including the parcels of land proposed to be subject to the levy of a special tax by CFD No. 2017-1 is hereby approved and adopted.

SECTION 3. A certificate shall be endorsed on the original and on at least one (1) copy of the map of CFD No. 2017-1, evidencing the date and adoption of this Resolution, and within fifteen (15) days after the adoption of the Resolution fixing the time and place of the hearing on the formation or extent of CFD No. 2017-1, a copy of such map shall be filed with the correct and proper endorsements thereon with the County Recorder, all in the manner and form provided for in Sections 3110 and 3111 of the Streets and Highways Code of the State of California.

SECTION 4. This resolution shall be effective upon its adoption.

ADOPTED, SIGNED AND APPROVED this \_\_\_\_\_ day of \_\_\_\_\_,  
2017.

---

President of the Board of Directors of  
Borrego Water District

ATTEST:

---

Secretary of the Board of Directors of  
Borrego Water District

61170.00001\29558875.1  
2/10/17

RESOLUTION NO. 2017-03-03

RESOLUTION OF THE BOARD OF DIRECTORS OF THE BORREGO WATER DISTRICT, DECLARING ITS INTENTION TO ESTABLISH BORREGO WATER DISTRICT COMMUNITY FACILITIES DISTRICT NO. 2017-1

WHEREAS, the Borrego Water District (the “District”) has formed its Community Facilities District No. 2007-1 (Montesoro) of the Borrego Water District (“CFD No. 2007-1”) and, in connection therewith, has issued its Borrego Water District Community Facilities District No. 2007-1 (Montesoro) Series 2007 Special Tax Bonds in the original principal amount of \$9,520,000 (the “2007 Bonds”) which are secured by special taxes levied by the District on property within the boundaries of CFD No. 2007-1, and the 2007 Bonds are currently in default; and

WHEREAS, the Board of Directors (the “Board”) of the District, at this time desires to initiate proceedings to create a Community Facilities District pursuant to the terms and provisions of the “Mello-Roos Community Facilities Act of 1982”, being Chapter 2.5, Part 1, Division 2, Title 5 of the Government Code of the State of California (the “Act”) for the purpose of purchasing and defeasing the obligation to pay a portion of the principal of and certain accrued and unpaid interest on 2007 Bonds secured by the special taxes authorized to be levied by CFD No. 2007-1. This Community Facilities District shall hereinafter be referred to as Borrego Water District Community Facilities District No. 2017-1 (CFD No. 2017-1); and

WHEREAS, this Board desires to proceed to adopt its Resolution of Intention to initiate the proceedings to consider the establishment of such District, to set forth the proposed boundaries for such District, to indicate the purpose for establishing the CFD, to indicate the proposed rate and apportionment of a special tax sufficient to finance any indebtedness incurred by CFD No. 2017-1, to set a time and place for a public hearing relating to the establishment of such District; and

WHEREAS, the Act provides that the Board may initiate proceedings to establish a community facilities district only if it has first considered and adopted local goals and policies concerning the use of community facilities districts; and

WHEREAS, this Board has adopted local goals and policies as required pursuant to the Act; and

NOW, THEREFORE, IT IS HEREBY RESOLVED:

SECTION 1. Recitals. The above recitals are all true and correct.

SECTION 2. Initiation of Proceedings. These proceedings are initiated by this Board pursuant to the authorization of the Act.

SECTION 3. Boundaries of District. It is the intention of this Board to establish the boundaries of the proposed District. A description of the proposed boundaries of the territory to be included in CFD No. 2017-1 and subject to the levy of a special tax by CFD No. 2017-1 is as follows:

All that property as shown on a map as previously approved by this Board, such map entitled “Proposed Boundaries of Borrego Water District Community Facilities District No. 2017-1, County of San Diego, State of California”, a copy of which is on file with the Board Secretary and shall remain open for public inspection.

SECTION 4. Name of District. The name of the proposed District shall be Borrego Water District Community Facilities District No. 2017-1.

SECTION 5. Purpose for Establishing the District. In accordance with Government Code Section 53313.5, it is the intention of this Board to finance the purchase and the defeasance of the obligation to pay a portion of the principal of and certain accrued and unpaid interest on the 2007 Bonds secured by the special taxes authorized to be levied by CFD No. 2007-1 (the “Defeasance and Discharge”).

The cost of the Defeasance and Discharge also includes Incidental Expenses as such term is defined in Government Code Section 53317(e) and may include, but not be limited to, all costs associated with the establishment of CFD No. 2017-1, the issuance and administration of bonds to be issued for CFD No. 2017-1, including the payment of any rebate obligation due and owing to the federal government, the determination of the amount of any special taxes to be levied, the costs of collecting any special taxes, and costs otherwise incurred in order to carry out the authorized purposes of CFD No. 2017-1.

SECTION 6. Special Tax. It is hereby further proposed that, except where funds are otherwise available, a special tax sufficient to pay for: (a) the Defeasance and Discharge and related Incidental Expenses authorized by the Act and (b) the principal and interest and other periodic costs on bonds or other indebtedness issued or incurred to finance the Defeasance and Discharge, secured by recordation of a continuing lien against all non-exempt real property in CFD No. 2017-1, will be levied annually within the boundaries of CFD No. 2017-1.

Under no circumstances will the special tax levied in any fiscal year against any parcel used for private residential purposes be increased as a consequence of delinquency or default by the owner of any other parcel or parcels within the same Improvement Area by more than 10 percent (10%) above the amount that would have been levied in that fiscal year had there never been any such delinquencies or defaults. For further particulars as to the rate and method of apportionment of the proposed special tax for CFD No. 2017-1 (the “Rate and Method of

Apportionment”) reference is made to the attached and incorporated Exhibit A, which sets forth in sufficient detail the method of apportionment to allow each landowner or resident within CFD No. 2017-1 to clearly estimate the maximum amount that such person will have to pay. The Rate and Method of Apportionment also sets forth the tax year after which no further special tax shall be levied or collected against any parcel used for private residential purposes within CFD No. 2017-1. A parcel shall be considered “used for private residential purposes” not later than the date on which an occupancy permit or the equivalent for private residential use is issued for such parcel.

The special taxes herein proposed, to the extent possible, shall be collected through a direct billing procedure by the General Manager of the District, acting for and on behalf of CFD No. 2017-1 so long as the taxable property within CFD No. 2017-1 shall be owned by T2 Borrego LLC, a Colorado limited liability company ("Borrego"), T2 Holding LLC, a Colorado limited liability company, or a related entity. If ownership of any taxable property within CFD No. 2017-1 is transferred to a third party, the special taxes shall thereafter be collected in the same manner as ad valorem property taxes or in such other manner at this Board shall determine, including without limitation, direct billing of the affected property owners, and shall be subject to the same penalties, procedure, sale and lien priority in any case of delinquency as applicable for ad valorem taxes. Any special taxes that may not be collected on the County tax roll shall be collected through a direct billing procedure by the General Manager of the District, acting for and on behalf of CFD No. 2017-1.

The special tax obligation for any parcel may be prepaid and permanently satisfied in whole or in part pursuant to the provisions therefor contained in the Rate and Method of Apportionment.

**SECTION 7. Public Hearing.** NOTICE IS GIVEN THAT ON APRIL 18, 2017, AT THE HOUR OF 9:00 A.M., IN THE REGULAR MEETING PLACE OF THE BOARD LOCATED AT 806 PALM CANYON DRIVE, BORREGO SPRINGS, CALIFORNIA, A PUBLIC HEARING WILL BE HELD WHERE THIS BOARD WILL CONSIDER THE ESTABLISHMENT OF THE PROPOSED CFD NO. 2017-1, THE RATE AND METHOD OF APPORTIONMENT OF THE SPECIAL TAX PROPOSED TO BE LEVIED WITHIN CFD NO. 2017-1, AND ALL OTHER MATTERS AS SET FORTH IN THIS RESOLUTION OF INTENTION. AT THE ABOVE-MENTIONED TIME AND PLACE FOR PUBLIC HEARING ANY PERSONS INTERESTED, INCLUDING TAXPAYERS AND PROPERTY OWNERS MAY APPEAR AND BE HEARD. THE TESTIMONY OF ALL INTERESTED PERSONS FOR OR AGAINST THE ESTABLISHMENT OF CFD NO. 2017-1, THE EXTENT OF CFD NO. 2017-1 OR THE FINANCING OF THE DEFEASANCE AND DISCHARGE, WILL BE HEARD AND CONSIDERED. ANY PROTESTS MAY BE MADE ORALLY OR IN WRITING, HOWEVER, ANY PROTESTS PERTAINING TO THE REGULARITY OR SUFFICIENCY OF THE PROCEEDINGS SHALL BE IN WRITING AND CLEARLY SET FORTH THE IRREGULARITIES AND DEFECTS TO WHICH THE OBJECTION IS MADE. ALL WRITTEN PROTESTS SHALL BE FILED WITH THE SECRETARY OF THE BOARD OF DIRECTORS OF THE DISTRICT ON OR BEFORE THE TIME FIXED FOR THE PUBLIC



HEARING. WRITTEN PROTESTS MAY BE WITHDRAWN IN WRITING AT ANY TIME BEFORE THE CONCLUSION OF THE PUBLIC HEARING.

IF A WRITTEN MAJORITY PROTEST AGAINST THE ESTABLISHMENT OF CFD NO. 2017-1 IS FILED, THE PROCEEDINGS SHALL BE ABANDONED. IF SUCH MAJORITY PROTEST IS LIMITED TO CERTAIN FACILITIES OR PORTIONS OF THE SPECIAL TAX, THOSE FACILITIES OR THAT PORTION OF THE SPECIAL TAX SHALL BE ELIMINATED BY THE BOARD.

SECTION 8. Report. The officers of the District who shall be responsible for the Defeasance and Discharge shall study CFD No. 2017-1, and, at or before the time of the public hearing, file a report with the Board containing a brief description of the Defeasance and Discharge Plan which will in their opinion be required to adequately meet the needs of CFD No. 2017-1, and their estimate of the fair and reasonable cost of the Defeasance and Discharge, and the incidental expenses to be incurred in connection therewith. Such report shall include a description and an estimate of the cost of the Defeasance and Discharge proposed to be financed with the proceeds of the special taxes and sale of the bonds of CFD No. 2017-1. Such report shall be made a part of the record of the public hearing to be held pursuant to Section 7 hereof.

SECTION 9. Election. If, following the public hearing described in Section 7, the Board determines to establish CFD No. 2017-1 and proposes to levy a special tax within CFD No. 2017-1, the Board shall then submit the levy of the special taxes to the qualified electors of CFD No. 2017-1 pursuant to Government Code Section 53326 through 53327.5 and the applicable provisions of the California Elections Code. If at least twelve (12) persons, who need not necessarily be the same twelve (12) persons, have been registered to vote within CFD No. 2017-1 for each of the ninety (90) days preceding the close of the public hearing, the vote shall be by registered voters of CFD No. 2017-1, with each voter having one (1) vote. Otherwise, the vote shall be by the landowners of CFD No. 2017-1 who were the owners of record at the close of the subject hearing, with each such landowner or the authorized representative thereof, having one (1) vote for each acre or portion of an acre of land owned within CFD No. 2017-1.

SECTION 10. Notice. Notice of the time and place of the public hearing shall be given by the Secretary, or their designee, by causing the publication of a Notice of Public Hearing in the legally designated newspaper of general circulation, such publication pursuant to Section 6061 of the Government Code, with such publication to be completed at least seven (7) days prior to the date set for the public hearing.

SECTION 11. Reservation of Rights to Authorize Tender of Bonds The Board reserves to itself, in its capacity as the legislative body of CFD No. 2017-1 if formed, the right and authority to allow any interested owner of property within CFD No. 2017-1, subject to the provisions of Government Code Section 53344.1 and to such conditions as this Board may impose, and any applicable prepayment penalties as may be described in the bond indenture or comparable instrument or document, to tender to the General Manager, acting for and on behalf of CFD No. 2017-1, in full payment or part payment of any installment of the special taxes or the interest or

penalties thereon which may be due or delinquent, but for which a bill has been received, any bond or other obligation secured thereby, the bond or other obligation to be taken at par and credit to be given for the accrued interest shown thereby computed to the date of tender.

SECTION 12. Advances Of Funds Or Work-In-Kind. At any time either before or after the formation of CFD No. 2017-1, the Board may accept advances of funds or work-in-kind from any source, including, but not limited to, private persons or private entities and may provide, by resolution, for the use of those funds or that work-in-kind for any authorized purpose, including, but not limited to, paying any cost incurred by the District in creating CFD No. 2017-1. The District may enter into an agreement, by resolution, with the person or entity advancing the funds or work-in-kind, to repay all or a portion of the funds so advanced, or to reimburse the person or entity for the value, or cost, whichever is less, of the work-in-kind, as determined by the Board. No such agreement shall constitute a debt or liability of the District.

SECTION 13. Effective Date. This resolution shall be effective upon its adoption

ADOPTED, SIGNED AND APPROVED this \_\_\_\_ day of \_\_\_\_\_, 2017.

---

President of the Board of Directors of  
Borrego Water District

ATTEST:

---

Secretary of the Board of Directors of  
Borrego Water District

EXHIBIT A

RATE AND METHOD OF APPORTIONMENT FOR  
BORREGO WATER DISTRICT  
COMMUNITY FACILITIES DISTRICT NO. 2017-1

*[attach a copy of the Rate and Method for CFD No. 2017-1]*

61170.00001\29558873.3

**RATE AND METHOD OF APPORTIONMENT FOR  
BORREGO WATER DISTRICT  
COMMUNITY FACILITIES DISTRICT NO. 2017-1**

A Special Tax as hereinafter defined shall be levied on all Assessor's Parcels in Borrego Water District Community Facilities District No. 2017-1 ("CFD No. 2017-1") and collected each Fiscal Year commencing in Fiscal Year 2017-18, in an amount determined by the CFD Administrator of the Borrego Water District through the application of the Rate and Method of Apportionment as described below. All of the real property in CFD No. 2017-1, unless exempted by law or by the provisions hereof, shall be taxed for the purposes, to the extent and in the manner herein provided.

**A. DEFINITIONS**

The terms hereinafter set forth have the following meanings:

**"Acre" or "Acreage"** means the land area of an Assessor's Parcel as shown on an Assessor's Parcel Map, or if the land area is not shown on an Assessor's Parcel Map, the land area shown on the applicable final map, parcel map, condominium plan, or other recorded County parcel map. Lot size equals Acreage multiplied by 43,560.

**"Act"** means the Mello-Roos Community Facilities Act of 1982, as amended, being Chapter 2.5, Division 2 of Title 5 of the Government Code of the State of California.

**"Administrative Expenses"** means the following actual or reasonably estimated costs directly related to the administration of CFD No. 2017-1: the costs of computing the Special Taxes and preparing the annual Special Tax collection schedules (whether by the Water District or designee thereof or both); the costs of collecting the Special Taxes (whether by the County or otherwise); the costs of remitting the Special Taxes to the Fiscal Agent; the costs of the Fiscal Agent (including its legal counsel) in the discharge of the duties required of it under the Fiscal Agent Agreement; the costs to the Water District, CFD No. 2017-1 or any designee thereof of complying with arbitrage rebate requirements; the costs to the Water District, CFD No. 2017-1 or any designee thereof of complying with Water District, CFD No. 2017-1 or obligated persons disclosure requirements associated with applicable federal and state securities laws and of the Act; the costs associated with preparing Special Tax disclosure statements and responding to public inquiries regarding the Special Taxes; the costs of the Water District, CFD No. 2017-1 or any designee thereof related to an appeal of the Special Tax; the costs associated with the release of funds from any escrow account; and the Water District's annual administration fees, and third party expenses. Administrative Expenses shall also include amounts estimated or advanced by the Water District or CFD No. 2017-1 for any other administrative purposes of CFD No. 2017-1, including attorney's fees and other costs related to commencing and pursuing any foreclosure or other resolution of delinquent Special Taxes.

**"Assessor's Parcel"** means a lot or parcel shown in an Assessor's Parcel Map with an assigned Assessor's parcel number.

**"Assessor's Parcel Map"** means an official map of the Assessor of the County designating parcels by Assessor's parcel number.

**"Board"** means the Board of Directors of the Water District.

**"Bond Owner"** means (i) Considine Family Foundation, a Colorado nonprofit corporation, or (ii) a Related Party.

**"Bonds"** means any bonds or other debt (as defined in Section 53317(d) of the Act), whether in one or more series, issued by CFD No. 2017-1 under the Act.

**"CFD Administrator"** means an official of the Water District, or designee thereof, responsible for determining the Special Tax Requirement and providing for the levy and collection of the Special Taxes.

**"CFD No. 2017-1"** means Borrego Water District Community Facilities District No. 2017-1.

**"County"** means the County of San Diego.

**"Developed Property"** means, for each Fiscal Year, all Assessor's Parcels of Taxable Property for which a building permit for purposes of constructing a new residential or non-residential development has been issued by the County after January 1, 2017 and as of January 1 of the prior Fiscal Year.

**"Exempt Property"** means the geographic area identified as Exempt Property in Exhibit A herein.

**"Fiscal Agent"** means the fiscal agent under the Fiscal Agent Agreement.

**"Fiscal Agent Agreement"** means the fiscal agent agreement, indenture, resolution or other instrument pursuant to which Bonds are issued, as modified, amended and/or supplemented from time to time.

**"Fiscal Year"** means the period starting July 1 and ending on the following June 30.

**"Maximum Special Tax"** means the Maximum Special Tax, determined in accordance with Section C below, that can be levied in any Fiscal Year on any Assessor's Parcel.

**"Outstanding Bonds"** means all Bonds which are deemed to be outstanding under the Fiscal Agent Agreement.

**"Property Owner Association Property"** means, for each Fiscal Year, any property within the boundaries of CFD No. 2017-1 that was owned by a property owner association, including any master or sub-association, as of January 1 of the prior Fiscal Year.

**"Proportionately"** means, for Developed Property, that the ratio of the actual Special Tax levy to the Maximum Special Tax is equal for all Assessor's Parcels of Developed Property. For Undeveloped Property, "Proportionately" means that the ratio of the actual Special Tax levy per Acre to the Maximum Special Tax per Acre is equal for all Assessor's Parcels of Undeveloped Property.

**"Public Property"** means, for each Fiscal Year, any property within CFD No. 2017-1 that is owned by, irrevocably offered for dedication to, or dedicated to the federal government, the State, the County, the Water District or any other public agency as of June 30 of the prior Fiscal Year; provided however that any property leased by a public agency to a private entity and subject to taxation under Section 53340.1 of the Act shall be taxed and classified in accordance with its use. To ensure that property is classified as Public Property in the first Fiscal Year after it is acquired by, irrevocably offered for dedication to, or dedicated to a public agency, the property owner shall notify the CFD Administrator in writing of such acquisition, offer, or dedication not later than June 30 of the Fiscal Year in which the acquisition, offer, or dedication occurred.

**"Related Party"** means any person or entity in which Terry Considine and/or Betsy Considine has direct or indirect control over.

**"Special Tax(es)"** means the special tax(es) to be levied in each Fiscal Year on each Assessor's Parcel of Taxable Property to fund the Special Tax Requirement.

**"Special Tax Requirement following sale of Bonds to a Third Party"** means that amount required in any Fiscal Year for CFD No. 2017-1 to: (i) pay debt service on all Outstanding Bonds; (ii) pay periodic costs on the Bonds, including but not limited to, credit enhancement and rebate payments on the Bonds; (iii) pay Administrative Expenses; (iv) pay any amounts required to establish or replenish any reserve funds for all Outstanding Bonds; (v) pay for reasonably anticipated delinquent Special Taxes based on the delinquency rate for Special Taxes levied in the previous Fiscal Year; less (vi) a credit for funds available to reduce the annual Special Tax levy, as determined by the CFD Administrator pursuant to the Fiscal Agent Agreement.

**"Special Tax Requirement for Bonds held by Bond Owner"** means that amount required in any Fiscal Year for CFD No. 2017-1 to: (i) pay debt service on all Outstanding Bonds; (ii) pay periodic costs on the Bonds, including but not limited to, credit enhancement and rebate payments on the Bonds; (iii) pay Administrative Expenses; less (iv) a credit for funds available to reduce the annual Special Tax levy, as determined by the CFD Administrator pursuant to the Fiscal Agent Agreement.

**"State"** means the State of California.

**"Taxable Property"** means all of the Assessor's Parcels within the boundaries of CFD No. 2017-1 which are not exempt from the Special Tax pursuant to law or Section E below.

**"Third Party"** means an entity other than the Bond Owner.

"**Undeveloped Property**" means, for each Fiscal Year, all Taxable Property not classified as Developed Property.

"**Water District**" means the Borrego Water District.

**B. ASSIGNMENT TO LAND USE CATEGORIES**

Each Fiscal Year, commencing Fiscal Year 2017-18, all Taxable Property within CFD No. 2017-1 shall be classified as Developed Property or Undeveloped Property, and shall be subject to Special Taxes in accordance with the rate and method of apportionment determined pursuant to Sections C and D below.

**C. MAXIMUM SPECIAL TAX**

**1. Developed Property**

The Maximum Special Tax for each Assessor's Parcel classified as Developed Property shall be equal to \$740 per Acre.

**2. Undeveloped Property**

The Maximum Special Tax for Undeveloped Property in CFD No. 2017-1 shall equal \$740 per Acre.

**D. METHOD OF APPORTIONMENT OF THE SPECIAL TAX**

For each Fiscal Year, commencing Fiscal Year 2017-18, if Bonds have been sold to a Third Party, then the Board shall determine the Special Tax Requirement following sale of Bonds to a Third Party and shall levy the Special Tax as described below. If Bonds have not yet been sold to a Third Party, then the Board shall determine the Special Tax Requirement for Bonds held by Bond Owner and shall levy the Special Tax as described below.

First: The Special Tax shall be levied Proportionately on each Assessor's Parcel of Developed Property at up to 100% of the applicable Maximum Special Tax; and

Second: If additional monies are needed to satisfy the Special Tax Requirement after the first step has been completed, the Special Tax shall be levied Proportionately on each Assessor's Parcel of Undeveloped Property at up to 100% of the Maximum Special Tax for Undeveloped Property.

Notwithstanding the above, under no circumstances will the Special Tax levied in a Fiscal Year against any Assessor's Parcel of Developed Property for which an occupancy permit for private residential use has been issued be increased by more than ten percent (10%) above the amount that would have been levied in that Fiscal Year as a consequence of delinquency or default by the owner of any other Assessor's Parcel within CFD No. 2017-1. To the extent that the levy of the Special Tax on residential property is limited by the provision in the

previous sentence, the levy of the Special Tax on all other Assessor's Parcels shall continue in equal percentages at up to 100% of the Maximum Special Tax.

**E. EXEMPTIONS**

No Special Tax shall be levied on the Exempt Property identified in Exhibit A.

In addition, no Special Tax shall be levied on Property Owner Association Property and Public Property.

**F. APPEALS AND INTERPRETATIONS**

Any property owner claiming that the amount or application of the Special Tax with respect to his or her Assessor's Parcel is not correct and requesting a refund may file a written notice of appeal and refund to that effect with the CFD Administrator not later than one calendar year after having paid the Special Tax that is disputed. The CFD Administrator shall promptly review the appeal, and if necessary, meet with the property owner, consider written and oral evidence regarding the amount of the Special Tax, and decide the appeal. If the CFD Administrator's decision requires the Special Tax be modified or changed in favor of the property owner, a cash refund shall not be made (except for the last year of levy), but an adjustment shall be made to the next Special Tax levy. Any dispute over the decision of the CFD Administrator shall be referred to the Board and the decision of the Board shall be final.

This procedure shall be exclusive and its exhaustion by any property owner shall be a condition precedent to any legal action by such owner.

Interpretations may be made by the Board by ordinance or resolution for purposes of clarifying any vagueness or ambiguity in this Rate and Method of Apportionment.

**G. MANNER OF COLLECTION**

The Special Tax will be collected in the same manner and at the same time as ordinary *ad valorem* property taxes; provided, however, that CFD No. 2017-1 may directly bill the Special Tax, may collect Special Taxes at a different time or in a different manner if necessary to meet its financial obligations, and may covenant to foreclose and may actually foreclose on delinquent Assessor's Parcels as permitted by the Act.

**H. PREPAYMENT OF SPECIAL TAX**

The following definition applies to this Section H:

**"Bond Redemption Date"** means the redemption date pursuant to the Fiscal Agent Agreement for the Outstanding Bonds to be redeemed with the prepayment.

**"Outstanding Bonds"** means all Previously Issued Bonds which are deemed to be outstanding under the Fiscal Agent Agreement after the first interest and/or principal payment date following the current Fiscal Year.



**"Previously Issued Bonds"** means all Bonds that have been issued by CFD No. 2017-1 prior to the date of prepayment.

**1. Prepayment in Full**

The obligation of an Assessor's Parcel of Developed Property or Undeveloped Property to pay the Special Tax may be prepaid and permanently satisfied as described herein; provided that (i) Bonds have been issued and (ii) there are no delinquent Special Taxes with respect to such Assessor's Parcel at the time of prepayment. An owner of an Assessor's Parcel intending to prepay the Special Tax obligation shall provide the CFD Administrator with written notice of intent to prepay. Within 30 days of receipt of such written notice, the CFD Administrator shall notify such owner of the prepayment amount for such Assessor's Parcel. The CFD Administrator may charge a reasonable fee for providing this service.

The Prepayment Amount (defined below) shall be calculated as summarized below (capitalized terms as defined below):

	Bond Redemption Amount
plus	Redemption Premium
plus	Defeasance Amount
plus	Administrative Fees and Expenses
less	<u>Reserve Fund Credit</u>
Total: equals	Prepayment Amount

As of the proposed date of prepayment, the Prepayment Amount (defined below) shall be calculated as follows:

**Step No.:**

1. Confirm that no Special Tax delinquencies apply to such Assessor's Parcel.
2. Compute the Maximum Special Tax applicable for the Assessor's Parcel to be prepaid.
3. Divide the Maximum Special Tax, computed pursuant to paragraph 2, by the total estimated Maximum Special Taxes for the entire CFD No. 2017-1 based on the Maximum Special Taxes which could be charged in the current Fiscal Year in CFD No. 2017-1.
4. Multiply the quotient computed pursuant to paragraph 3 by the Outstanding Bonds to compute the amount of Outstanding Bonds to be retired and prepaid (the "Bond Redemption Amount").

5. Multiply the Bond Redemption Amount computed pursuant to paragraph 4 by the applicable redemption premium, if any, as set forth in the Fiscal Agent Agreement, on the Outstanding Bonds to be redeemed (the "Redemption Premium").
6. Compute the amount needed to pay interest on the Bond Redemption Amount from the first bond interest and/or principal payment date following the current Fiscal Year until the Bond Redemption Date.
7. Determine the Special Taxes levied on the Assessor's Parcel in the current Fiscal Year which have not yet been paid.
8. Compute the minimum amount the CFD Administrator reasonably expects to derive from the reinvestment of the Prepayment Amount (as defined below) less the Administrative Fees and Expenses (as defined below) from the date of prepayment until the Bond Redemption Date.
9. Add the amounts computed pursuant to paragraphs 6 and 7 and subtract the amount computed pursuant to paragraph 8 (the "Defeasance Amount").
10. Verify the administrative fees and expenses of CFD No. 2017-1, including the costs of computation of the prepayment, the costs to invest the prepayment proceeds, the costs of redeeming Bonds, and the costs of recording any notices to evidence the prepayment and the redemption (the "Administrative Fees and Expenses").
11. If reserve funds for the Outstanding Bonds, if any, are at or above 100% of the reserve requirement (as defined in the Fiscal Agent Agreement) on the prepayment date, a reserve fund credit shall be calculated based on a reduction in the applicable reserve fund for the Outstanding Bonds, as set forth in the Fiscal Agent Agreement, to be redeemed pursuant to the prepayment (the "Reserve Fund Credit"). No Reserve Fund Credit shall be granted if reserve funds are below 100% of the reserve requirement.
12. The Special Tax prepayment is equal to the sum of the amounts computed pursuant to paragraphs 4, 5, 9 and 10, less the amount computed pursuant to paragraph 11 (the "Prepayment Amount").
13. From the Prepayment Amount, the amounts computed pursuant to paragraphs 4, 5, 9 and 11 shall be deposited into the appropriate fund as established under the Fiscal Agent Agreement and be used to retire Outstanding Bonds or make debt service payments. The amount computed pursuant to paragraph 10 shall be retained by CFD No. 2017-1.

The Prepayment Amount may be sufficient to redeem other than a \$5,000 increment of Bonds. In such cases, the increment above \$5,000 or integral multiple thereof will be retained in the appropriate fund established under the Fiscal Agent Agreement to be used with the next prepayment of Bonds or to make debt service payments.

As a result of the payment of the current Fiscal Year's Special Tax levy as determined under paragraph 7 (above), the CFD Administrator shall remove the current Fiscal Year's Special Tax levy for such Assessor's Parcel from the County tax rolls. With respect to any Assessor's Parcel that is prepaid, the Board shall cause a suitable notice to be recorded in compliance with the Act, to indicate the prepayment of Special Taxes and the release of the Special Tax lien on such Assessor's Parcel, and the obligation of such Assessor's Parcel to pay the Special Tax shall cease.

Notwithstanding the foregoing, no Special Tax prepayment shall be allowed unless the amount of Maximum Special Taxes that may be levied on all property in CFD No. 2017-1, both prior to and after the proposed prepayment, less expected Administrative Expenses, is at least 1.1 times the maximum annual debt service on all Outstanding Bonds.

## **2. Prepayment in Part**

The Special Tax on an Assessor's Parcel located in CFD No. 2017-1 may be partially prepaid. The amount of the prepayment shall be calculated as in Section H.1; except that a partial prepayment shall be calculated according to the following formula:

$$PP = (P_E - A) \times F + A$$

These terms have the following meaning:

- PP = the partial prepayment
- P<sub>E</sub> = the Prepayment Amount calculated according to Section H.1
- F = the percentage by which the owner of the Assessor's Parcel(s) is partially prepaying the Special Tax.
- A = the Administration Fees and Expenses from Section H.1

The owner of any Assessor's Parcel who desires such prepayment shall notify the CFD Administrator of such owner's intent to partially prepay the Special Tax and the percentage by which the Special Tax shall be prepaid. The CFD Administrator shall provide the owner with a statement of the amount required for the partial prepayment of the Special Tax for an Assessor's Parcel within thirty (30) days of the request and may charge a reasonable fee for providing this service. With respect to any Assessor's Parcel that is partially prepaid, the Water District shall (i) distribute the funds remitted to it according to Section H.1, and (ii) indicate in the records of CFD No. 2017-1 that there has been a partial prepayment of the Special Tax and that a portion of the Special Tax with respect to such Assessor's Parcel, equal to the outstanding percentage (1.00 - F) of the remaining Maximum Special Tax, shall continue to be levied on such Assessor's Parcel pursuant to Section D.

Notwithstanding the foregoing, no Special Tax prepayment shall be allowed unless the amount of Maximum Special Taxes that may be levied all property in CFD No. 2017-1, both prior to and after the proposed prepayment, less expected Administrative Expenses, is at least 1.1 times the maximum annual debt service on all Outstanding Bonds.

**I. TERM OF SPECIAL TAX**

The Special Tax shall be levied for a period not to exceed forty years commencing in Fiscal Year 2017-18.

**EXHIBIT A**

EXEMPT LOTS WITHIN THE  
 PROPOSED BOUNDARIES OF  
 BORREGO WATER DISTRICT  
 COMMUNITY FACILITIES DISTRICT NO. 2017-1  
 COUNTY OF SAN DIEGO  
 STATE OF CALIFORNIA

LEGEND

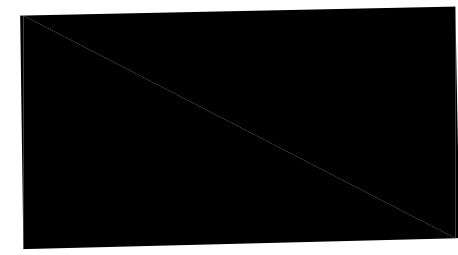
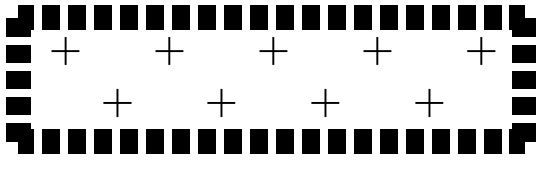
 Exempt Lots within the Proposed Boundaries of Borrego Water District Community Facilities District No. 2017-1, San Diego County, State of California  
 Area within C.F.D. Boundary

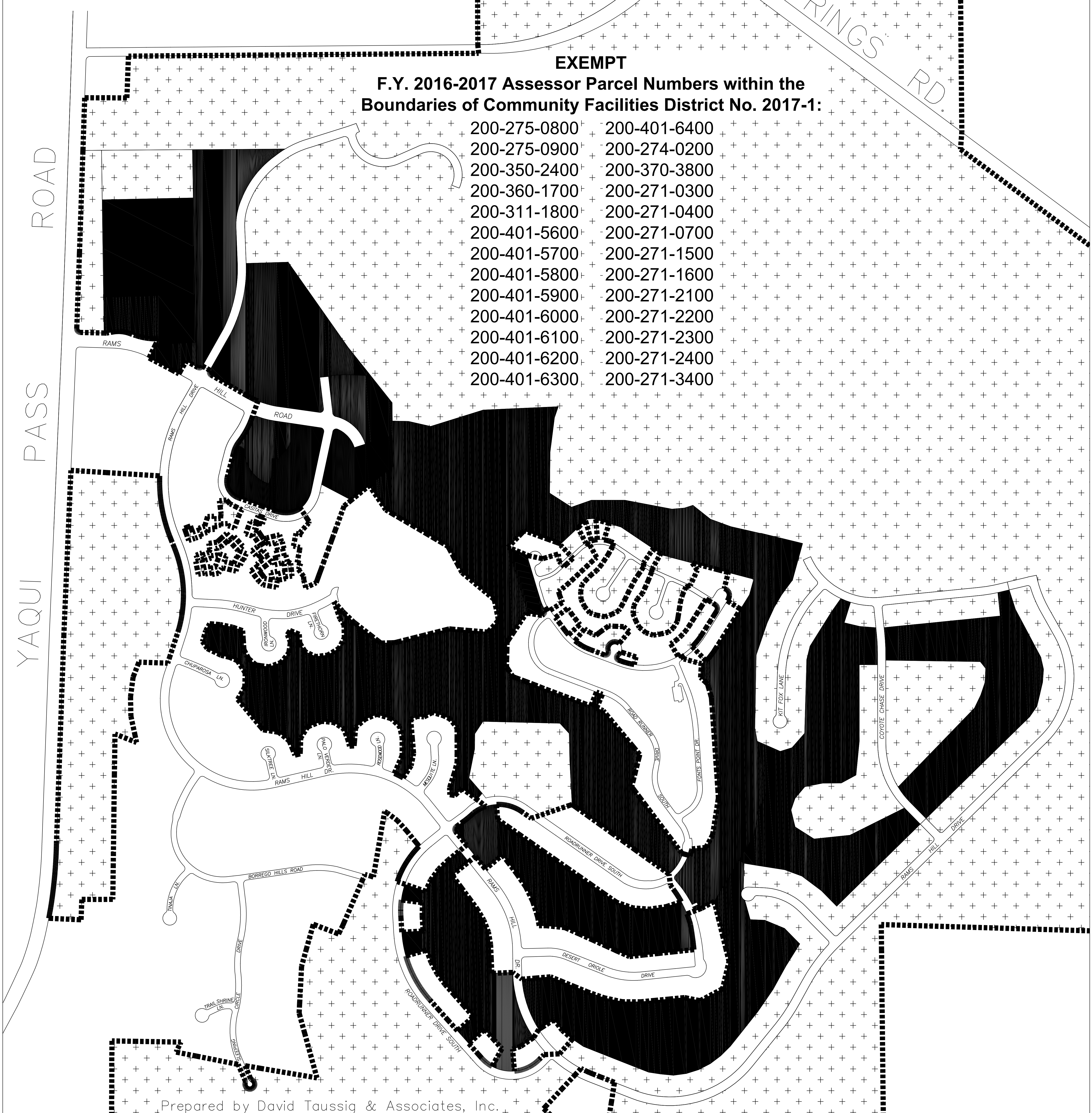
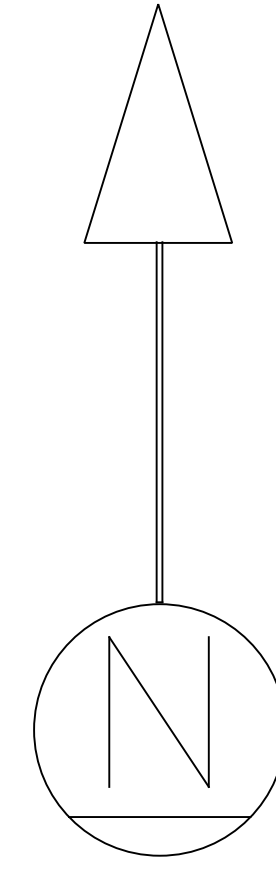

**EXEMPT  
 F.Y. 2016-2017 Assessor Parcel Numbers within the  
 Boundaries of Community Facilities District No. 2017-1:**

- |              |              |
|--------------|--------------|
| 200-275-0800 | 200-401-6400 |
| 200-275-0900 | 200-274-0200 |
| 200-350-2400 | 200-370-3800 |
| 200-360-1700 | 200-271-0300 |
| 200-311-1800 | 200-271-0400 |
| 200-401-5600 | 200-271-0700 |
| 200-401-5700 | 200-271-1500 |
| 200-401-5800 | 200-271-1600 |
| 200-401-5900 | 200-271-2100 |
| 200-401-6000 | 200-271-2200 |
| 200-401-6100 | 200-271-2300 |
| 200-401-6200 | 200-271-2400 |
| 200-401-6300 | 200-271-3400 |

RESOLUTION NO. 2017-03-04

RESOLUTION OF THE BOARD OF DIRECTORS OF THE BORREGO WATER DISTRICT DECLARING THE NECESSITY TO INCUR A BONDED INDEBTEDNESS FOR COMMUNITY FACILITIES DISTRICT NO. 2017-1 TO BE SECURED BY SPECIAL TAXES LEVIED THEREIN

WHEREAS, the Board of Directors (the "Board") of the Borrego Water District (the "District"), has initiated proceedings to create a community facilities district pursuant to the terms and provisions of the "Mello-Roos Community Facilities Act of 1982", being Chapter 2.5, Part 1, Division 2, Title 5 of the Government Code of the State of California (the "Act") to finance the defeasance and discharge of the obligation to pay a portion of the principal of and certain accrued and unpaid interest on the Borrego Water District Community Facilities District No. 2007-1 (Montesoro) Series 2007 Special Tax Bonds (the "Defeasance and Discharge"). This Community Facilities District shall hereinafter be referred to as Borrego Water District Community Facilities District No. 2017-1 (CFD No. 2017-1); and

WHEREAS, it is the intention of this legislative body to finance the Defeasance and Discharge through the issuance of bonds by CFD No. 2017-1, such bonds to be secured by special taxes to be levied on taxable property within CFD No. 2017-1, all as authorized pursuant to the Act.

NOW THEREFORE IT IS HEREBY RESOLVED:

SECTION 1. Recitals. The above recitals are all true and correct.

SECTION 2. Declaration of Convenience and Necessity. This City Council declares that the public convenience and necessity requires that a bonded indebtedness be incurred by CFD No. 2017-1 to contribute to the financing of all or a portion of the Defeasance and Discharge.

SECTION 3. Purpose for Proposed Indebtedness. The purpose for the proposed debt of CFD No. 2017-1 is to contribute to the financing of the Defeasance and Discharge.

SECTION 4. Bond Authorization. The amount of the bonded indebtedness of CFD No. 2017-1 may include all costs and estimated costs incidental to, or connected with, the accomplishment of the purpose for which the indebtedness is proposed to be incurred as authorized pursuant to the Act. The amount of the indebtedness proposed to be authorized for CFD No. 2017-1 shall not exceed \$10,500,000.

SECTION 5. NOTICE IS GIVEN THAT ON APRIL 18, 2017, AT THE HOUR OF 9:00 A.M. IN THE REGULAR MEETING PLACE OF THE LEGISLATIVE BODY, BEING 806 PALM CANYON DRIVE, BORREGO SPRINGS, CALIFORNIA, A HEARING WILL BE HELD ON THE INTENTION OF THIS LEGISLATIVE BODY TO INCUR A BONDED INDEBTEDNESS OF CFD NO. 2017-1 TO CONTRIBUTE TO THE FINANCING OF THE DEFEASANCE AND DISCHARGE, SUCH INDEBTEDNESS TO BE SECURED BY THE

LEVY OF SPECIAL TAXES WITHIN CFD NO. 2017-1. AT THE TIME AND PLACE FIXED FOR SAID PUBLIC HEARING ANY PERSONS INTERESTED, INCLUDING PERSONS OWNING PROPERTY WITHIN CFD NO. 2017-1, MAY APPEAR AND PRESENT ANY MATTERS RELATING TO THE PROPOSED INTENTION AND NECESSITY FOR INCURRING A BONDED INDEBTEDNESS OF CFD NO. 2017-1, SUCH INDEBTEDNESS WHICH WILL CONTRIBUTE TO THE FINANCING OF ALL OR A PORTION OF THE DEFEASANCE AND DISCHARGE AND WHICH WILL BE SECURED BY A SPECIAL TAX TO BE LEVIED WITHIN CFD NO. 2017-1.

SECTION 6. Notice of the time and place of the public hearing shall be given by the Board Secretary, or their designee, by publishing a Notice of Public Hearing in a legally designated newspaper of general circulation, said publication pursuant to Section 6061 of the Government Code, with said publication to be completed at least seven (7) days prior to the date set for the public hearing.

SECTION 13. Effective Date. This resolution shall be effective upon its adoption

ADOPTED, SIGNED AND APPROVED this \_\_\_\_\_ day of \_\_\_\_\_, 2017.

---

President of the Board of Directors of  
Borrego Water District

ATTEST:

---

Secretary of the Board of Directors of  
Borrego Water District

61170.00001\29558876.3



BORREGO WATER DISTRICT  
BOARD OF DIRECTORS MEETING – MARCH 14, 2017  
AGENDA BILL II.B

March 8, 2017

TO: Board of Directors, Borrego Water District  
FROM: Geoff Poole, General Manager  
SUBJECT: Plans and Specifications for 900 Tank Project – D Dale

**RECOMMENDED ACTION:** Approve Plans and Specifications for 900 Tank and authorize staff to publish and begin bidding process.

**ITEM DESCRIPTION:** District Engineer David Dale has been working on the various Engineering and Environmental documents needed for construction of the planned 900 tank. One of the last phases of this process is development of the Plans and Specifications.

David has completed the attached documents and Staff and the Operations and Infrastructure Committee recommend approval and authorization for BWD to begin the bidding process. The documents have also been reviewed by BWD Legal Counsel and ACWA/JPIA.

**FISCAL IMPACT:** To be determined after bidding process.

**ATTACHMENTS:**

1. Plans/Specifications and Drawings
2. Memorandum from Legal Counsel. Morgan Foley's comments will be incorporated into the Final Draft of the Specifications. Staff is recommending approval of the Plans/Specs as amended by Legal Counsel.

# **BORREGO WATER DISTRICT**

## **REQUEST FOR PROPOSAL**

### **900 Tank Replacement Project**

**March 2017**



## TABLE OF CONTENTS

### BORREGO WATER DISTRICT

### TABLE OF CONTENTS

Title Section	Page Number
Request for Proposals	1-3
Required Documents	4
Proposal Requirements	5-6
<b>Proposal Form</b>	7-9
Performance Bond	10
Labor and Material Bond	11
Workers' Compensation Insurance Certification	12
Subcontractor's Listing	13
Corporate Certification or Partnership Information	14
Contractor's Certification of Qualification for License Classification	15
General Conditions	16-41
Special Provisions	42-48
Technical Specifications	49-101
Project Vicinity Map	102
Project Plans	103

## **BORREGO WATER DISTRICT REQUEST FOR PROPOSAL**

### **BORREGO WATER DISTRICT - 900 TANK REPLACEMENT**

#### **1. GENERAL INFORMATION**

The BORREGO WATER DISTRICT (“the DISTRICT”) is requesting proposals for the BORREGO WATER DISTRICT - 900 TANK REPLACEMENT.

#### **2. SCOPE OF WORK**

The purpose of this project is the replacement of the 900 Tank. The existing tank is 24 feet tall with a diameter of 41 feet. The tank is bolted steel, and stores potable water. It is currently dry and ready to be demolished.

The project includes demolishing the existing 220,000 gallon capacity bolted steel tank, preparing the tank pad, installing a new 700,000 gallon capacity (nominal) bolted steel tank and connecting the existing piping to the new tank.

Eleven months after the substantial completion of the tank, the tank will be drained and an inspection will occur. Any areas of corrosion will be repaired by the Contractor as warranty work.

#### **3. PROJECT SCHEDULE**

To be completed within **one hundred (150) calendar days** from date of contract award.

#### **4. PROPOSAL REQUIREMENTS**

SEALED PROPOSALS will be accepted at the Office of the Borrego Water District, located at 806 Palm Canyon Drive, Borrego Springs, California 92004 until 2:00 p.m. on Thursday, **March 23, 2017**, at which time all proposals will be publicly opened and read aloud.

Each proposal must be submitted in a sealed envelope bearing on the outside the name of the proposer, his/her address and the name of the project for which the proposal is submitted. If forwarded by mail, the sealed envelope containing the proposal must be enclosed in another envelope addressed as specified in the proposal form.

No proposal will be received unless it is made on the prescribed proposal form furnished by the General Manager.

In addition to the required documents listed on page 4, the proposal may be considered incomplete and be disqualified if any of the following information is not provided.

1. Proposal Form
2. Workers' Compensation Certificate

3. Subcontractor's listing: If no subcontractor will be used, indicate an "X" mark on the space provided for "No subcontractor."
4. Corporate Certification or Partnership Information
5. Contractor's Certification of Qualification for License Classification
6. Provide company experience relevant to this project in the last five years.

**LICENSE CLASSIFICATION:** All proposers shall be licensed under the provisions of Chapter 9, Division 3 of the Business and Professions Code of the State of California to do the type of work contemplated in the project. In accordance with provisions of California Public Contract Code §3300, the DISTRICT has determined that the Contractor shall possess a valid **Class A (General)** license at the time that the proposal is submitted. Failure to possess the specified license(s) shall render the proposal as non-responsive.

Pursuant to Section 1773 of the Labor Code, the general prevailing rate of wages in the County in which the work is to be done has been determined by the Director of the California Department of Industrial Relations. These wages are also available from the California Department of Industrial Relations' Internet web site at <http://www.dir.ca.gov>. Future effective general prevailing wage rates, which have been predetermined and are on file with the California Department of Industrial Relations are referenced but not printed in the general prevailing wage rates.

**THE DISTRICT'S RIGHT RESERVED:** The DISTRICT reserves the right to reject any or all proposals, to waive any informality in a proposal, and to make awards in the interest of the DISTRICT.

END OF REQUEST FOR PROPOSALS

## **REQUIRED DOCUMENTS**

**The following is a list of documents to be submitted as part of the proposal packet. Proposals not containing the following documents could be considered incomplete and are subject to rejection.**

- Proposal Form
- Workers' Compensation Certificate
- Subcontractor's Listing
- Corporate Certification or Partnership Information
- Contractor's Certification of Qualification for License Classification
- Proposing Firm's relevant experience within five years

## PROPOSAL REQUIREMENTS

1. Examination of Plans, Specifications, Special Provisions and Site of Work: The proposer is required to examine carefully the site of work contemplated and it will be assumed that the proposer has investigated and is satisfied as to the conditions to be encountered, as to the character, quality and quantities of work to be performed and materials to be furnished and as to the requirements of the specifications, special provisions and the contract. It is mutually agreed that submission of a proposal shall be considered prima facie evidence that the proposer has made such examination.
2. Proposal Form: All proposals must be made on the proposal forms to be obtained from the Borrego Water District, California and contained herein. All proposals must give the prices proposed both in figures and must be signed by the proposer with proposer's business address.

If the proposal is made by an individual, the individual's name and post office address must be shown. If made by a firm or partnership, the name and post office address of each member of the firm or partnership must be shown. If made by a corporation, the proposal must show the name of the State under the laws of which the corporation is chartered and the name, titles and business addresses of the President, Secretary and Treasurer. A certification by the legal representative of the firm must be included in the proposal.

3. Rejection of Proposal Containing Alterations, Erasures or Irregularities: Proposals may be rejected if they show any alterations of form additions not called for, conditional or alternative proposals, incomplete proposals, erasures or irregularities of any kind.
4. Award of Contract: The award of the contract, if it is awarded, will be to the proposer whose proposal best meets the District's needs. The award, if made, will be made within sixty (60) calendar days after the opening of the proposals. All proposals will be compared on the basis of the General Manager estimate of quantities of work to be done.
5. Removal of Defective and Unauthorized Work: All work which is defective in its construction or deficient in any of the requirements of these specifications, special provisions or plans shall be remedied or removed and replaced by the Contractor in an acceptable manner and no compensation will be allowed for such correction. Any work done beyond the lines and grades shown on the plans or established by the General Manager, or any extra work done without written authority will be considered as unauthorized and will not be paid for.
6. Upon failure on the part of the Contractor to comply with any order of the General Manager made under these provisions, the General Manager shall be the authority to cause defective work to be removed and to deduct the costs thereof from any monies due or to become due to the Contractor.

7. Final Inspection: Whenever the work provided and contemplated by the contract shall have been satisfactorily completed and the final clean up performed, the General Manager will make the final inspection at the site.
8. Amount of Bonds: The faithful performance bond shall be in the sum of not less than one hundred percent (100%) of the contract price.

The bond for material men and laborers shall be in an amount equal to not less than one hundred percent (100%) of the contract price. Form of bond required can be examined at the office of the General Manager; copies will be furnished, if desired, to prospective proposers.

Payment and performance bonds shall be executed by a California-admitted surety insurer with a minimum Best's Insurance Guide rating of A+, Class VII.

Whenever any surety or sureties on any such bond, or on any bonds required by law for the protection of the claims of laborers and material men, become insufficient or the DISTRICT Board has cause to believe that such surety or sureties have become insufficient, a demand in writing may be made of the Contractor for such further bond or bonds or additional surety, not exceeding that originally required, as is considered necessary, considering the extent of the work remaining to be done. Thereafter, no payment shall be made upon such contract to the Contractor or any assignee of the Contractor until such further bond or bonds or additional surety has been furnished.

9. Compliance with Laws and Regulations: No proposal for work will be accepted from a Contractor who is not licensed in accordance with the law under the provisions of Chapter 9 of Division III, of the Business and Professions Code of the State of California, as amended. The Contractor awarded the contract shall also submit the Contractor's Certification of Qualifications for License Classification contained in these contract documents along with the submission of the executed contract and acceptable sureties. All proposals submitted and all contracts awarded hereunder must be submitted, filed, made and executed in accordance with all applicable laws of the State of California and of the United States of America which relate to proposals and contracts of the nature referred to herein, whether such laws are expressly referred to herein or not.
10. **MINIMUM WAGES:** California State Prevailing Wages are required for this project.

Pursuant to the requirements of Senate Bill 854 and California Labor Code section 1725.5, all contractors and subcontractors that wish to engage in public work through a public works contract must first register with the Department of Industrial Relation and pay all applicable fees. Beginning March 1, 2015, no contractor or subcontractor may be listed on a bid proposal for a public works project unless registered with the Department of Industrial Relations, pursuant to Labor Code section 1725.5 (with limited exceptions from this requirement for bid purposes only under Labor Code section 1771.1(a)). Beginning April 1, 2015, no contractor or subcontractor may be awarded a contract for public work on a



public works project unless registered with the Department of Industrial Relations, pursuant to Labor Code section 1725.5 This Project is subject to compliance monitoring and enforcement by the Department of Industrial Relations. For more information concerning Senate Bill 854 compliance, please visit: <http://www.dir.ca.gov/PublicWorks/SB854.html>.

Pursuant to Section 1773 of the Labor Code, the general prevailing rate of wages in the County in which the work is to be done has been determined by the Director of the California Department of Industrial Relations. These wages are also available from the California Department of Industrial Relations' Internet web site at <http://www.dir.ca.gov>. Future effective general prevailing wage rates, which have been predetermined and are on file with the California Department of Industrial Relations are referenced but not printed in the general prevailing wage rates.

PREVAILING WAGE COMPLIANCE - CONTRACTOR and its subcontractors shall pay all workers employed on the project the rates determined by the Director of California Department of Industrial Relations ("DIR"). Copies of the State prevailing rate per diem wages are on file 16 with the Department of Industrial Relations, Division of Apprenticeship Standards 445 Golden Gate Ave, San Francisco, California and are available to the CONTRACTOR and any other interested party upon request. CONTRACTOR shall post the prevailing rate of per diem wages at the project site.

A. END OF PROPOSAL REQUIREMENTS

## PROPOSAL FORM

TO THE GENERAL MANAGER OF THE DISTRICT:

The undersigned hereby declares that they:

- 1.01 - have carefully examined the site of proposed construction;
- 1.02 - have read completely and understand the contract documents;
- 1.03 - have knowledge of the laws and regulations that will affect the work; and,
- 1.04 - have given notice to the DISTRICT Engineer of any errors, conflicts or discrepancies found in the contract documents.

The undersigned hereby proposes to furnish all labor, materials, equipment, services, supplies, surveying, testing and incidentals thereto required to construct complete and in accordance with the contract documents, of which this form is a part, the following items for the prices indicated:

### PROPOSAL FORM - 900 Tank Replacement

Item No.	Approximate Quantity	Unit	Items Unit Price (written in words)	Price/ Unit	Total Item Sum
1.	1	LS	Mobilization/ Demobilization, Temporary Facilities, Insurance, Payment Bond, Taxes, Permits, Fees and Similar Expenses		
2.	1	LS	Demolish existing bolted 220,000 gallon steel tank. Remove and dispose of the tank and grade ring.		
3.	1	LS	Provide tank submittal, signed and stamped by a registered engineer in the State of California. Payment after acceptance.		
4.	1	LS	Prepare Tank Pad – Excavate 30 inches of native material. Remove and dispose of existing piping located inside the new tank pad. Install and re-compact 22 inches of native material. Install 8-inch steel ring around the perimeter of the tank. Install 1-inch No. 4 Rock eight inches thick. Install 1/2" Fiber expansion joint material on top of the rock.		

5.	1	LS	Furnish and Install OSHA exterior locking ladder kit and railing around the roof hatch		
6.	1	LS	Install fusion powder coated bolted steel tank, nominal dimensions 16' high and 86' diameter. After installation, complete holiday testing of interior coating and repair all holidays to the satisfaction of the engineer.		
7.	1	LS	Install piping, resilient wedge gate valves, transition couplings, DI and steel fittings, Tideflex valve, expansion joints, DI blind flange, check valves, pipe supports, 10" flow meter (relocate existing), ductile iron risers, thrust blocks, anti-vortex hardware, and other appurtenances as necessary for a functional system and as shown on the plans. Connect to existing piping as shown.		
8.	1	LS	Hydrostatic and Pressure Testing, VOC Testing, Wash-down and Cleaning of the interior, Disinfection, and Bacteriological Testing. Water provided by the District at no charge.		

**Total Proposal** (consisting of the sum of items 1-9) is:

\$ \_\_\_\_\_ (numerals)

**Total Proposal** (consisting of the sum of items 1-9) is:

\$ \_\_\_\_\_ (written word)

The above proposal, submitted above by a qualified prospective proposer, both in numerical form and written in words, shall constitute the Total Proposal for this proposed project. The prospective proposer is responsible to place the amount proposal for each and every one of the above items in Base Proposal. Following receipt of sealed proposals, the DISTRICT shall numerically add the amounts proposal for all items in the proposal. The amount of the Total Proposal written in words shall be

interpreted as a confirmation of the intent of the prospective proposer in preparing the Total Proposal. The numerical sum of all proposal items in the Proposal as derived by the DISTRICT shall be considered the correct Total Proposal, in case an addition error has been made by the prospective proposer.

1.00 – The undersigned hereby certifies that this proposal is genuine and not made in the interest of or on behalf of any undisclosed person, firm or corporation.

2.00 – The undersigned hereby accepts on the behalf of his/her/its firm all provisions and requirements of the contract documents, including but not limited to those related to time of completion and liquidated damages.

3.00 – The undersigned hereby certifies that they are authorized representative of the firm on whose behalf this proposal/proposal is submitted and that they are acting at the direction and with the required approval of said firm, which is identified as follows:

Name of firm: \_\_\_\_\_

Address of firm: \_\_\_\_\_

Telephone ( ) \_\_\_\_\_ Fax ( ) \_\_\_\_\_  
Number: \_\_\_\_\_ Number: \_\_\_\_\_

Contractor's License \_\_\_\_\_ Type: \_\_\_\_\_

Number: \_\_\_\_\_

Signed: \_\_\_\_\_ Date: \_\_\_\_\_

**B. END OF PROPOSAL/PROPOSALFORM**

**PERFORMANCE BOND**

Whereas, The DISTRICT Board of directors, and \_\_\_\_\_ (hereinafter designated as "principal") have entered into an agreement whereby principal agrees to install and complete certain designated public improvements, which said agreement, dated \_\_\_\_\_, 20\_\_, and identified as project \_\_\_\_\_, is hereby referred to and made a part hereof; and

Whereas, Said principal is required under the terms of said agreement to furnish a bond for the faithful performance of said agreement.

Now, therefore, we, the principal and \_\_\_\_\_, as surety, are held and firmly bound unto the DISTRICT (hereinafter designated as "The district") in the penal sum of \_\_\_\_\_ dollars (\$\_\_\_\_\_) lawful money of the United States, for the payment of which sum well and truly to be made, we bind ourselves, our heirs, successors, executors and administrators, jointly and severally, firmly by these presents.

The condition of this obligation is such that if the above-bounded principal, his or its heirs, executors, administrators, successors or assigns, shall in all things stand to and a proposal by, and well and truly keep and perform the covenants, conditions and provisions in the said agreement and any alteration thereof made as therein provided, on his or their part, to be kept and performed at the time and in the manner therein specified, and in all respects according to their true intent and meaning, and shall indemnify and save harmless the district, its officers, agents and employees, as therein stipulated, then this obligation shall become null and void; otherwise it shall be and remain in full force and effect.

As a part of the obligation secured hereby and in addition to the face amount specified therefor, there shall be included costs and reasonable expenses and fees, including reasonable attorney's fees, incurred by The district in successfully enforcing such obligation, all to be taxed as costs and included in any judgment rendered.

The surety hereby stipulates and agrees that no change, extension of time, alteration or addition to the terms of the agreement or to the work to be performed thereunder or the specifications accompanying the same shall in anywise affect its obligations on this bond, and it does hereby waive notice of any such change, extension of time, alteration or addition to the terms of the agreement or to the work or to the specifications.

In Witness Whereof, this instrument has been duly executed by the principal and surety above named, on \_\_\_\_\_, 20\_\_.

\_\_\_\_\_  
PRINCIPAL

\_\_\_\_\_  
SURETY

BY \_\_\_\_\_  
ATTORNEY IN FACT

END OF FAITHFUL PERFORMANCE BOND

**LABOR AND MATERIAL BOND**

Whereas, The DISTRICT Board of the DISTRICT , State of California, and \_\_\_\_\_ (hereinafter designated as "the principal") have entered into an agreement whereby the principal agrees to install and complete certain designated public improvements, which agreement, dated \_\_\_\_\_, 20 \_\_\_\_, and identified as project \_\_\_\_\_, is hereby referred to and made a part hereof; and

Whereas, Under the terms of the agreement, the principal is required before entering upon the performance of the work, to file a good and sufficient payment bond with the DISTRICT to secure the claims to which reference is made in Title 15 (commencing with Section 3082) of Part 4 of Division 3 of the Civil Code of the State of California.

Now, therefore, the principal and the undersigned as corporate surety, are held firmly bound unto the DISTRICT and all contractors, subcontractors, laborers, materialmen, and other persons employed in the performance of the agreement and referred to in Title 15 (commencing with Section 3082) of Part 4 of Division 3 of the Civil Code in the sum of \_\_\_\_\_ dollars (\$ \_\_\_\_\_), for materials furnished or labor thereon of any kind, or for amounts due under the Unemployment Insurance Act with respect to this work or labor, that the surety will pay the same in an amount not exceeding the amount hereinabove set forth, and also in case suit is brought upon this bond, will pay, in addition to the face amount thereof, costs and reasonable expenses and fees, including reasonable attorney's fees, incurred by the DISTRICT in successfully enforcing this obligation, to be awarded and fixed by the court, and to be taxed as costs and to be included in the judgment therein rendered.

It is hereby expressly stipulated and agreed that this bond shall inure to the benefit of any and all persons, companies, and corporations entitled to file claims under Title 15 (commencing with Section 3082) of Part 4 of Division 3 of the Civil Code, so as to give a right of action to them or their assigns in any suit brought upon this bond.

Should the condition of this bond be fully performed, then this obligation shall become null and void, otherwise it shall be and remain in full force and effect.

The surety hereby stipulates and agrees that no change, extension of time, alteration or addition to the terms of the agreement or the specifications accompanying the same shall in any manner affect its obligations on this bond, and it does hereby waive notice of any such change, extension, alteration or addition.

In witness whereof, this instrument has been duly executed by the principal and surety above named, on \_\_\_\_\_, 20\_\_\_\_.

\_\_\_\_\_  
PRINCIPAL

\_\_\_\_\_  
SURETY

BY \_\_\_\_\_  
ATTORNEY IN FACT

END OF LABOR AND MATERIAL BOND

**II. WORKERS' COMPENSATION INSURANCE CERTIFICATE**

The Contractor shall execute the following form as required by the California Labor Code, Sections 1860 and 1861:

I am aware of the provisions of Section 3700 of the Labor Code which requires every employer to be insured against liability for workers' compensation or to undertake self-insurance in accordance with the provisions of that code, and I will comply with such provisions before commencing the performance of the work of this contract.

\_\_\_\_\_   
Date

\_\_\_\_\_   
Contractor's Name

\_\_\_\_\_   
Contractor's Signature

\_\_\_\_\_   
Title

ATTEST:

By \_\_\_\_\_   
Signature

\_\_\_\_\_   
Title

END OF WORKERS' COMPENSATION INSURANCE CERTIFICATE

### III. SUBCONTRACTORS LISTING

As required by Section 4100 of the Public Contract Code of the State of California, Contractor shall comply with the "Subletting and Subcontracting Fair Practices Act" of the State of California, and shall list all subcontractors required to be listed thereby.

DESCRIPTION OF WORK	DOLLAR AMOUNT OF WORK
(a) AM E	PLACE OF BUSINESS: ADDRESS/TELEPHONE No.
DESCRIPTION OF WORK	DOLLAR AMOUNT OF WORK
(b) AM E	PLACE OF BUSINESS: ADDRESS/TELEPHONE No.
DESCRIPTION OF WORK	DOLLAR AMOUNT OF WORK
(c) AM E	PLACE OF BUSINESS: ADDRESS/TELEPHONE No.
DESCRIPTION OF WORK	DOLLAR AMOUNT OF WORK
(d) AM E	PLACE OF BUSINESS: ADDRESS/TELEPHONE No.
DESCRIPTION OF WORK	DOLLAR AMOUNT OF WORK
(e) AM E	PLACE OF BUSINESS: ADDRESS/TELEPHONE No.

\*  No subcontractor will be used for this project.

\_\_\_\_\_ Date

\_\_\_\_\_ Contractor's Name

\_\_\_\_\_ Contractor's Signature

\_\_\_\_\_ Title

\*Indicate  if no subcontractor will be used.

END OF SUBCONTRACTORS LISTING



**CORPORATE CERTIFICATION  
OR  
PARTNERSHIP INFORMATION**

Name of Corporation or Partnership \_\_\_\_\_

\_\_\_\_\_

State of Incorporation \_\_\_\_\_

List names and addresses of each partner, or titles, names and business addresses of President, Secretary and Treasurer.

\_\_\_\_\_  
\_\_\_\_\_  
\_\_\_\_\_

Dated \_\_\_\_\_ Contractor \_\_\_\_\_

Signature \_\_\_\_\_ Title \_\_\_\_\_

ATTEST:

Signature by \_\_\_\_\_

Title \_\_\_\_\_

//  
//  
//

END OF CORPORATE CERTIFICATION

**CONTRACTOR'S CERTIFICATION OF QUALIFICATION  
FOR LICENSE CLASSIFICATION**

After award of the Contract, the Contractor, whether an individual, co-partnership, limited partnership, corporation, or any other combination or organization, shall execute the following form:

1. If an individual, I hereby certify that I am, or my responsible managing employee \_\_\_\_\_ (insert name) is, qualified for the license classification called for in these Contract Documents.
  
2. If a co-partnership or limited partnership, the general partner hereby certifies that the general partner \_\_\_\_\_ (insert name), or \_\_\_\_\_ responsible \_\_\_\_\_ managing \_\_\_\_\_ employee \_\_\_\_\_ (insert name), is qualified for the license classification called for in these Contract Documents.
  
3. If a corporation, or any other combination or organization, the responsible managing officer \_\_\_\_\_ (insert name), or a responsible managing employee \_\_\_\_\_ (insert name), is qualified for the license classification called for in these Contract Documents.

If the individual who qualifies the Contractor for the license classification called for in these Contract Documents changes during the progress of the work, then Contractor shall, within seven (7) days of any such change, notify the General Manager in writing of such change, including the name, license number and status of the individual.

For the purpose of this Certification, a responsible managing employee shall mean an individual who is a bona fide employee of the Contractor and is actively engaged in the classification of work for which that individual is the qualifying person on behalf of the Contractor under California law.

DATED: \_\_\_\_\_

CONTRACTOR: \_\_\_\_\_

SIGNATURE: \_\_\_\_\_

TITLE: \_\_\_\_\_

ATTEST:

SIGNATURE BY: \_\_\_\_\_

TITLE: \_\_\_\_\_

END OF CONTRACTOR'S CERTIFICATION OF QUALIFICATION FOR LICENSE  
CLASSIFICATION

## **GENERAL CONDITIONS**

### **1-01 DEFINITIONS.**

- a) The word "DISTRICT" shall mean the BORREGO WATER DISTRICT.
- b) The term "DISTRICT Board" shall mean the District Board of the Directors.
- c) The word "Contractor" shall mean the party of the second part entering into the Contract with the DISTRICT for the performance of work required by these specifications, and legal representatives of said party, or agent appointed to act for said party in the performance of the work. Said party is referred to throughout the contract documents as if of the singular number and the masculine gender.
- d) The word "General Manager" shall mean the DISTRICT's General Manager/DISTRICT Engineer, acting either directly or through properly authorized agents, such agents acting within the scope of the particular duties entrusted to them.
- e) The word Greenbook shall mean the Standard Specifications for Public Works Construction contained in the latest edition, as written and promulgated by the Joint Cooperative Committee of the Southern California Chapter of the American Public Works Association and the Southern California District of the Associated General Contractors of California. Copies of these Standard Specifications are available from the publisher, Building News, Incorporated, 1612 South Clementine Street, Anaheim, California, 92802, telephone (714) 517-0970

### **1-02 CONTRACT DOCUMENTS**

The Notice of Inviting Proposals, the Instructions to Proposers, the Proposal, the Specifications and the Drawings, together with the Contract and those documents specified in paragraph 12 of the "Special Provisions" constitute the Contract. These Contract Documents are complimentary, and what is called for in any one shall be as binding as if called for in all. The intention of the documents is to require a complete and finished piece of work. The Contractor at his sole cost and expense shall perform all labor and services and shall furnish all materials, tools, equipment and facilities necessary for the proper execution of the work, with the exception of such items as are definitely stipulated in the specifications or the drawings to be furnished by the DISTRICT. Anything shown in the drawings and not in the specifications or in the specifications and not in the drawings shall be performed by the Contractor as though shown in both the drawings and the specifications.

### **1-03 AUTHORITY OF THE GENERAL MANAGER**

The General Manager shall give all orders and directions contemplated under the Contract, shall determine the adequacy of the Contractor's methods, plans, and appurtenances, shall determine in all cases the amount, quality, acceptability and

fitness of the several kinds of work and materials which are to be paid for, shall determine all questions in relation to said work and the construction thereof and shall decide in all cases every question, which may arise relative to the fulfillment of this Contract on the part of the Contractor. Should any discrepancy appear or any misunderstandings arise as to the import of anything contained in the specifications or drawings, the matter shall be referred to the General Manager, who shall decide the same in accordance with the true intent and meaning as construed by him, and his decision shall be binding on the Contractor. Any differences or conflicts which may arise between the Contractor and other contractors of the DISTRICT in regard to their work shall be adjusted and determined by the General Manager.

#### 1-04 ACCESS TO WORK

The General Manager, his assistants, inspectors, agents and other employees shall at all times and for any purposes have access to the work and the premises used by the Contractor, and the Contractor shall provide safe and proper facilities therefore.

#### 1-06 LEGAL ADDRESS OF CONTRACTOR

The address given in the Contractor's proposal on which the Contract is founded is hereby designated as the place to which all notices, letters and other communications to the Contractor shall be mailed or delivered. The mailing to or delivering at the above-named place of any notice, letters or other communication to the Contractor shall be deemed sufficient service thereof upon the Contractor. The date of said service shall be the date of such mailing or delivery. Such address may be changed at any time by a written notice signed by the Contractor and delivered to the General Manager.

#### 1-07 CONTRACTOR'S RESPONSIBILITIES

- (a) The Contractor shall be responsible for safe, efficient and adequate methods and equipment during the progress of the work so as to secure the safety of the workers, the quality of work required and the stipulated rate of progress.
- (b) The Contractor shall bear all losses resulting to him on account of the amount of character of the work, or from any unforeseen obstructions or difficulties, which may be encountered, on account of the weather, floods or other causes.
- (c) The Contractor shall assume the defense of and indemnify and save harmless the DISTRICT and its officers and agents from all claims of any kind arising from his own negligence or that of his agents in the performance of the Contract.
- (d) The Contractor shall be responsible for any materials furnished him and for the care of all work until its completion and final acceptance, and he shall at his own expense replace damaged or lost material and repair damaged parts of the work, or the same may be done at his expense by the DISTRICT.

- (e) During the progress of the work the Contractor shall keep the premises occupied by him in a neat and clean condition and free from any unsightly accumulation of rubbish, unused material, concrete forms and other equipment and materials belonging to him or used under his direction during construction, and in the event of his failure to do so, the same may be removed by the DISTRICT at the expense of the Contractor.
- (f) Traffic Control. The Contractor shall be responsible for maintaining traffic control at all times under the guidelines of the State of California Manual and the Uniform Traffic Control. The Contractor shall submit two (2) traffic control plans for pre-approval by the General Manager a minimum of forty-eight (48) hours before starting construction work.

#### 1-08 CONTRACTOR TO FURNISH INFORMATION

- (a) Before proceeding with the erection of the construction plant, and other temporary structures, the Contractor shall furnish the General Manager with information and drawings of all such structures as may be required.
- (b) Drawings and prints in such detail as may be required, or articles, machinery or fabricated materials entering into permanent construction which are by these specifications required to be furnished by the Contractor and of which detailed drawings are not furnished by the DISTRICT shall be submitted by the Contractor for approval and shall become the property of the DISTRICT. Such approval shall not, however, operate to waive or modify any provision or requirement contained in these specifications.

#### 1-09 EXAMINATION OF WORK

Proposers must examine the location, physical conditions and surrounding of the proposed work and judge for themselves the nature of the excavations to be made and the work to be done.

The Contract Documents for the work show conditions as they are supposed or believed by the General Manager to exist, but it is not intended or to be inferred that the conditions as shown therein constitute a representation or warranty, express or implied, by the DISTRICT or any of its officers or employees, that such conditions are actually existent, nor shall the Contractor be relieved of the liability under the Contract, nor shall the DISTRICT or any of its officers or employees be liable for any loss sustained by the Contractor as a result of any variance between conditions shown in the Contract Documents and the actual conditions revealed during the progress of the work or otherwise.

## 1-10 PLANS AND DRAWINGS

All authorized alterations affecting the requirements and information given on the approved plans shall be in writing. No changes shall be made of any plan or drawing after the same has been approved by the General Manager, except by direction of the General Manager.

Deviations from the approved plans, as may be required by the exigencies of construction, will be determined in all cases by the General Manager and authorized in writing.

Working drawings or plans for any structure not included in the plans furnished by the General Manager shall be approved by the General Manager before any work involving these plans shall be performed, unless approval is waived in writing by the General Manager.

It is mutually agreed, however, that approval by the General Manager of the Contractor's working plans does not relieve the Contractor of any responsibility for accuracy of dimensions and details, and that the Contractor shall conform to the approved plans and specifications.

## 1-11 PERSONAL ATTENTION

The Contractor shall give his personal attention constantly to the faithful prosecution of the work, and shall be present, either in person or by a duly authorized and competent representative, on the site of the work, continually during its progress, to receive directions or instructions from the General Manager. Whenever the Contractor is not present on any part of the work where it may be desired to give directions, orders may be given by the General Manager, and shall be received and obeyed by the superintendent or foreman who may have charge of the particular part of the work in reference to which orders are given.

## 1-12 PROTESTS

If the Contractor considers any work demanded of him to be outside the requirements of the Contract, or if he considers any order or ruling of the General Manager or of any inspector to be unfair, he shall immediately upon such work being demanded or such order or ruling being made, ask for written instructions or decision, whereupon he shall proceed without delay to perform the work or conform to the order or ruling; but unless the Contractor finds such instructions or decision satisfactory, he shall, within ten (10) days after receipt of same, file a written protest with the General Manager, stating clearly and in detail his objections and the reason therefore. Except for such grounds of protest or objections as are made of record in the manner specified and within the time stated herein, the Contractor hereby waives all grounds for protests or objections to the orders, ruling, instructions or decisions of the General Manager, and hereby agrees that

as to all matters not included in such protests the orders, instructions and decisions of the General Manager shall be final and conclusive.

#### 1-13 RIGHT-OF-WAY

The right-of-way for the work to be constructed will be provided by the DISTRICT. The Contractor shall make his own arrangements and pay all expenses for additional area required by him outside of the limits of the right-of-way, unless otherwise provided in the special conditions.

#### 1-14 TIME AND ORDER OF WORK

- (a) The Contractor shall at all times employ such force, plant, materials and tools as will be sufficient, in the opinion of the General Manager, to complete the work or any separable portions thereof in accordance with a progress schedule and within the time limit fixed by the Contract. If the Contractor should fail to employ sufficient force, plant, materials and tools or to maintain adequate progress he may, after such failure, be required to increase his progress at any point or points or to modify his plans and procedures in such manners and to such extent as the General Manager may direct, any extension of such shall not relieve the Contractor from the necessity of maintaining the required progress. In case of an extension by the General Manager of the time for the completion of the Contract, as hereinafter provided a revised schedule of progress may be prescribed in accordance with such extension of time.
- (b) The time in which the various portions and the whole of the Contract are to be performed and the work is to be completed is of the essence of the Contract.

#### 1-15 ASSIGNMENT FOR PROPOSAL DEN

The Contractor shall not assign, transfer, convey or otherwise dispose of this Contract, or of his right, title or interest in or to the same or any part thereof, without the previous consent in writing of the General Manager and he shall not assign, by power of attorney or otherwise, any of the monies to become due and payable under the Contract unless by and with the like consent signified in like manner. If the Contractor shall, without such previous written consent, assign, transfer, convey or otherwise dispose of the Contract or of his right, title or interest therein, or of any of the monies to become due under the Contract, to any other person, company or other corporation, the Contract may at the option of the DISTRICT be terminated and revoked, and the DISTRICT shall thereupon be relieved and discharged from any and all liability and obligations growing out of the same to the Contractor, and to his assignee or transferee.

No right under the Contract, nor any right to any money to become due hereunder, shall be asserted against the DISTRICT in law or equity by reason of any so-called assignment of the Contract, or any part thereof, or by reason of the assignment of any

monies to become due hereunder, unless authorized as aforesaid by the written consent of the General Manager.

#### 1-16 SUBLETTING

The Contractor shall give his personal attention of the fulfillment of the Contract and shall keep the work under his control. Subcontractors will not be recognized as such, and all persons engaged in the work of construction will be considered as employees of the Contractor, and their work shall be subject to the provisions of the Contract and specifications. Where a portion of the work sublet by the Contractor is not being prosecuted in a manner satisfactory to the General Manager, the subcontractor shall be removed immediately on the recommendation of the General Manager and shall not again be employed on the work.

#### 1-17 SUSPENSION OF CONTRACT

- (a) If the work to be done under the Contract shall be abandoned by the Contractor, or if the Contractor shall make a general assignment for the benefit of his creditors or be adjudicated a bankrupt, or if a receiver of his property or business is appointed by a court of competent jurisdiction, or if this Contract shall be assigned by him otherwise than hereinbefore specified, or if at any time the General Manager shall be of the opinion that the performance of the Contract is unnecessarily or unreasonably delayed, or that the Contractor is willfully violating any of the conditions or covenants of the Contract, or of the specifications, or is executing the same in bad faith or not in the time named in the Contract for its completion or within the time to which the completion of the Contract may have been extended as hereinbefore provided, the General Manager, acting on behalf of the DISTRICT, may, by written notice, instruct the Contractor to discontinue all work or any part thereof under this Contract.
- (b) When such written notice is served upon the Contractor as provided in Section 1-06, he shall immediately discontinue the work or such part thereof as is covered by the notice and shall not resume the same except by written instructions from the General Manager. In any such case, the DISTRICT may take charge of the work and complete it by a new contract or by force account. In so doing, the DISTRICT may take possession of and use any of the materials, plant, tools, equipment, supplies and property of every kind provided by the Contractor for the purposes of his work. The DISTRICT may procure other materials and provide labor for the completion of same, or contract therefore and charge the expense of completion by either method to the Contractor. These charges shall be deducted from such monies as may be due or may at any time hereafter become due the Contractor under and by virtue of this Contract or any part thereof. In case such expense shall exceed the amount which would have been due the Contractor under the Contract if the same had been completed by him, he shall pay the amount of such excess to the DISTRICT; and in case such expense shall be less than the amount which would have been payable under this Contract if the same



had been completed by the Contractor, he shall have no claim to the difference except to such extent as may be necessary, in the opinion of the General Manager, to reimburse the Contractor or the Contractor's sureties for any expense, properly incurred for plant, equipment, materials, supplies and labor devoted to the prosecution of the work of which the DISTRICT shall have received the benefit and which shall not have been otherwise paid for by the DISTRICT. In computing such expense so far as it shall be deducted from the depreciated value thereof at the time taken over by the DISTRICT and the difference shall be considered as an expense. Evidence of such expense satisfactory to the General Manager, shall be required, and all necessary estimates and appraisements shall be made by him.

When any particular part of the work is being carried on for the DISTRICT by contract or otherwise, under the provisions of this section, the Contractor shall continue the remainder of the work in conformity with the terms of the Contract, and in such manner as in nowise to hinder or interfere with the persons or workmen employed, as above provided, by the DISTRICT, by contract or otherwise to do any part of the work or to complete the same under the provisions of this section.

1-18 SUSPENSION OF WORK - EXTENSION OF TIME - NO EXTRA COMPENSATION

- (a) The General Manager shall have the authority to suspend the work wholly or in part, for such period as he may deem necessary, due to unsuitable weather, or to such other conditions as are considered unfavorable for the suitable prosecution of the work or for such time as he may deem necessary due to the failure on the part of the Contractor to carry out orders given or to perform any provisions of the work. The Contractor shall immediately obey such order of the General Manager.
- (b) Applications for extension of time must be made promptly in writing, stating cause. No delay shall be made the basis in any application for extension of time, unless such delay and the cause thereof shall have been called to the attention of the General Manager in writing within the ten (10) days from the beginning of such delay. Applications for extension of time shall be addressed to the General Manager.
- (c) Permitting the Contractor to continue and finish the work, or any part of it, after the date to which the time fixed for its completion may have been extended, shall in nowise operate as a waiver on the part of the DISTRICT or any of its rights under this contract.
- (d) The Contractor shall receive no compensation on account of any suspension of the work either in whole or in part or for any delay or hindrance herein mentioned except as provided in the Detail Specifications.

## 1-19 FAILURE TO COMPLETE ON TIME AND LIQUIDATED DAMAGES

- (a) The Contractor shall pay for each and every day, including Sundays and legal holidays that they shall be in default in completing the whole work to be done under this Contract, the sum named in the Special Provisions, which sum is by the execution of the Agreement mutually agreed upon as liquidated damages which the DISTRICT will suffer by reason of such default. The DISTRICT shall have the right to deduct the amount of such damages from any monies due or to become due the Contractor under this Contract.
- (b) It is further agreed that in case the work called for under the Contract is not finished and completed in all parts and requirements within the time specified, the DISTRICT Board shall have the right to extend the time for completion or not, as may seem best to serve the interest of the DISTRICT; and if it decides to extend the time limit for the completion of the Contract, it shall further have the right to charge to the Contractor, his heirs, assigns or sureties and to deduct from the final payment for the work, all or any part, as it may deem proper of the actual cost of engineering, inspection, superintendence and other overhead expenses which are directly chargeable to the Contract and which accrue during the period of such extension, except that the cost of final surveys and preparation of final estimate shall not be included in such charges.
- (c) The Contractor shall not be assessed with liquidated damages nor the cost of engineering and inspection during any delay in the completion of the work caused by the acts of God or of the public enemy, acts of the DISTRICT, fire, floods, epidemics, quarantine restrictions, strikes, freight embargoes and unusually severe weather or delays of subcontractors due to such causes; provided, that the Contractor shall within ten (10) days from the beginning of any such delay notify the General Manager in writing of the causes of delay, who shall ascertain the facts and the extent of delay, and his findings of the facts thereon shall be final and conclusive.

## 1-20 CHANGES

- (a) If either the General Manager or the Contractor on account of conditions which develop during the progress of the work finds it impracticable to comply strictly with these specifications, the General Manager may prescribe a modification of requirements of methods of work. For such purposes, the General Manager may at any time during the life of the Contract, by written order make such changes as he shall find necessary in the design, line, grade, form, location, dimensions, plan or material of any part of the work or equipment hereinafter specified, or in the quantity or character of the work or equipment to be furnished. If such changes increase or diminish the quantity or amount of work to be done, they shall not constitute the basis for a claim for damages or anticipated profits on the work that may be dispensed with; provided, that if such

changes or alterations render useless, any work already done or materials already furnished or used in the work, the General Manager shall make reasonable allowance therefore, which action shall be binding upon both parties.

- (b) In the event of increasing or decreasing of work, the total amount of work actually done or materials or equipment furnished shall be paid for according to the unit price established for such work under the Contract, wherever such unit price has been established. In the event no prices are named in the Contract to cover such changes or alteration, the cost of such changes shall be covered as hereinafter provided for extra work.
- (c) The DISTRICT reserves the right to increase or decrease the quantity of any item or portion of work or to omit portions of the work as may be deemed necessary or expedient by the General Manager.

#### 1-21 EXTRA WORK

- (a) If during the performance of the Contract, it shall, in the opinion of the General Manager, become necessary or desirable for proper completion of the Contract to order work done or materials or equipment furnished which in the opinion of the General Manager are not susceptible of classification under the proposal items, the Contractor shall do and perform such work and furnish such materials and equipment as extra work, as hereinafter provided. All extra work shall be ordered in writing before it is started. No extra work shall be paid for unless ordered in writing.
- (b) Extra work will ordinarily be paid for at a lump sum or unit price agreed upon in writing by the General Manager and the Contractor before the extra work shall be ordered.
- (c) Whenever in the judgment of the General Manager extra work or extra material, as the case may be, is not of like character to and is not susceptible of classification under the proposal items of the Contract as specified, and it is impracticable because of the nature of the work, or for any other reason to fix the price before the extra work order shall be issued, extra work and material, when furnished by the Contractor, shall be paid for at actual necessary cost of materials, supplies, labor (including foremen's wages), workers' compensation insurance, contributions made to the State as required by the provisions of the Unemployment Insurance Act, Chapter 352, Statutes of 1935, as amended, taxes paid to the Federal Government as required by The Social Security Act, approved August 14, 1935, as amended and the reasonable value of the use of equipment for the actual time it is used, all as determined by the General Manager, plus fifteen percent (15%) to cover the following:

Profit  
General Expenses

All insurance except workers' compensation insurance  
Excise taxes  
Property taxes  
Bond premiums  
License and inspection fees imposed by any governmental authority  
Any and all other items of expense not specifically mentioned under subsection (c) herein

The General Manager determination and certification of said actual necessary cost shall be binding and conclusive on the Contractor, and the General Manager shall be deemed the arbiter to determine the cost of such work.

(d) If any work or materials be ordered under this section on a cost-plus basis, the Contractor shall, at the times directed during the performing of the work or the furnishing of the materials, render to the General Manager, written reports in prescribed form, showing all items that may enter into the cost, the quantity and the character of each such material, from whom purchased and the net amount paid or to be paid therefore, and such other information as directed. If required, the Contractor shall produce any books, vouchers, other records or memoranda, which will assist the General Manager in determining the true, necessary cost of the work and materials to be paid for.

(d) Any extra work performed hereunder shall be subject to all the provisions of the Contract and the Contractor's sureties shall be bound with reference thereto as under the Contract.

### 1-23 PROGRESS ESTIMATES

The General Manager, shall on or about the fifth (5<sup>th</sup>) day of each calendar month, except as provided in Section 1-24, make in writing and certify to the DISTRICT an estimate such as in his opinion shall be just and fair, of the amount and value of the work done by the Contractor and of the amount and value of all acceptable materials furnished and delivered by the Contractor to the site and not used up to that time in the performance of the Contract. To the figure thus arrived at, shall be added any amounts due the Contractor for extra work and the amount of any approved claims for extra cost to the date of the progress estimate.

A deduction of ten percent (10%) shall be made from the estimated value of the work done and fifty percent (50%) of the value of the materials so estimated to have been furnished and delivered and unused, and from the remainder there shall be further deducted any amounts due the DISTRICT from the Contractor for supplies or materials furnished or services rendered and any other amounts that may be due the DISTRICT under the terms of the Contract. From the balance thus determined shall be deducted the amount of all previous payments and the remainder shall constitute the progress estimate for that month.

Such progress estimates shall not be required to be made by strict measurement, but they may be made by measurement or by estimation, or partly by one method or partly by the other, and it shall be sufficient if they are approximate only.

Pursuant to California Public Contract Code Section 22300, the Contractor has the option of substituting securities for any money that is withheld under this section.

#### 1-24 PROGRESS ESTIMATES MAY BE WITHHELD

The progress estimates provided for in Section 1-23 hereof may at any time be withheld or reduced if, in the opinion of the General Manager, the Contractor is not diligently and efficiently endeavoring to comply with the intent of the Contract, or if the Contractor shall fail to pay his labor and material bills as they become due.

#### 1-25 PROGRESS PAYMENTS

- (a) Upon each progress estimate being made and certified in writing, the DISTRICT shall, within fifteen (15) days after the date of such estimates, except as stipulated in subsection (b) hereof, pay to the Contractor the amount stated in such estimates to be due the Contractor; provided, however, that the DISTRICT may at all times reserve and retain from such progress payments, in addition to the retained percentage and other amounts above mentioned to be deducted in computing the progress estimated, any sum or sums which by the terms hereof, or of any law of the State of California, it is or may be authorized or required to reserve or retain; and provided further, that no progress estimate or progress payment shall constitute an acceptance of the work or any portion thereof. The percentage deducted as above set forth shall become due and payable with and as a part of the final payment to be made as hereinafter provided.
- (b) In the event the contract or any part thereof shall be suspended as provided in Section 1-17, the retained percentage as provided in Section 1-23, shall become the sole and absolute property of the DISTRICT to the extent necessary to repay to the DISTRICT any excess in the cost of the work above the Contract price. After issuance of notice to discontinue work, no payments upon progress estimates or otherwise shall thereafter be made the Contractor for the work covered by said notice until completion of the work.

#### 1-26 FINAL ESTIMATE AND PAYMENT

- (a) Whenever in the opinion of the General Manager the Contractor shall have completely performed the Contract on his part, the General Manager will submit to the Contractor a written statement of the final quantities of Contract items for inclusion in the final estimate. The Contractor will be expected to submit his written approval of said proposed final quantities within five (5) days of receipt of the General Manager' statement, or in the event the Contractor disagrees with

such written statement, shall within said period of five (5) days file a written statement of all claims, which he intends to present.

- (b) All prior estimates upon which partial payments have been made shall be subject to correction in the final estimate. The final estimate and payments made thereunder shall be final and conclusive upon the Contractor.

#### 1-27 RECOVERY OF DAMAGES

The making of an estimate and payment in accordance therewith shall not preclude the DISTRICT from demanding and recovering from the Contractor such damages as it may sustain by reason of his failure to comply with the specifications.

#### 1-28 FINAL PAYMENT TERMINATES LIABILITY

The acceptance by the Contractor of the final payment aforesaid shall be a release to the DISTRICT and its agents from all claim and liability to the Contractor for anything done or furnished for or relating to the work or for any act or neglect of the DISTRICT or of any person relating to or affecting the work except the claim against the DISTRICT for the remainder, if any, of the amount kept or retained as provided in Section 1-31.

#### 1-29 NO PERSONAL LIABILITY

No agent of the DISTRICT shall be personally responsible for any liability arising under the Contract. No claims shall be made or filed and neither the DISTRICT nor any of its agents shall be liable for or held to pay any money, except as specifically provided in the Contract.

#### 1-30 MONIES MAY BE RETAINED

The DISTRICT may keep any monies which would otherwise be payable at any time hereunder and apply the same, or so much as may be necessary therefore, to the payment of any expense, losses or damages as determined by the General Manager incurred by the DISTRICT for which the Contractor is liable under the Contract.

#### 1-31 UNPAID CLAIMS

If, upon or before the completion of the work herein agreed to be performed or at any time prior to the expiration of the period within such claims of liens may be filed for the record as prescribed by Section 3179 of the Civil Code of the State of California, any person or persons claiming to have performed any labor or furnished any material, supplies or services toward the performance or completion of this Contract, or that they have agreed to do so, shall file with the DISTRICT a verified statement of such claim, stating in general terms the kind of labor and materials and the name of the person to or for whom the same was done or furnished, or both, together with a statement that the same has not been paid or if any person or persons shall bring against the DISTRICT or

against any agent or agents thereof any action to enforce such claim, the DISTRICT shall until the discharges thereof withhold from the monies under its control so much of said monies due or to become due the Contractor under this Contract as shall be sufficient to satisfy and discharge the amount in such notice or under such action claimed to be due, together with the costs thereof; provided that if the DISTRICT shall in its discretion permit the Contractor to file such additional bonds as is authorized by Section 3196 of the Civil Code, in a penal sum equal to one and one-fourth (1¼) times the amount of said claim, said monies shall not thereafter be withheld on account of such claim.

#### 1-32 ADDITIONAL SURETY

If during the continuance of the Contract, any of the sureties upon the faithful performance bond in the opinion of the General Manager are/or become insufficient, he may require additional sufficient sureties which the Contractor shall furnish, to the satisfaction of the General Manager, within fifteen (15) days after notice and in default thereof the contract may be suspended and the work completed as provided in Section 1-17 hereof.

#### 1-34 PAYMENT OF WAGES

The issuance as payment for wages of any evidence of indebtedness is prohibited unless the same is negotiable and payable on demand without discount. Wages must be paid at least semimonthly on regular pay days established in advance, and shall include all amounts for labor or services performed by employees of every description as required under the provisions of the California Labor Code.

#### 1-36 OVERTIME - NO EXTRA COMPENSATION

Overtime work (i.e., work in excess of eight (8) hours in any one (1) calendar day or work performed on a Sunday or other legal holiday) shall not entitle the Contractor to any compensation for any Contract item in addition to that stipulated in the Contract for the kind of work performed even though such overtime or legal holiday work may be required under emergency conditions, and may be ordered by the General Manager in writing. In case of extra work ordered by the General Manager under the provisions of Section 1-21 hereof, no additional payment will be made to the Contractor because of the payment by him of overtime or legal holiday rates for such work, unless the use of overtime or legal holiday work in connection with such extra work is specifically ordered in writing by the General Manager and then only to such extent as extra payment is regularly being made by the Contractor to his workers for overtime or legal holiday work of a similar nature in the same locality.

#### 1-37 CHARACTER OF WORKMEN

None but skilled workers shall be employed on work requiring special qualifications. When required in writing by the General Manager, the Contractor or any subcontractor

shall discharge any person who is in the opinion of the General Manager, incompetent, unfaithful, disorderly or otherwise unsatisfactory and shall not again employ such discharged person on the work except with the consent of the General Manager. Such discharge shall not be the basis of any claim for compensation or damage against the DISTRICT or any of its officers.

#### 1-38 SAMPLES AND TESTS

At the option of the General Manager, the source of supply of each of the materials shall be approved by the General Manager before delivery is started and before such material is used in the work. Representative preliminary samples of the character and quality prescribed shall be submitted by the Contractor or producer of all materials to be used in the work for testing or examination as desired by the General Manager.

All tests of materials furnished by the Contractor shall be made in accordance with commonly recognized standards of national organizations, and such special methods and tests are prescribed in these specifications.

The Contractor shall furnish such samples of materials as are requested by the General Manager, without charge. No material shall be used until it has been approved by the General Manager. Samples will be secured and tested whenever necessary to determine the quality of material.

#### 1-39 INSPECTION

The General Manager shall at all times have access to the work during construction, and shall be furnished with every reasonable facility for ascertaining full knowledge respecting the progress, workmanship and character of materials used and employed in the work.

Whenever the Contractor varies the period, which work is carried on each day, he shall give due notice to the General Manager, so that proper inspection may be provided. Any work done in the absence of the General Manager will be subject to rejection. The inspection of the work shall not relieve the Contractor of any of his obligations to fulfill the contract as prescribed. Defective work shall be made good and unsuitable materials may be rejected notwithstanding the fact that such defective work and unsuitable materials have been previously overlooked by the General Manager and accepted or estimated for payment.

#### 1-40 DEFECTIVE WORK OR MATERIALS

- (a) If the work, or any part thereof, shall be found defective at any time before the final acceptance of the whole work, the Contractor shall forthwith make good such defects without compensation in a manner satisfactory to the General Manager, and the cost of any excess material furnished by the DISTRICT shall be borne by the Contractor.



- (b) All materials not conforming to the requirements of these specifications shall be considered as defective and all such material whether in place or not shall be rejected and shall be removed immediately from the site of the work unless otherwise permitted by the General Manager. No rejected material, the defects of which have been subsequently corrected shall be used until approved in writing by the General Manager.
- (c) Upon failure on the part of the Contractor to comply with any order of the General Manager made under the provisions of this article, the General Manager shall have authority to remove and replace defective material and to deduct the cost of removal and replacement from any monies due or to become due the Contractor.

#### 1-41 USE OF COMPLETED PORTIONS

The DISTRICT may at any time during progress of the work, after written notice to the Contractor, take over and place in service any completed portions of the work which are ready for service, although the entire work of the Contract is not fully completed and notwithstanding the time for completion of the entire work or such portions which may not be expired. In case, the DISTRICT shall issue certificates of acceptance for such portions of the work but such taking possession thereof shall not be deemed an acceptance of any other portion of the work, nor of any incomplete portions, nor of any work not completed in accordance with the contract documents.

#### 1-42 PROPERTY RIGHTS IN MATERIALS

Nothing in this Contract shall be construed as vesting in the Contractor any right of property in the materials used after they have been attached or affixed to the work or the soil or after payment has been made for the value of unused material delivered to the site of the work as provided for in Section 1-23 hereof. All such materials attached or affixed or unused shall become the property of the DISTRICT.

#### 1-43 TITLE TO MATERIALS FOUND ON THE WORK

The right to the use of all soil, stone, gravel, sand and all other materials and equipment developed or obtained in the excavation or other operations by the Contractor or any subcontractor or any of their employees and the right to use and/or dispose of the same are hereby expressly reserved in the DISTRICT and neither the Contractor, nor any subcontractor nor any of their employees shall have any right, title or interest in or to any part thereof nor shall they, nor any of them, assert or make any claim thereto. The Contractor shall be permitted to use in the work, without charge, any such materials, which meet the requirements of these specifications.

#### 1-44 ENFORCEMENT OF ORDER

The Contractor shall be responsible for maintaining good order at the site where work is performed under this Contract and to that end shall employ such watchmen or other persons as may be required. Unauthorized persons shall be excluded from the site of the work. The Contractor shall not sell, nor shall he permit or suffer the introduction or use of intoxicating liquors or narcotics upon the works embraced in these specifications or upon any of the grounds occupied or controlled by him in connection with such works.

#### 1-45 PATENTS AND COPYRIGHTS

The Contractor shall hold and save the DISTRICT, its officers, agents and employees harmless from liability of any nature and kind including costs and expenses for or on account of any copyrighted or un-copyrighted composition, secret process, patented or unpatented invention, article or appliance manufactured, furnished or used by him in the performance of this Contract, including their use by the DISTRICT, unless otherwise specifically stipulated in the Contract.

#### 1-46 LAWS AND REGULATIONS

- (a) The Contractor shall keep himself fully informed of all Federal and State laws, County and DISTRICT ordinances and regulations which in any manner affect those engaged or employed on the work or the materials used in the work or in any way affecting the conduct of the work. If any discrepancy or inconsistency should be discovered in this Contract, or in the drawings or specifications herein referred to in relation to any such law, ordinance or regulation, he shall forthwith report the same in writing to the General Manager. He shall, at all times, observe and comply with and shall cause all his agents and employees to observe and comply with all such applicable laws, ordinances and regulations in effect or which may become effective before completion of this Contract. He shall protect and indemnify the DISTRICT and its officers and agents against any claim or liability arising from or based on the violation of any such law, ordinance or regulation whether by himself or by his employees.
- (b) Except as otherwise explicitly provided elsewhere in these specifications, all permits and licenses necessary to the prosecution of the work shall be secured by the Contractor at his own expense, and he shall pay all taxes properly assessed against his equipment or property used or required in connection with the work.
- (c) All Federal laws and regulations now imposed by competent authority and relating to any materials required to be furnished under these specifications and work required to be done hereunder shall be deemed to be and hereby are made controlling and part of these specifications.

## 1-47 SALES AND/OR USE TAXES

Except as may be otherwise provided herein, all sales and/or use taxes assessed by Federal, State or local authorities on materials used or furnished by the Contractor in performing the work hereunder shall be paid by the Contractor.

## 1-48 RESPONSIBILITY FOR DAMAGE

### (a) Indemnity Agreement

Except for the gross negligence or willful misconduct of an Indemnitee (as hereinafter defined), the Contractor hereby assumes liability for and agrees to defend (at Indemnitees' option), indemnify, protect and hold harmless DISTRICT and its Project Consultants and Engineers, officers, agents and employees ("Indemnitees") from and against any and all claims, charges, damages, demands, actions, proceedings, losses, stop notices, costs, expenses (including counsel fees), judgments, civil fines and penalties, liabilities of any kind or nature whatsoever, which may be sustained or suffered by or secured against the Indemnitees arising out of or encountered in connection with this Contract or the performance of the work including, but not limited to, death of or bodily or personal injury to persons or damage to property, including property owned by or under the care and custody of DISTRICT, and for civil fines and penalties, that may arise from or be caused, in whole or in part, by any negligent or other act or omission of the Contractor, its officers, agents, employees or subcontractors including, but not limited to, liability arising from:

1. Any dangerous, hazardous, unsafe or defective condition of, in or on the premises, of any nature whatsoever, which may exist by reason of any act, omission, neglect or any use of occupation of the premises by the Contractor, its officers, agents, employees or subcontractors;
2. Any operation conducted upon or any use or occupation of the premises by the Contractor, its officers, agents, employees or subcontractors under or pursuant to the provisions of this contract or otherwise;
3. Any act, omission or negligence of the Contractor, its officers, agents, employees or subcontractors.
4. Any failure of the Contractor, its officers, agents or employees to comply with any of the terms or conditions of this Contract or any applicable Federal, State, regional or municipal law, ordinance, rule or regulation; and
5. The conditions, operations, uses, occupations, acts, omissions or negligence referred to in sub-subsections (1), (2), (3) and (4), existing or conducted upon or arising from the use or occupation by the Contractor on any other premises in the care, custody and control of the DISTRICT.

The Contractor also agrees to indemnify the DISTRICT and pay for all damage or loss suffered by the DISTRICT including but not limited to damage to or loss of DISTRICT property, to the extent not insured by the DISTRICT and loss of DISTRICT revenue

from any source, caused by or arising out of the conditions, operations, uses, occupations, acts, omissions or negligence referred to in sub-subsections (1), (2), (3), (4) and (5).

The Contractor's obligations under this section apply regardless of whether or not such claim, charge, damage, demand, action, proceeding, loss, stop notice, cost, expense, judgment, civil fine or penalty or liability was caused in part or contributed to by an Indemnitee. However, without affecting the rights of the DISTRICT under any provision of this Contract, the Contractor shall not be required to indemnify and hold harmless the DISTRICT for liability attributable to the active negligence of the DISTRICT, provided such active negligence is determined by agreement between the parties or by the findings of a court of competent jurisdiction. In instances where the DISTRICT is shown to have been actively negligent and where the DISTRICT's active negligence accounts for only a percentage of the liability involved, the obligation of the Contractor will be for that entire portion or percentage of liability not attributable to the active negligence of the DISTRICT.

The Contractor agrees to obtain executed indemnity agreements with provisions identical to those set forth here in this section from each and every subcontractor or any other person or entity involved by, for, with or on behalf of the Contractor in the performance of this Contract. In the event the Contractor fails to obtain such indemnity obligations from others as required here, the Contractor agrees to be fully responsible according to the terms of this section.

Failure of the DISTRICT to monitor compliance with these requirements imposes no additional obligations on the DISTRICT and will in no way act as a waiver of any rights hereunder. This obligation to indemnify and defend the DISTRICT as set forth here is binding on the successors, assigns or heirs of the Contractor and shall survive the termination of this Contract or this section.

This Indemnity shall survive termination of the Contract of Final Payment hereunder. This Indemnity is in addition to any other rights or remedies that the Indemnitees may have under the law or under any other Contract Documents or agreements. In the event of any claim or demand made against any party which is entitled to be indemnified hereunder, the DISTRICT may, in its sole discretion, reserve, retain or apply any monies to the Contractor under this Contract for the purpose of resolving such claims; provided, however, the DISTRICT may release such funds if the Contractor provides the DISTRICT with reasonable assurance of protection of the Indemnitees' interests. The DISTRICT shall, in its sole discretion, determine whether such assurances are reasonable.

(b) Insurance Requirements

Prior to the beginning of and throughout the duration of the work, the Contractor will maintain insurance in conformance with the requirements set forth below. The Contractor will use existing coverage to comply with these requirements. If

that existing coverage does not meet the requirements set forth here, it will be amended to do so. The Contractor acknowledges that the insurance coverage and policy limits set forth in this section constitute the minimum amount of coverage required. Any insurance proceeds available to the DISTRICT in excess of the limits and coverage required in this Contract and which is applicable to a given loss, will be available to the the DISTRICT.

The Contractor shall provide the following types and amounts of insurance:

1. **Commercial General Liability Insurance** using Insurance Services Office “Commercial General Liability” policy form CG 00 01 or the exact equivalent. Defense costs must be paid in addition to limits. There shall be no cross liability exclusion for claims or suits by one insured against another. Limits shall be no less than one million dollars (\$1,000,000) per occurrence for all covered losses and no less than two million dollars (\$2,000,000) general aggregate.

The Contractor’s policy shall contain no endorsements limiting coverage beyond the basic policy coverage grant for any of the following:

- Explosion, collapse or underground hazard (XCU)
- Products and completed operations
- Pollution liability
- Contractual liability

Coverage shall be applicable to the DISTRICT for injury to employees of contractors, subcontractors or others involved in the project. Policy shall be endorsed to provide a separate limit applicable to this project.

2. **Workers’ Compensation** on a State-approved policy form providing statutory benefits as required by law with employer’s liability limits no less than one million dollars (\$1,000,000) per accident for all covered losses.
3. **Business Auto Coverage** on ISO Business Auto Coverage form CA 00 01 06 92 including symbol 1 (Any Auto) or the exact equivalent. Limits shall be no less than one million dollars (\$1,000,000) per accident, combined single limit. If the Contractor owns no vehicles, this requirement may be satisfied by a non-owned auto endorsement to the general liability policy described above. If the Contractor or the Contractor’s employees will use personal autos in any way on this project, the Contractor shall provide evidence of personal auto liability coverage for each such person.
4. **Excess or Umbrella Liability Insurance** (Over Primary) if used to meet limit requirements, shall provide coverage at least as broad as

specified for the underlying coverages. Any such coverage provided under an umbrella liability policy shall include a drop-down provision providing primary coverage above a maximum twenty-five thousand dollars (\$25,000) self-insured retention for liability not covered by primary but covered by the umbrella. Coverage shall be provided on a "pay on behalf" basis, with defense costs payable in addition to policy limits. There shall be no cross-liability exclusion precluding coverage for claims or suits by one insured against another. Coverage shall be applicable to the DISTRICT for injury to employees of the Contractor, subcontractors or others involved in the work. The scope of coverage provided is subject to approval of the DISTRICT following receipt of proof of insurance as required herein. Limits are subject to review but in no event less than two million dollars (\$2,000,000) per occurrence and aggregate.

5. **Professional Liability or Errors and Omissions Insurance** as appropriate shall be written on a policy form coverage specifically designed to protect against acts, errors or omissions of the Contractor and "Covered Professional Services" as designated in the policy must specifically include work performed under this Contract. The policy limit shall be no less than one million dollars (\$1,000,000) per claim and in the aggregate. The policy must "pay on behalf of" the insured and must include a provision establishing the insurer's duty to defend. The policy retroactive date shall be on or before the effective date of this Contract.
6. **Course of Construction** insurance shall provide "all risk" coverage for the completed value of the project. Policies shall contain the following provisions: (1) the DISTRICT shall be named as loss payee; and (2) the insurer shall waive all rights of recovery against the DISTRICT.

Insurance procured pursuant to these requirements shall be written by insurers that are admitted carriers in the State of California and with an A.M. Best rating of A- or better and minimum financial size VII.

(c) **Additional Requirements**

The Contractor and the DISTRICT further agree as follows:

1. The Contractor agrees to have its insurer endorse the third-party general liability coverage required herein to include as additional insureds DISTRICT, its officials, employees and agents, using standard ISO endorsement No. CG 2010 1001 and CG 2037 1001 with an edition 2001 or prior to 1992, or equivalent provisions as determined by the Office of the DISTRICT Attorney for the DISTRICT in its sole discretion. The Contractor also agrees to require all contractors, subcontractors and anyone else involved in any way with the project contemplated by this Contract, to do likewise.

2. Any waiver of subrogation express or implied on the part of the DISTRICT to any party involved in this Contract or related documents applies only to the extent of insurance proceeds actually paid. The DISTRICT, having required that it be named as an additional insured to all insurance coverage required herein, expressly retains the right to subrogate against any party for sums not paid by insurance. For its part, the Contractor agrees to waive subrogation rights against the DISTRICT regardless of the applicability of any insurance proceeds, and to require all contractors, subcontractors or others involved in any way with the project contemplated by this Contract to do likewise.
3. All insurance coverage maintained or procured by the Contractor or required of others by the Contractor pursuant to this Contract shall be endorsed to delete the subrogation condition as to the DISTRICT, or to specifically allow the Contractor or others providing insurance herein to waive subrogation prior to a loss. This endorsement shall be obtained regardless of existing policy wording that may appear to allow such waivers.
4. It is agreed by the Contractor and the DISTRICT that insurance provided pursuant to these requirements is not intended by any party to be limited to provided coverage for the vicarious liability of the DISTRICT, or to the supervisory role, if any, of the DISTRICT. All insurance coverage provided pursuant to this Contract in any way relating to the DISTRICT is intended to apply to the full extent of the policies involved. Nothing referred to here or contained in any agreement involving the DISTRICT in relation to the project(s) contemplated by this Contract is intended to be construed to limit the application of insurance coverage in any way.
5. None of the coverages required herein will be in compliance with these requirements if they include any limiting endorsement of any kind that has not been first submitted to the DISTRICT and approved of in writing.
6. All coverages types and limits required are subject to approval, modification and additional requirements by the DISTRICT, as the need arises. The Contractor shall not make any reductions in scope of coverage (e.g. elimination of contractual liability or reduction of discovery period) which may affect the DISTRICT's protection without the DISTRICT's prior written consent.
7. Proof of compliance with these insurance requirements, consisting of binders of coverage or endorsements, or certificates of insurance, at the option of the DISTRICT, shall be delivered to the DISTRICT at or prior to the execution of the Contract. In the event such proof of any insurance is not delivered as required, or in the event such insurance is canceled at any time and no replacement coverage is provided, the DISTRICT has the right, but not the duty, to obtain any insurance it deems necessary to protect its interests under

- this Contract and to pay the premium. Any premium so paid by the DISTRICT shall be charged to and promptly paid by the Contractor or deducted from sums due the Contractor, at the DISTRICT option.
8. The Contractor agrees to endorse, and to require others to endorse, the insurance provided pursuant to these requirements, to require thirty (30) days notice to the DISTRICT and the appropriate tender prior to cancellation of such liability coverage and notice of any material alteration or non-renewal of any such coverage, and to require contractors, subcontractors and any other party in any way involved with the project contemplated by this Contract to do likewise.
  9. It is acknowledged by the parties of this Contract that all insurance coverage required to be provided by the Contractor or any subcontractor, is intended to apply first and on a primary non-contributing basis in relation to any other insurance or self insurance available to the DISTRICT.
  10. The Contractor agrees to ensure that subcontractors and any other party involved with the project that is brought onto or involved in the project by the Contractor, provide the same minimum insurance coverage required of the Contractor. The Contractor agrees to monitor and review all such coverage and assumes all responsibility for ensuring that such coverage is provided in conformity with the requirements of this section. The Contractor agrees that upon request, all agreements with subcontractors and others engaged in the project will be submitted to the DISTRICT for review.
  11. The Contractor agrees that all layers of third-party liability coverage required herein, primary, umbrella and excess, will have the same starting and expiration date. The Contractor agrees further that all other third-party coverages required herein will likewise have concurrent starting and ending dates.
  12. The Contractor agrees not to self-insure or to use any self-insured retentions or deductibles on any portion of the insurance required herein and further agrees that it will not allow any contractor, subcontractor, architect, engineer or other entity or person in any way involved in the performance of work on the project contemplated by this Contract to self-insure its obligations to the DISTRICT. If the Contractor's existing coverage includes a deductible or self-insured retention, the deductible or self-insured retention must be declared to the DISTRICT. At that time the DISTRICT shall review options with the Contractor, which may include reduction or elimination of the deductible or self-insured retention, substitution of other coverage or other solutions.
  13. The DISTRICT reserves the right at any time during the term of the Contract to change the amounts and types of insurance required by giving the



- Contractor ninety (90) days advance written notice of such change. If such change results in substantial additional cost to the Contractor, the DISTRICT will negotiate additional compensation proportional to the increased benefit to the DISTRICT.
14. For purposes of applying insurance coverage only, all contracts pertaining to the project will be deemed to be executed when finalized and any activity commences in furtherance of performance under this Contract.
  15. The Contractor acknowledges and agrees that any actual or alleged failure on the part of the DISTRICT to inform the Contractor of non-compliance with any insurance requirement in no way imposes any additional obligations on the DISTRICT nor does it waive any rights hereunder in this or any other regard.
  16. The Contractor will renew the required coverage annually as long as the DISTRICT, or its employees or agents face an exposure from operations of any type pursuant to this Contract. This obligation applies whether or not the Contract is canceled or terminated for any reason. The insurance shall include but not be limited to products and completed operations and discontinued operations, where applicable. Termination of this obligation is not effective until the DISTRICT executes a written statement to that effect.
  17. The Contractor agrees to waive its statutory immunity under any workers' compensation statute or similar statute, in relation to the DISTRICT, and to require all subcontractors and any other person or entity involved in the project contemplated by this Contract to do likewise.
  18. Requirements of specific coverage features are not intended as limitations on other requirements or as a waiver of any coverage normally provided by any given policy. Specific reference to a given coverage feature is for purposes of clarification only as it pertains to a given issue, and is not intended by any party or insured to be all inclusive.
  19. Any provision in any of the construction documents dealing with the insurance coverage provided pursuant to these requirements is subordinate to and superseded by the requirements contained herein. These insurance requirements are intended to be separate and distinct from any other provision in this Contract and are intended by the parties here to be interpreted as such.
  20. All liability coverage provided according to these requirements must be endorsed to provide a separate aggregate limit for the project that is the subject of this Contract and evidencing products and completed operations coverage for not less than two (2) years after issuance of a final certificate of occupancy by all appropriate government agencies or acceptance of the completed work by the DISTRICT.

21. The Contractor agrees to be responsible for ensuring that no contract used by any party involved in any way with the project reserves the right to charge the DISTRICT or the Contractor for the cost of additional insurance coverage required by this Contract. Any such provisions are to be deleted with reference to the DISTRICT. It is not the intent of the DISTRICT to reimburse any third party for the cost of complying with these requirements. There shall be no recourse against the DISTRICT for payment of premiums or other amounts with respect thereto.

22. The Contractor agrees to obtain and provide to the DISTRICT a copy of professional liability coverage for architects or engineers working on this project through the Contractor. The DISTRICT shall determine the liability limit, if not otherwise specified in subsection (b) of this section 1-48.

#### 1-49 TRESPASS

The Contractor shall be responsible for all damage or injury, which may be caused on any property by trespass of the Contractor's employees in the course of their employment whether the said trespass was committed with or without the consent or knowledge of the Contractor.

#### 1-50 SAFETY, SANITARY AND MEDICAL REQUIREMENTS

The Contractor and his subcontractors, if any, and employees shall promptly and fully carry out the existing safety, sanitary and medical requirements as may from time to time be prescribed by the DISTRICT or by County or State Health Departments to the end that proper work shall be done and the safety and health of the employees and of the community may be observed and safeguarded. In case such regulations and orders are not observed by the Contractor they may be enforced by the General Manager at the Contractor's expense.

#### 1-51 PROTECTION AND CLEAN UP

The Contractor shall protect and care for all work until completion and acceptance thereof. Before the Contractor makes application for the acceptance of the work, all rubbish, excess earth and rock or surplus materials shall be removed leaving the site in a neat, orderly and presentable condition.

#### 1-52 LABOR DISCRIMINATION

No discrimination shall be made in the employment of persons upon public works because of the race, color, religious creed, national origin, ancestry, physical disability, mental disability, medical condition, marital status, gender, age or sexual orientation of such persons except as provided in Section 12940 of the California Government Code, and every contractor for public works violating Section 1735 of the California Labor

Code is subject to all penalties imposed for a violation of Chapter 1, of Part 7, of Division 2 of the California Labor Code.

#### 1-54 PRECONSTRUCTION CONFERENCE

Before the start of construction, the General Manager will arrange to meet with the Contractor to discuss the requirements on such matters as project supervision, on-site inspections, progress, schedules and reports, payment(s) to Contractor(s), safety and other items pertinent to the project. At this conference, all parties should be prepared to discuss any anticipated problems.

#### 1-55 SUBCONTRACTING LISTING

1. Any person making a proposal or offer to perform the work described in this Contract shall in his proposal or offer set forth:
  - a. The name and location of the place of business of each subcontractor who will perform work of labor or render service to the Contractor in or about the construction of the work or improvement or a subcontractor licensed by the State of California, who, under the subcontract to the Contractor, especially fabricates and installs a portion of the work or improvement according to detailed drawings contained in the plans and specifications in an amount in excess of one-half ( $\frac{1}{2}$ ) of one percent (1%) of the Contractor's total proposal.
  - b. The portion of the work, which will be done by each such subcontractor under this Contract. The Contractor shall list only one subcontractor for each such portion as is defined by the Contractor in his proposal.
2. No Contractor whose proposal is accepted shall, without the consent of the DISTRICT either:
  - a. Substitute any person as subcontractor in place of the subcontractor designated in the original proposal.
  - b. Permit any subcontractor to be assigned or transferred or allow it to be performed by any other than the original subcontractor listed in the proposal.
  - c. Sublet or subcontract any portion of the work in excess of one-half ( $\frac{1}{2}$ ) of one percent (1%) of the Contractor's proposal as to which his original proposal did not designate a subcontractor.
2. Subletting or subcontracting any portion of the work as to which no subcontractor was designated in the original proposal shall be permitted only in case of public emergency or necessity, and then only after a finding reduced to writing as public record of the awarding authority setting forth the facts constituting such emergency or necessity.

## 1-56 CERTAIN CLAIMS

- a) Notwithstanding the foregoing, any demand of three hundred seventy-five thousand dollars (\$375,000) or less, by the Contractor for a time extension, payment of money or damages arising from the work done by or on behalf of the Contractor pursuant to this Contract or payment of an amount which is disputed by the DISTRICT shall be processed in accordance with the provisions of Public Contracts Code Section 20104 *et seq.*
  - b) A single written claim shall be filed under this section prior to the date of final payment for all demands arising out of the Contract.
  - c) Within thirty (30) days of receipt of the claim, the DISTRICT may request additional documentation supporting the claim or relating to the defenses or claims the DISTRICT may have against the Contractor. If the amount of the claim is less than fifty thousand dollars (\$50,000), the Contractor shall respond to the request for additional information within fifteen (15) days after the receipt of the request. The Contractor shall respond to the request within thirty (30) days of receipt if the amount of the claim exceeds fifty thousand dollars (\$50,000) but is less than three hundred seventy-five thousand dollars (\$375,000).
  - d) Unless further documentation is requested, the DISTRICT shall respond to the claim within forty-five (45) days if the amount of the claim is less than fifty thousand dollars (\$50,000) or within sixty (60) days if the amount of the claim is more than fifty thousand dollars (\$50,000) but less than three hundred seventy-five thousand dollars (\$375,000). If further documentation is requested, the DISTRICT shall respond within the same amount of time taken by the Contractor to respond or fifteen (15) days, whichever is greater, after receipt of further information if the claim is less than fifty thousand dollars (\$50,000). If the claim is more than fifty thousand dollars (\$50,000) but less than three hundred seventy-five thousand dollars (\$375,000) and further documentation is requested by the DISTRICT, the DISTRICT shall respond within the same amount of time taken by the Contractor to respond or thirty (30) days, whichever is greater.
  - e) If the Contractor disputes the DISTRICT's response, or the DISTRICT fails to respond, the Contractor may demand an informal conference to meet and confer for settlement of the issues in dispute. The demand shall be served on the DISTRICT within fifteen (15) days after the deadline of the DISTRICT to respond or within fifteen (15) days of the Contractor's receipt of the DISTRICT's response.
- (e) If the meet and confer conference does not produce a satisfactory request, the Contractor may pursue remedies authorized by law.

END OF GENERAL CONDITIONS

## **SPECIAL PROVISIONS**

### **1.00 ORDER OF WORK**

Prior to commencement of any work on the project, a preconstruction conference will be held at the DISTRICT Engineer's Office for the purpose of review and discussion of progress schedule and construction procedures. At the discretion of the Engineer, periodic meetings involving project personnel (the Contractor, utility and others) will be held for the purpose of coordinating project activities.

Full compensation for conforming to these requirements will be considered included in the prices paid for the various contract items of work and no additional compensation will be allowed therefor.

**1.02 STARTING AND COMPLETION OF WORK** - The Contractor shall begin work within ten (10) working days after receiving "Notice to Proceed" from the DISTRICT, and shall diligently prosecute the work to completion before the expiration of one hundred (100) calendar days from the "date of beginning" as stated in the Notice to Proceed."

**1.03 FAILURE TO COMPLETE ON TIME AND LIQUIDATED DAMAGES** - (See General Conditions 1-19). It is agreed by the parties to the Contract that in case of all work called for under the Contract is not completed before or upon the expiration of the time limits set forth in these Special Provisions, damage will be sustained by the DISTRICT and that it will be impracticable to determine the actual damage by which the DISTRICT will sustain in the event of and by reason of such delay and it is therefore agreed that the Contractor will pay to the DISTRICT the sum of one thousand two hundred fifty dollars (\$1,250) per day for each and every day's delay beyond the time prescribed to complete the work.

### **2.00 NOT USED**

### **3.00 CONSTRUCTION AREA SIGNS**

The Contractor shall furnish, install, maintain and remove all construction area signs in conformance with the plans and Sections 12-3.06 of the State of California Department of Transportation (Caltrans) Standard Specifications, latest edition.

### **4.00 DUST CONTROL**

Dust control shall be performed in accordance with Subsection 7-8.1, "Clean up and Dust Control," of the Standard Specifications, Imperial County Air Pollution Control District (ICAPCD) Rules 800, 801, 802, 803, the general Provisions and the following Provision.

Dust resulting from the Contractor's performance of the work, either inside or outside, the right-of-way shall be controlled by the Contractor. Dust control includes the action necessary to prevent, reduce or control dust within the work area as required to complete the work. The Contractor shall carry out proper and efficient measures to prevent his operations from producing dust in amounts damaging to property or causing a nuisance or harm to persons living nearby or occupying buildings in the vicinity of the work. The Contractor shall control dust twenty-four (24) hours a day, seven (7) days a week. The methods to be used for controlling dust in the construction area and along haul roads shall be approved by the Engineer prior to starting any work.

Dust or dirt accumulations generated by the Contractor's operations shall be cleaned and removed by the Contractor from all areas as designated by the Engineer. The cost for cleaning and removal of dust or dirt shall be at the Contractor's expense and no additional compensation will be made therefore.

Water for use in dust control shall, at the option of the Contractor, be potable or non-potable. Non-potable water shall consist of reclaimed waste water or non-potable water developed from other sources.

If the Contractor uses reclaimed waste water in the work, the sources and discharge of reclaimed waste water shall meet the California Department of Health Services Water Reclamation Criteria and the Regional Water Quality Control Board requirements. The Contractor shall obtain either a waste water discharge permit or a waiver from the Regional Water Quality Control Board. Copies of permits or waivers from the Regional Water Quality Control Board shall be delivered to the engineer before using reclaimed waste water in the work.

Water shall be applied in the amounts, at the locations, and for the purposes designated in the Special Provision and these Specifications, and as order by the Engineer.

Water for compacting embankment material, sub-base, base and surfacing material and for laying dust, shall be applied by means of pressure-type distributors or pipe lines equipped with a spray system or hoses with nozzles that will ensure a uniform application of water.

All equipment used for the application of water shall be equipped with a positive means of shut-off.

Unless otherwise permitted by the Engineer or unless all the water is applied by means of pipe lines, at least one mobile unit with a minimum capacity of 3700 L (1,000 gallons) shall be available for applying water on the project at all times.

Chemical additives or binder may be used in water for compaction or dust palliative. If such additives are used, furnishing and applying the additives shall be at the Contractor's expense.

The right is reserved by the Engineer to prohibit the use of a particular type of additive, to designate the locations where a particular type of additive may not be used, or to limit the amount of a particular type of additive to be used at certain locations, all if the Engineer has reasonable ground for believing that such use will in any way be detrimental.

The additive or binder shall be either miscible in water or be some form of material that is directly applied to the surface without mixing with water.

Additives or binders that are miscible in water shall be either a resin emulsion, an SS1 type asphaltic emulsion, materials composed essentially of lignin sulfonate or any other binder that is miscible in water in the proportions provided herein is non-corrosive, and is effective as a dust palliative.

Resin emulsion shall be composed of from fifty-seven percent (57%) to sixty-three percent (63%) of semi-liquid petroleum resin and the remainder water to which a suitable emulsifying agent has been added. The resin emulsion shall be readily miscible with water and when diluted with any hard water in the proportions of one (1) part of emulsion to ten (10) parts water shall show no signs of breakdown or separation of the petroleum resin base. Resin emulsion, which has been stored in closed containers at temperatures above freezing for a period up to three (3) months shall show no signs of separation. Any resin emulsion which has been stored for more than three (3) months shall not be used until tested and approved.

SS1 type asphaltic emulsion shall conform to the provisions in Subsection 203-3, "Emulsified Asphalt."

Additives or binders that are miscible in water shall be mixed with additional water at the rate of from four (4) to nineteen (19) parts of water to one (1) part of binder, the exact rate to be determined by the Engineer. Mixing shall be accomplished by placing the binder and water in the spreading equipment simultaneously or by some other mixing method that will produce equivalent results.

The resulting mixture shall be applied with pressure type water distributor trucks equipped with a spray system or pressure type asphalt distributors at an approximate rate of from 0.9- to 3.6 L/m<sup>2</sup>. (0.2 to 0.8 gallon on per square yard)

Additives or binders that are directly applied to the surface without mixing with water shall be applied with equipment approved by the Engineer. The binder shall be applied at a rate of from 0.4- to 1.1L/m<sup>2</sup>. (0.10 to 0.25 gallons per square yard)

The exact rate and number of applications of binders will be determined by the Engineer.

Dust control ordered by the Engineer to be applied on Saturdays, Sundays or holidays

will be included in the Contract price for dust control and no additional compensation will be allowed therefore.

No adjustment of compensation will be made for any increase or decrease in the quantity of dust control required, regardless of the reason for such increase or decrease.

The full compensation for all direct and indirect costs incurred for work performed or materials used to control dust resulting from the Contractor's performance of the work and caused by public traffic, either inside or outside the right-of-way shall be considered as included in the Contract prices paid for the various items of work involved and no additional compensation will be allowed therefore.

5.00 NOT USED

## 6.00 COOPERATION AND COLLATERAL WORK

Cooperation shall be in accordance with Subsection 5-6, "Cooperation," and Subsection 7-7, "Cooperation and Collateral Work," of the Standard Specifications and these Special Provisions.

The Contractor shall be responsible for ascertaining the nature and extent of any simultaneous, collateral and essential work by others and coordinating with the work by others. The DISTRICT, other contractors and utilities shall have the right to operate within or adjacent to the work site during the performance of such work.

Should construction be under way by other forces or by other contractors within or adjacent to the limits of the work specified or should work of any other nature be under way by other forces within or adjacent to those limits, the Contractor shall cooperate with all the other contractors or other forces to the end that any delay or hindrance to their work will be avoided. The right is reserved to perform other or additional work at or near the site (including material sources) at any time, by the use of other forces.

Each contractor shall be responsible to the other for all damage to work, to persons or property caused to the other by their operations, and for loss caused the other due to unnecessary delays or failure to finish the work within the time specified for completion.

**The Contractor shall include in its proposal all costs involved as a result of coordinating its work with others. The Contractor will not be entitled to additional compensation from the DISTRICT for damages resulting from such simultaneous, collateral and essential work. If necessary to avoid or minimize such damage or delay, the Contractor shall re-deploy its work force to other parts of the work.**

Should the Contractor be delayed by the DISTRICT, and such delay could not have been reasonably foreseen or prevented by the Contractor, the Engineer will determine the extent of the delay, the effect on the project and any extension of time. Should any



agency or utility company's work result in delays to the Contractor's work schedule, the Contractor shall be entitled only to an equivalent extension of time for the completion of the contract, and shall not be entitled to damages due to downtime and idled equipment or additional payments over and above the agreed upon unit prices.

Compensation for compliance with all collateral work shall be considered as being included in the various Contract items in the proposal schedule and no additional compensation will be allowed therefore.

7.00 NOT USED

8.00 EXISTING IMPROVEMENTS

The Contractor shall make every effort to protect all existing improvements and facilities from damage during the progress of his/her/its work. No trees, planters, walks, shrubs, signs, fences or other such facilities shall be removed except as shown or called for on the plans or unless specifically authorized in writing by the Engineer. The Contractor shall be held responsible for the care and preservation of the present premises and of adjacent premises and coterminous property. Any parts of them which are injured, damaged or disturbed because of his work shall be repaired, replaced or cleaned by him at his expense.

The Contractor shall apply either water and/or dust palliative for the alleviation or prevention of dust nuisance and damage originating from the Contractor's operation.

8.01 EXISTING UTILITIES

The Contractor will be required to work around public utilities and other improvements that are to remain in place within the construction area. The Contractor will be held liable for any damage to existing improvements or interference with service resulting from his operations. The exact location of underground facilities and improvements within the construction area shall be ascertained by the Contractor before using equipment that may damage such facilities.

9.00 MAINTENANCE CALL-OUTS

Any expense for maintenance call-outs by the DISTRICT's traffic signal maintenance personnel resulting from the Contractor's operations and construction of this project shall be borne by the Contractor.

10.00 WARRANTIES, GUARANTEES AND INSTRUCTION SHEETS:

Warranties, guarantees and instruction sheets shall conform to the provisions in Section 86-1.04, "Warranties, Guarantees and Instruction Sheets" of the State Standard Specifications and these Special Provisions.

Completed work shall be guaranteed to the DISTRICT by the Contractor for a period of not less than twelve (12) months following the date of acceptance thereof. There will be an **11 month inspection**. If any areas are found to need repairs, they will be repaired in a reasonable time frame as warranty work.

Where Contractor-installed equipment and/or facilities are damaged prior to final acceptance by the DISTRICT, the Contractor shall repair or replace such equipment and/or facilities at his expense. The Contractor shall include in his proposal prices for various line items the necessary costs for warranty work. No additional compensation will be made therefore.

#### 11.00 STORAGE OF MATERIAL.

The site of work shall be maintained clean at all times. Excavated material shall be loaded directly and hauled away from job site for disposal at the Contractor's expense. The Contractor shall store material on job site as directed by the DISTRICT or Resident Engineer, and paid as a part of his Contract work.

#### 12.00 CLEANUP OF SITE.

During the progress of the work, the Contractor shall keep the premises occupied by him in a neat, orderly and sanitary condition. He shall dispose of refuse as often as directed, or as may be necessary so that at no time shall there be any accumulation of rubbish, excavated material or equipment that will interfere with convenience or operation of materials so as to provide the minimum obstruction to traffic at all times.

#### 13.00 SANITARY ARRANGEMENTS.

The Contractor shall make provisions for and maintain, in a sanitary manner at the worksite, all necessary and sanitary conveniences for the workers, in accordance with the rules and regulations of the State of California Board of Health and all other local, State and Federal rule and regulations that govern sanitary work conditions.

#### 14.00 ACCESS.

The Contractor's attention is directed to the existing vehicular access ways to the water treatment plant. These access ways shall not be closed unless an alternate access way is provided. The Contractor shall assume full responsibility for providing alternate access. The compensation for the work in this time shall be considered as included in the cost of the various Contract items of work and no additional compensation will be made therefore.

#### 15.00 NOT USED

#### 16.00 MOBILIZATION

Mobilization shall be in accordance with Subsection 9-3.4 "Mobilization," of the Standard Specifications and these special provisions.

Mobilization shall consist of preparatory work and operations, including but not limited to, those necessary for the movement of personnel, equipment, supplies and incidentals to the project site; for the establishment of all offices, buildings, construction yards, sanitary facilities and any other facilities necessary for work on the project; and for all other work and operations which must be performed or costs incurred prior to beginning work on the various contract items on the project site, as well as the related demobilization costs anticipated at the completion of the project. The cost of all bonds and insurance policies, including premiums and incidentals, shall be included in mobilization.

No additional compensation will be allowed for additional mobilizations required, including but not limited to, delays caused by the relocation of existing utility facilities shown on the plans or discovered during construction operations.

The deletion of work or the addition of extra work as provided for herein shall not affect the price paid for Mobilization.

**Payment for mobilization, additional mobilizations, cost of all bonds and insurance policies and all costs incurred prior to beginning work and demobilization at the end of work shall be considered to be included in the mobilization/demobilization line item proposal, and no additional compensation will be allowed.**

17.00. NOT USED  
18.00 NOT USED  
19.00 NOT USED  
19.50 NOT USED

/// END OF SPECIAL PROVISIONS

# TECHNICAL SPECIFICATIONS

## Contents

TECHNICAL SPECIFICATIONS .....	51
SECTION 01505 - MOBILIZATION.....	58
SECTION 01520 - TEMPORARY FACILITIES .....	60
SECTION 01550 - SITE ACCESS AND STORAGE .....	63
SECTION 01560 - PROJECT ENVIRONMENTAL CONTROLS.....	64
SECTION 05500 - MISCELLANEOUS METALS.....	<b>Error! Bookmark not defined.</b>
SECTION 09800 - PROTECTIVE COATINGS.....	<b>Error! Bookmark not defined.</b>
SECTION 13290 - REHABILITATION OF EXISTING STEEL TANK .....	<b>Error! Bookmark not defined.</b>

### 1.01 STANDARD SPECIFICATIONS:

Unless indicated otherwise, the work embraced herein shall be done in accordance with the appropriate provisions of construction details as shown in the specifications entitled “GREENBOOK Standard Specifications for Public Works Construction,” the latest edition, insofar as the same may apply, which specifications are hereinafter referred to as the Standard Specifications and in accordance with the following provisions.

Rehabilitation of the reservoirs work shall be completed per the rehabilitation plans, technical specifications, and latest AWWA D100 standard, latest AWWA D102 Standard, latest AWWA D103 Standard and latest AWWA C652 Standard.

In case of conflict between the Standard Specifications and these General Conditions and Specifications, the General Conditions and Specifications shall take precedence over and be used in lieu of such conflicting portions.

### 1.02 SCOPE OF WORK:

The work is generally described as follows:

The purpose of this project is to replace an existing tank. Although the new tank is larger than the existing tank, the project will result in the reduction of overall capacity, due to the decommissioning of two existing 750,000 gallon tanks (not a part of this construction project). The project includes demolition of the existing tank, onsite piping, excavation and compaction of the tank pad, and installation of a new bolted steel tank.

Eleven months after the substantial completion of the tank, the tank will be drained and an inspection will occur. Any areas of corrosion will be repaired by the Contractor as warranty work.

## TECHNICAL SPECIFICATIONS

### SPECIFICATIONS FOR FACTORY POWDER COATED BOLTED STEEL TANK

#### PART 1 GENERAL

##### 1.01 SCOPE

- A. This specification covers the furnishing of all labor, material, equipment, tools, services and erection of a Factory Powder Coated Bolted Steel water storage tank, as manufactured by Superior Tank Co., Inc., Rancho Cucamonga, CA (or approved equal) and as shown on the plans and specified herein.
- B. The bolted steel tank shall conform to the requirements of American Water Works Association (AWWA) D103-09 Standard for Factory-Coated Bolted Carbon Steel Tanks for Water Storage.

##### 1.02 SUBMITTALS

- A. Shop Drawings: Submit shop drawings of the bolted steel reservoir and all accessories for review and approval by the engineer prior to beginning any related shop fabrication or erection. Include sufficient data to show that the reservoir and accessories conform to the requirements to these Specifications.

Submittals shall include:

1. Design calculations, signed by a civil or structural engineer registered in the State of **California**.
2. Fabrication and erection drawings and details for the reservoir and all accessories.

3. Certified mill tests on steel plate and structural members demonstrating that the physical and chemical requirements of this Specification have been met.

## PART 2 PRODUCTS

### 2.01 GENERAL DESCRIPTION

- A. The Manufacturer shall furnish, erect and test the tank, as required by AWWA.D103-09. The Manufacturer shall be completely responsible for the construction and satisfactory performance of the tank during the guarantee period. The tank shall conform to AWWA 0103-09, to the latest edition Building Code, and to the requirements of the plans and these Specifications. The supplier shall submit for approval complete and detailed plans for the tank and appurtenances.
- B. The Factory Powder Coated, bolted steel tank shall have a nominal capacity of **700,000** gallons (nominal – actual storage is 500,000 gallons with 4 feet of freeboard). It shall have a nominal diameter of **86 feet** and a nominal height of **16 feet**. A cone roof, sloped to drain toward the shell, shall be provided. Provide the reservoir complete with all pipe connections, access openings, nozzles, taps, drains, ladders, vent, and other accessories as shown on the plans or required herein.

### 2.02 DESIGN DATA

- A. The following data and information are supplied as a basis for design and erection of the tank and appurtenances:
  1. Tank Capacity & Dimensions
 

a.	Nominal Capacity	<i>Specify Capacity</i>
b.	Usable Capacity	<i>Specify Capacity</i>
c.	Inside Diameter	<i>Specify Diameter</i>
d.	Tank Height	<i>Specify Height</i>
  2. Seismic Design Criteria
 

a.	Seismic Use Group	<i>Specify Per D103 14.2.1</i>
b.	Seismic Importance Factor, $I_E$	<i>Specify Per D103 14.2.2</i>
c.	Site Class	<i>Specify Per D103 14.2.4</i>
d.	$S_s$	<i>Specify Per D103 14.2.3</i>
e.	$S_1$	<i>Specify Per D103 14.2.3</i>
f.	$F_a$	<i>Specify Per D103 14.2.6</i>
g.	$F_v$	<i>Specify Per D103 14.2.6</i>
  3. Design Wind Loading

- |    |                                 |                                 |
|----|---------------------------------|---------------------------------|
| a. | Design Wind Speed, V            | <i>Specify Per D103 15.1.2</i>  |
| b. | Gust Factor, G                  | <i>Specify Per D103 15.1.1</i>  |
| c. | Importance Factor, I            | <i>Specify Per D103 15.1.1</i>  |
| d. | Exposure Category               | <i>Specify Per D103 15.1.3</i>  |
| 4. | Roof Design Loading             |                                 |
| a. | Roof Live Load                  | <i>Specify Per D103 5.2.3.1</i> |
| b. | Ground Snow Load                | <i>Specify Per D103 5.2.3.2</i> |
| 5. | Liquid to be stored             | Potable water                   |
| 6. | Allowable Soil Bearing Pressure | <i>Specify Bearing Pressure</i> |

## 2.03 MATERIALS

- A. Plates and Sheets. Plates and sheets shall conform to appropriate ASTM designation as set forth in Section 4.4, AWWA D103-09, and shall have a minimum yield strength of 30,000 psi.
- B. Structural Shapes. Structural shapes shall conform to the requirements and ASTM designations of AWWA D103-09 section 4.5
- C. Bolts. Tank joint bolting shall be minimum ½" diameter, shall meet the requirements of AWWA D103-09 section 4.2.1. and have tensile strength of at least 120,000 pounds per square inch.
- D. Gaskets and Sealant. All gaskets and sealants used on this tank shall conform to the requirements of AWWA D103-09 section 4.10.

## 2.04 ACCESSORIES

- A. Shell Manhole: Provide a 24", minimum, hinged shell manhole located as shown on the drawings. The center of the manhole shall be located 30 inches above the bottom of the tank.
- B. Pipe Connections:
  - 1. Provide inlet nozzle, outlet nozzle with antivortex plate {recommended}, and overflow and drain outlets as shown on the plans.

2. Provide a 1-inch NPT tank connection as shown on the plans for sampling connection.
- C. Overflow pipe: Provide steel internal or external overflow pipe, internal weir box, if required, and supports as shown on the plans. Overflow pipe assembly shall be powder epoxy lined and coated for corrosion protection.
- D. Ladders:
1. Provide a galvanized steel welded exterior ladder with backguard as shown on the plans. The ladder shall have a lockable closure at the bottom.
  2. Provide a galvanized steel welded interior ladder. Safe-T-Climb assembly is optional.
- E. Roof Openings:
1. A 20 inch screened vent shall be provided on the roof. The vent shall be fabricated to provide removable screened openings between the vertical support members of the vent. The screened openings of the vent shall be sized by the manufacturer to all venting of a 3,000 gpm pumping rate. An effective area of 75% of screen opening shall be assumed. The screen shall consist of one layer of Type 316 stainless steel: 16 x 16 x 0.018 wire mesh insect screen.
  2. The tank roof shall have a curbed, upward opening 24-inches square, minimum hatch located near the ladder. The curb shall extend at least 4 inches above the tank. The hatch cover shall be hinged and shall have locking provisions. The hatch cover lip shall extend for a distance of 2-inches down on the outside of the curb.
- F. Provide a Superior Tank Model # 2400 (or approved equal), Liquid Level Indicator with Type 316 stainless steel internals and complete with float and target board assembly.
- G. Gaskets and sealants shall meet or exceed AWWA, FDA, and EPA standards for potable water.
- H. Anchor bolts and stirrups, if required, to be furnished by the tank manufacturer.



## **PART 3 EXECUTION**

### **2.04 PROTECTIVE COATING**

- A. General: All metal plates, supports, members and miscellaneous parts, except bolts, shall be Factory Powder Coated in accordance with AWWA D103, Section 12.6 and this Section. Field coating, other than touch-up, will not be permitted.
  
- B. Surface Preparation:
  - 1. All steel surfaces shall be shot blasted to equivalent of a SP 10 or better near white metal finish. The surface anchor pattern shall be no less than 1.5 mils.
  
  - 2. Spray a final Deionized water rinse with Silica-Zirconium (Si-Zr) sealer to prevent rusting prior to the powder coating application and provide additional level of corrosion protection
  
  - 3. All steel surfaces shall drip dry for seven (7) minutes prior to entering the dry off oven for eight (8) minutes at 425 degrees F.
  
- C. Coating:
  - 1. All interior steel surfaces, support members and miscellaneous parts shall receive 5 mils minimum average dry film thickness using *Dupont/Axalta* "Tank Tan" (An NSF 61 Approved, Thermal Set Epoxy Powder Coating).
  
  - 2. All exterior steel surfaces, support members and miscellaneous parts shall receive minimum 2 mils average dry film thickness "Tank Tan" primer under 3 mils minimum average dry film thickness using *Dupont* "Superior Sand" (A Thermal Set TGIC-Polyester Powder Coating), for a total of 5 mils.
  
  - 3. NOTE: Painted, uncoated, or glass lined bolted tanks and FRP tanks are not considered equal

## **3.02 CONSTRUCTION**

- A. Field erection of Factory Powder Coated bolted steel tanks shall be in strict compliance with manufacturer's recommendations and performed by manufacturer's employees or certified erection crew to alleviate any potential disputes in coating quality or erection thereof. Particular care shall be exercised in handling and bolting of the tank plates, supports, and members to avoid abrasion or scratching the coating. Prior to placing water in the tank, a "holiday" inspection of the entire tank, corners included, will be provided and performed by the manufacturer in the presence of the owner. Touch-up coating shall be done per the manufacturer's recommendations where needed and as directed to achieve 100% holiday-free surface.

### **3.03 TESTING AND INSPECTION**

- A. General: Test storage tank after erection. Floor shall be clean and free from dirt, foreign substance and debris.
- B. Bottom: Vacuum test seams in floor plates.
- C. Shell: Test by filling with water to elevation of overflow. Completed storage tank shall show no leaks at end of 24 hour test period. No charge will be made for water required to fill tank.
- D. Disinfection:
  - 1. General: After testing has been satisfactorily completed, tank shall be disinfected.
  - 2. Standards: Disinfecting of interior surfaces shall be performed in accordance with AWWA C652-86. After disinfection, the Owner shall take a water specimen for bacteriological test, as prescribed at Code 40 of the Federal Regulations, Sections 141.21 through 141.30, 141.41 and 141.42.
  - 3. After disinfection, the tank shall be filled to the overflow level and allowed to stand for 5 days, minimum. After 5 days, the Owner shall take water specimens for V.O.C. test per EPA 502.2. The tank may be placed into service once acceptable test results are received.

### **3.04 WARRANTY**

- A. The tank manufacturer, shall warrant the tank against any defects in workmanship and materials for a period of one (1) year from the date of shipment. In the event any such defect should appear, it should be reported in writing to the manufacture during the warranty period.

### **3.05 FOUNDATION**

- A. Tank foundation shall be granular berm with steel retainer ring per AWWA D103-09 section 13.4.5.

**END OF SECTION**

**Rev: 11/5/15**

## SECTION 01505 - MOBILIZATION

### PART 1 - GENERAL

#### 1.01 DESCRIPTION

A. Mobilization shall include obtaining all permits; moving plant equipment on-site; furnishing and erecting plants, temporary buildings and other construction facilities; all as required for the proper performance and completion of the Work. Mobilization shall include, but not be limited to, the following principal items:

1. Moving on to the site of all Contractors' plant, equipment and materials required for first month operations.
2. Installing temporary construction power, wiring and lighting facilities.
3. Establishing fire protection equipment and instructing designated personnel in the operation of such apparatus.
4. Providing field office trailer for the Contractor complete with furnishings and utility services when applicable. Contractor will furnish the temporary power, water, telephone, copier, facsimile machine and other items for the Contractor's field offices. Contractor to furnish and install necessary piping, wiring and disconnects.
5. Providing all on-site Contractor communication facilities.
6. Providing on-site Contractor's sanitary facilities.
7. Arranging and setting up the Contractor's work and storage yard.
8. Obtaining all required permits.
9. Posting all OSHA required notices and establishment of safety programs.
10. Have Contractor's superintendent at the jobsite full time.
11. Submittal of Construction Schedule.
12. Install project sign, if required.
13. Submittal of Schedule of Values.
14. Costs of Insurance, Payment Bond, Performance Bond, Taxes, Permits, Freight and similar expenses.

## 1.02 PAYMENT FOR MOBILIZATION

- A. A Mobilization Item is included in the Proposal forms. The Mobilization payment shall not be released to the Contractor unless all items in Paragraph "A" above have been satisfied.

END OF SECTION 01505

## SECTION 01520 - TEMPORARY FACILITIES

### PART 1 – GENERAL

#### 1.01 DESCRIPTION

Except as otherwise provided, the Owner shall bear no costs of temporary facilities or their removal. It shall be the Contractor's responsibility to provide equipment that is adequate for the performance of the Work under this contract within the time specified. All equipment shall be kept in satisfactory operating condition, shall be capable of safely and efficiently performing the required Work and shall be subject to inspection and approval by the Owner's representative at any time within the duration of the Contract. All work hereunder shall conform to the applicable requirements of the OSHA Standards for Construction.

#### 1.02 TEMPORARY POWER AND LIGHTING SERVICES

The Contractor shall provide all necessary temporary power connection, disconnects and distribution lines required for its operations under the Contract and shall provide and maintain all temporary power systems required to perform the Work in a safe and satisfactory manner. The Contractor shall make the arrangements with the SDG&E and pay all fees, and shall bear all costs for these temporary services and shall furnish and install all necessary transformers; metering facilities and distribution centers from branch circuits as may be required.

All temporary connections for electricity shall be subject to approval of the Engineer and shall be completely removed at the Contractor's expense prior to final acceptance of the Work. All wiring for temporary electric light and power shall be properly installed and maintained and shall be securely fastened in place. All electrical facilities shall conform to the requirements of the OSHA Safety and Health Standards for Construction and the governing agency and electrical purveyor.

The Contractor shall provide lighting and outlets in temporary structures throughout the project as may be required for safety, proper performance and inspection of the Work. If operations are performed during hours of darkness, or if natural lighting is deemed insufficient by Engineer, the Contractor shall provide adequate floodlights, clusters and spot illumination. The use of permanently installed lighting fixtures, lamps and tubes for work shall not be permitted except by special permission of Engineer. The Contractor shall make arrangements with Subcontractors for electrical services and lighting as may be necessary in the performance of their work.

### 1.03 TEMPORARY WATER SERVICES

- A. General: Unless specifically specified for a specific scope of work or construction activity, the Owner shall furnish water for all testing and construction purposes. Utility water may be used for hydraulic structures and pipeline testing as approved by the Engineer and DISTRICT.

Temporary water service lines, if required, shall be installed and removed by the Contractor, who shall pay all charges for making the connections, running the temporary lines, removing the temporary lines at the completion of the Work and disconnecting the services. All relocations required to clear the work of others shall be performed by the Contractor when requested by the Owner.

- B. Potable Water: All drinking water on the site during construction shall be furnished by the Contractor and shall be bottled water or water furnished in approved dispensers. Notices shall be posted conspicuously throughout the site warning the Contractor's personnel that piped water for construction purposes may be contaminated and is not for human consumption.
- C. Water Connections: The Contractor shall not make connection to, or draw water from, any fire hydrant or pipeline without first obtaining permission of the authority having jurisdiction over the use of said fire hydrant or pipeline and from the agency owning the water system. For each such connection made the Contractor shall first attach to the fire hydrant or pipeline a valve, backflow preventer and a meter, if required by the said authority, of a size and type acceptable to said authority and agency.
- D. Removal of Water Connections: Before final acceptance of the Work all temporary water connections and piping installed by the Contractor shall be entirely removed, and all affected improvements shall be restored to their original condition, or better, to the satisfaction of the Engineer and to the agency owning the affected utility.
- E. Fire Protection: The Contractor shall provide fire extinguishers and other fire protection equipment to adequately protect new and existing facilities and temporary facilities against damage by fire. Hose connections and hose, water casks, chemical equipment or other sufficient means shall be provided for fighting fires in the new, existing and temporary structures and other portions of the Work and responsible persons shall be designed and instructed in the operation of such fire apparatus so as to prevent or minimize the hazard of fire. The Contractor's fire protection program shall conform to the requirements of the OSHA Standards for Construction. The Contractor shall employ every reasonable means to prevent the hazard of fire.

#### 1.04 TEMPORARY STRUCTURES

Prior to starting work, the Contractor shall, as directed by Engineer, provide and maintain suitable temporary office facilities for the duration of the Project as required for the Contractor's project administration; and all necessary sheds and facilities for the proper storage of tools, materials and equipment employed in the performance of the Work.

#### 1.05 CONTRACTOR'S WORK AND STAGING AREA

The Owner shall designate and arrange for the Contractor's use, a portion of the property adjacent to the Work for its exclusive use during the term of the Contract as an office, storage and shop area for its construction operations relative to this Contract. Contractor shall be solely responsible for the security of its tools, supplies and equipment at the site.

#### 1.06 SANITATION

- A. Restroom Facilities: The Contractor shall provide and maintain a portable men's restroom facility and a separate portable women's restroom facility. The restroom facilities shall be placed at the job site prior to the start of construction within ten (10) days from the issuance of the Notice to Proceed and shall remain in service until the job has been completed. The Contractor shall position the restroom facilities, as required to maintain the facilities, near the location of daily work activity-and-near-the-Construction Office—Trailer. The restroom facilities shall be cleaned on a regular basis.
- B. Sanitary and Other Organic Wastes: The Contractor shall establish adequate and regular collection of all sanitary and organic wastes. All wastes and refuse from sanitary facilities provided by the Contractor or organic material wastes from any other source related to the Contractor's operations shall be disposed of in a manner satisfactory to the Engineer and in accordance with all laws and regulations pertaining thereto. Contractor may install temporary piping for toilet facilities to discharge into an incoming sewer.

#### 1.07 COMMUNICATIONS

- A. Telephone Services: The Contractor shall provide its own phone lines. The Owner's telephone system shall not be used by the Contractor's work force.
- B. Facsimile Services: The Contractor shall provide its own facsimile unit(s). The costs relative to the facsimile unit(s) shall be borne by the Contractor.



## 1.08 FENCE AND BARRICADES

The Contractor shall provide such protective fences and barricades as he/she may deem necessary for public safety and to protect his/her storage areas and the Work in place. The location and appearance of all fences shall be subject to approval of the Engineer.

## 1.09 CONTRACTOR PARKING

The Contractor shall not park his/her equipment, nor allow his/her personnel to park, in any area except those specifically designated by the Engineer.

## 1.10 TEMPORARY LIVING QUARTERS

Temporary living quarters shall not be allowed on the job site or on publicly-owned properties. In addition, all local zoning codes for the area in question shall be strictly adhered to.

## 1.11 REMOVAL OF TEMPORARY CONSTRUCTION

The Contractor shall remove temporary office facilities, toilets, storage sheds and other temporary construction from the site as soon as, in Engineer's opinion, the progress of work permits. Contractor shall recondition and restore those portions of the site occupied by the same to a condition equal to or better than it was prior to construction.

END OF SECTION 01520

## SECTION 01550 - SITE ACCESS AND STORAGE

### PART 1 – GENERAL

#### 1.01 HIGHWAY AND STREET LIMITATIONS

- A. The Contractor shall make its own investigation of the condition of available public and private roads and of clearances, restrictions, bridge load limits and other limitations affecting transportation and ingress and egress to the site of the Work. It shall be the Contractor's responsibility to construct and maintain any haul roads required for its construction operations or define any alternate routes to the project site due to roadway or bridge restrictions.
- B. Nothing herein shall be construed to entitle the Contractor to the exclusive use of any public street, utility right-of-way or the site of the Work during the performance of the Work hereunder. The Contractor shall conduct its operations so as not to interfere unnecessarily with the authorized work of utility companies, other agencies, or the Owner's plant personnel. No street or access

shall be closed without first obtaining permission of the Engineer or proper governmental authority. Where excavation is being performed in primary streets or highways one (1) lane in each direction shall be kept open to traffic at all times unless otherwise provided or shown by the Contract Documents. Fire hydrants on or adjacent to the Work shall be kept accessible to fire-fighting equipment at all times. Temporary provisions shall be made by the Contractor to assure the use of sidewalks, access routes and the proper functioning of all gutters, sewer inlets and other drainage facilities.

- C. Traffic Control: For the protection of traffic in public streets and plant operating personnel at the site of the Work, the Contractor shall provide, place and maintain all necessary barricades, traffic cones, warning signs, lights and other approved safety devices. All barricades, traffic cones, warning signs, lights and other approved safety devices shall be placed according to the agency requirements maintaining jurisdiction, as applicable. The Contractor shall take all necessary precautions for the protection of the Work and the safety of the Owner's personnel and the public. All barricades and obstructions shall be illuminated at night.

END OF SECTION 01550

## SECTION 01560 - PROJECT ENVIRONMENTAL CONTROLS

### PART 1 - GENERAL

#### EXPLOSIVES AND BLASTING

The use or storage of explosives on the Work or site shall not be permitted. As construction activities only include the replacement of an existing tank with no additional system capacity, an Environmental Assessment (EA) or Environmental Review is not deemed necessary for this project.

#### 1.02 DUST ABATEMENT AND RUBBISH CONTROL

The Contractor shall provide under the Contract all necessary measures to prevent its operation from producing dust or air contaminants in amounts damaging to property or causing a nuisance to Owner's plant personnel and operations or to persons living in or occupying buildings in the vicinity. The Contractor shall be responsible for damage resulting from any dust and/or air contaminants originating from its operations. The dust and/or air contaminants abatement measures shall be continued throughout the length of the Contract.

During the progress of the Work the Contractor shall keep the site of the Work and other areas used by it in a neat and clean condition and free from any accumulation of rubbish. The Contractor shall dispose of all rubbish and waste materials of any nature occurring at the Work site, and shall establish regular intervals of collection and disposal

of such materials- and waste.- The Contractor shall also keep its haul roads free from dirt, rubbish and unnecessary obstructions resulting from its operations. Disposal of all rubbish and surplus materials shall be off the site of construction in accordance with local codes and ordinances governing locations and methods of disposal and in conformance with all applicable Safety Laws and Health Standards for Construction. The Owner's dumpster shall not be used by the Contractor.

## 1.02 CHEMICALS

- B. All chemicals used during project construction or furnished for project operation, whether soil sterilant, herbicide, pesticide, disinfectant, polymer, reactant or of other classification, shall show approval for use by either the U.S. Environmental Protection Agency, the U.S. Department of Agriculture or the local jurisdictional agency. Use of all such chemicals and disposal of residues shall be in strict accordance with the printed instructions of the manufacturer.

## SECTION 01600 - MATERIALS AND EQUIPMENT PART 1 GENERAL

### 1.01 QUALITY ASSURANCE

- A. To the greatest extent possible for each unit of work, the Contractor shall provide products, materials or equipment from a single source.
- B. Where more than one choice is available as options for Contractor's selection of a product, material or equipment, the Contractor shall select an option which is compatible with other products, materials or equipment already selected.

### 1.02 PRODUCT DELIVERY, STORAGE AND HANDLING

- A. The Contractor shall transport, deliver, handle and store products in accordance with supplier's written recommendations and by methods and means which will prevent damage, deterioration and loss including theft. Delivery schedules shall be coordinated to minimize long-term storage of products at the Work site and overcrowding of construction spaces. The Contractor shall provide installation coordination to ensure minimum storage times for products recognized to be flammable, hazardous or easily damaged.
- B. Products shall be delivered in a dry, undamaged condition in the supplier's unopened packaging. The Engineer and Owner reserve the right to reject all damaged products, materials and equipment. Rejected products shall be immediately removed from the site of the Work.
- C. Products, materials and equipment shall be stored in accordance with the manufacturer's written instructions, with seals and labels intact and legible. Motors, electrical gear, mechanical equipment with open bearings or moving parts or any product sensitive to the environment shall be stored in weather-

tight enclosures with necessary temperature and humidity ranges maintained within the manufacturer's instructions.

- D. Fabricated structural components shall be stored on supports above ground and in a manner to prevent accumulation of water and warping. Products subject to deterioration from atmospheric conditions shall be covered in a manner that will provide adequate ventilation to avoid condensation.
- E. Products, materials and equipment not stored in a manner that will insure the maintaining of a new condition will be rejected by the Engineer. Such rejected products, materials and equipment shall be immediately removed from the Work site.

### 1.03 SOAKING PERIOD AND TESTING FOR VOLATILE ORGANIC COMPOUNDS IN POTABLE WATER RESERVOIRS

- A. General: The Contractor shall provide the following services to ensure that the interior reservoir coatings or linings do not convey volatile organic compounds to the potable water.
- B. Selection of Coating or Lining Material: The Contractor shall provide a coating or lining system that has a successful record in meeting the national, regional, and local regulations and policies pertaining to leaching of volatile organic compounds into potable water.
- C. Before the coating or lining materials are used, the Contractor shall by letter notify the regulatory agency having jurisdiction. The letter shall describe the proposed materials, including brand names, catalog numbers, catalog technical data, application and curing instructions, and material safety data sheets.
- D. The Contractor shall provide curing time, temperature and ventilations as specified by the manufacturer or this Section, whichever is the highest requirement. In some cases, the Contractor may find it necessary to extend the curing time or ventilation time beyond the requirements in order to comply with the regulatory agency requirements or to reduce the leached organic compounds to the required levels. All costs in connection with any extended curing times shall be borne by the Contractor.
- E. Following the curing or ventilation period, the Contractor shall clean, disinfect and fill the reservoir to the overflow level.
- F. A seven (7) day soaking period shall follow the initial filling to determine the presence of any leached organics. If Bacteriological test is negative, then VOC testing time may be completed in conjunction. Before the tank is

placed into service, samples of the water in the tank shall be taken by the Contractor, under the direct supervision of the Owner, and analyzed by a laboratory approved by the State or the EPA. Analyses shall be for volatile organic compounds by EPA Method 524.2 or equivalent (this test includes TCE, PCE, xylenes, toluene, ketones, carbon tetrachloride, similar compounds, or other organic chemicals from MSDS sheets). The costs of testing shall be borne by the Contractor.

- G. If the tests results are above the CDPH's Maximum Contaminant Level Limits, the Contractor shall drain the water from the tank and flush, refill, and retest at no additional cost to the Owner. The Contractor shall provide as many curing, soaking, and flushing cycles as necessary to reduce the leached volatile organic compounds to levels below the requirements.
- H. The Owner will evaluate and determine acceptability as a condition of final acceptance of the work. Acceptance criteria will be in conformance with state and federal regulations.

#### 1.04 TESTING FOR VOLATILE ORGANICS

- A. After successful completion of the Disinfection and Bacteriological Testing, the Contractor shall complete Volatile Organic Compound Testing per section 3.11 of the Technical Specification Section 09800 - PROTECTIVE COATINGS.

#### 1.05 DISPOSAL OF TEST WATER

- A. Water used for testing and disinfection procedures shall be disposed of as required by the Contractor. The Contractor shall identify the point at which the water is to be disposed and provide all pumps, suction hoses, discharge hoses, fuel and labor to dispose of the test water.
- B.

#### 1.06 PLACING TANK IN SERVICE

- A. The tank shall be placed in service after successful disinfection and volatile organic compound testing has been completed and after the Engineer determines that all rehabilitation and coating work has been satisfactorily completed.

END OF SECTION 13290

#### 1.04 BOLTED STEEL TANK ONE (1) YEAR INSPECTION

- A. At the time of tank acceptance for service, the Owner/Engineer shall schedule the first anniversary inspection provided for in AWWA D102. The inspection of

the tank shall be scheduled for a date between the first day of the eleventh month and the thirtieth day of the thirteenth month following acceptance. This schedule for the inspection shall be considered tentative and the Contractor will be notified of the inspection schedule no later than the first day of the tenth month following acceptance of the tank. In scheduling this inspection, the Contractor shall notify the tank manufacturer and the coating Sub-Contractor.

- B. Upon completion of this inspection, the inspecting firm will prepare a report that includes but is not limited to, the methods used in the inspection, the equipment and personnel on hand at the time of the inspection, a summary of findings, photographs of all deficiencies found, and any other information relevant to the condition and maintenance of the tank.
- C. The Contractor shall have a representative on site at the time of inspection to authorize any minor repairs the inspection subcontractor is willing to perform during or directly after the inspection.

PROJECT VICINITY MAP IN BORREGO SPRINGS, CALIFORNIA:

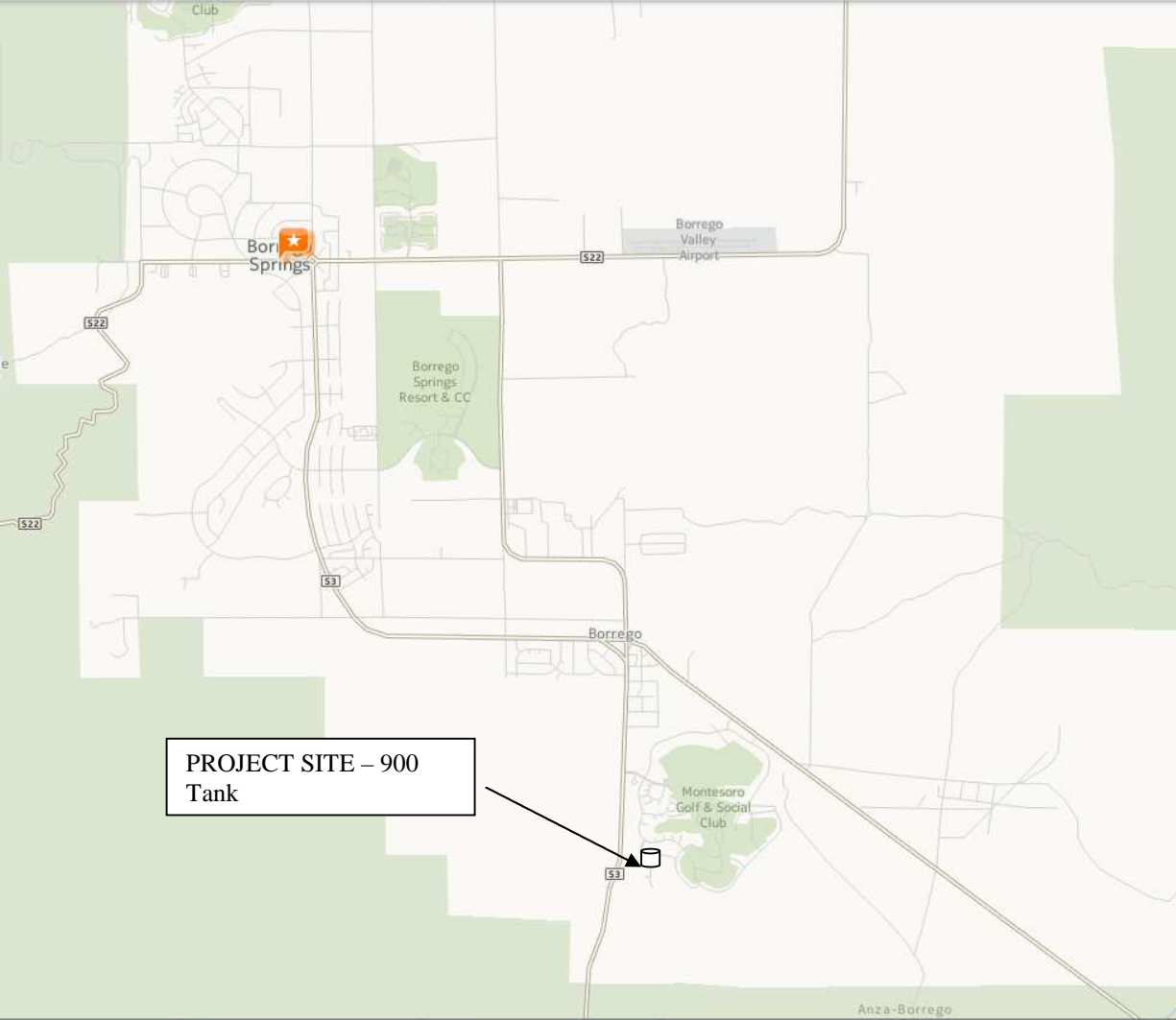

CONTINUED FROM SHEET 14

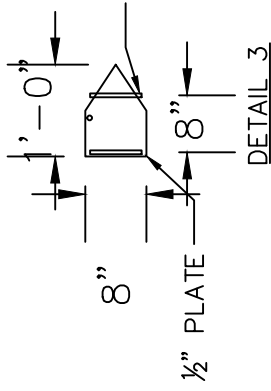
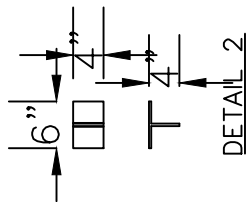
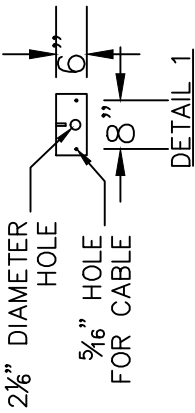

(2) 1/2" DIAMETER X 6" LONG PIPE. FLARE BOTH ENDS.

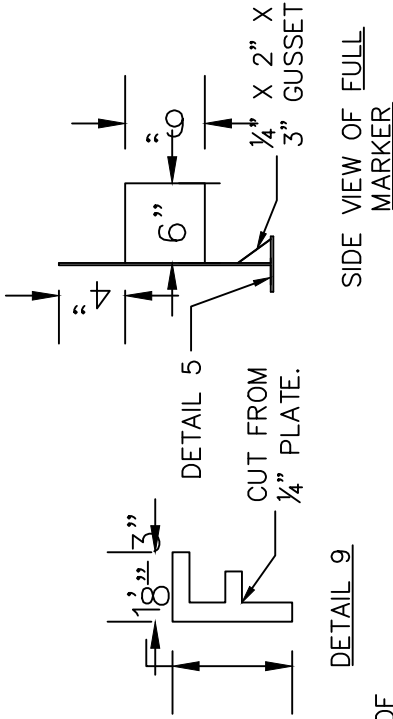
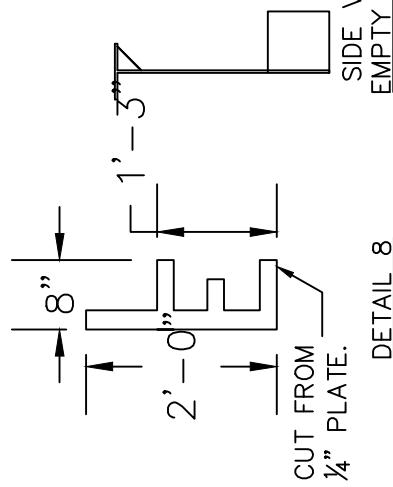
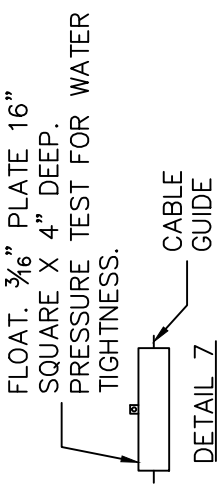
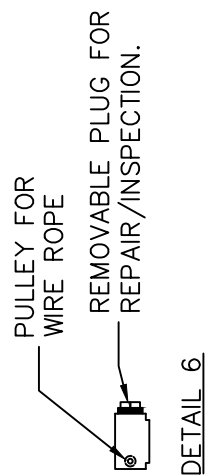
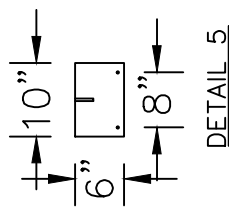
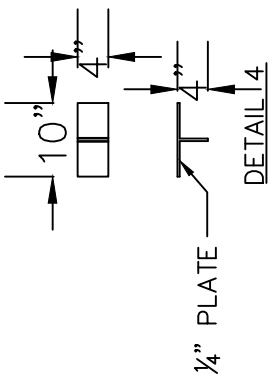

NOTE:  
THE CONTRACTOR SHALL BE RESPONSIBLE FOR THE REMOVAL AND REPLACEMENT OF THE EXISTING LIQUID LEVEL GAUGE ASSEMBLY

900 TANK REPLACEMENT  
LIQUID LEVEL DETAIL

BORRERO WATER DISTRICT		DATE:
CLIENT : BORRERO WATER DISTRICT		BY:
SHEET: 17	OF: 17	

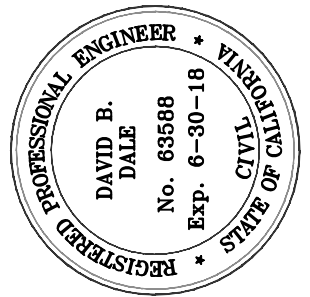

*David Dale*

3/11/2017



EXISTING KEYNOTES

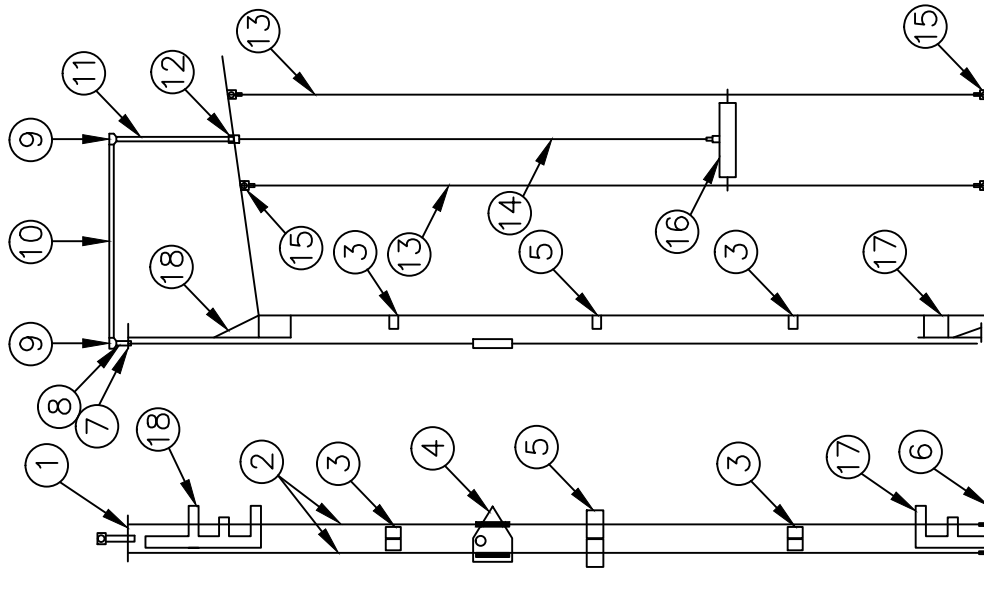

- ① 1/4" THICK TOP PLATE. SEE DETAIL 1.
- ② 1/4" GALVANIZED WIRE ROPE TARGET GUIDES 29' LONG WITH CABLE CLAMPS FOR EACH END.
- ③ QUARTER MARKER - 1/4" THICK WITH 1/4"X4"X4" STAND-OFF. SEE DETAIL 2.
- ④ 1/2" THICK TARGET. SEE DETAIL 3.
- ⑤ HALF MARKER - 1/4" THICK WITH 1/4"X4"X4" STAND-OFF. SEE DETAIL 4.
- ⑥ 1/4" THICK BOTTOM PLATE. SEE DETAIL 5.
- ⑦ PIPE LOCK NUTS TO TIGHTEN AGAINST TOP PLATE.
- ⑧ 1 1/2" DIAMETER GALVANIZED PIPE NIPPLE X 5" LONG.
- ⑨ PULLY BOX FABRICATED FROM 1 1/2" GALVANIZED PIPE TEE WITH PULLY AND SPACER INSIDE. SEE DETAIL 6.
- ⑩ 1 1/2" DIAMETER GALVANIZED PIPE NIPPLE X 40 1/2" LONG.
- ⑪ 1 1/2" DIAMETER GALVANIZED PIPE NIPPLE X 18" LONG.
- ⑫ 1 1/2" FORGED THREAD COUPLING WELDED IN ROOF.
- ⑬ 1/4" GALVANIZED WIRE ROPE FLOAT GUIDES 28' LONG WITH CABLE CLAMP AT EACH END. ATTACHED TO CLIPS.
- ⑭ 1/8" GALVANIZED WIRE ROPE FOR FLOAT/TARGET. 34' LONG WITH CABLE CLAMPS AT EACH END.
- ⑮ 1/4" X 2" SQUARE CLIPS WITH 1" HOLE IN CENTER. WELD TO FLOOR AND ROOF FOR CABLE.
- ⑯ 16" SQUARE X 4" FLOAT X 3/16" THICK PLATE. SEE DETAIL 7.
- ⑰ 1/4" THICK EMPTY MARKER PLATE. SEE DETAIL 8.
- ⑱ 1/4" THICK FULL MARKER PLATE. SEE DETAIL 9.

NOT TO SCALE

CONTINUED ON SHEET 15

\* NOTE: SOME MANUFACTURER'S MAY HAVE DIFFERENT DETAIL FOR LIQUID LEVEL INDICATOR. THIS DETAIL IS TO PROVIDE GUIDANCE FOR TANK MANUFACTURER SUBMITTAL.

*David Dale*

3/11/2017

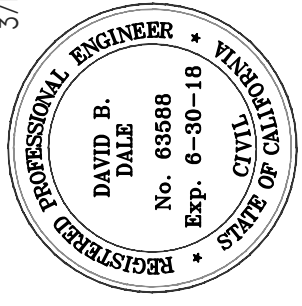

<b>900 TANK REPLACEMENT</b>	SHEET: <b>16</b>	OF: <b>17</b>
	DATE: 12/5/16 BY: DB	
CLIENT : BORREGO WATER DISTRICT		
<b>LIQUID LEVEL DETAIL</b>		

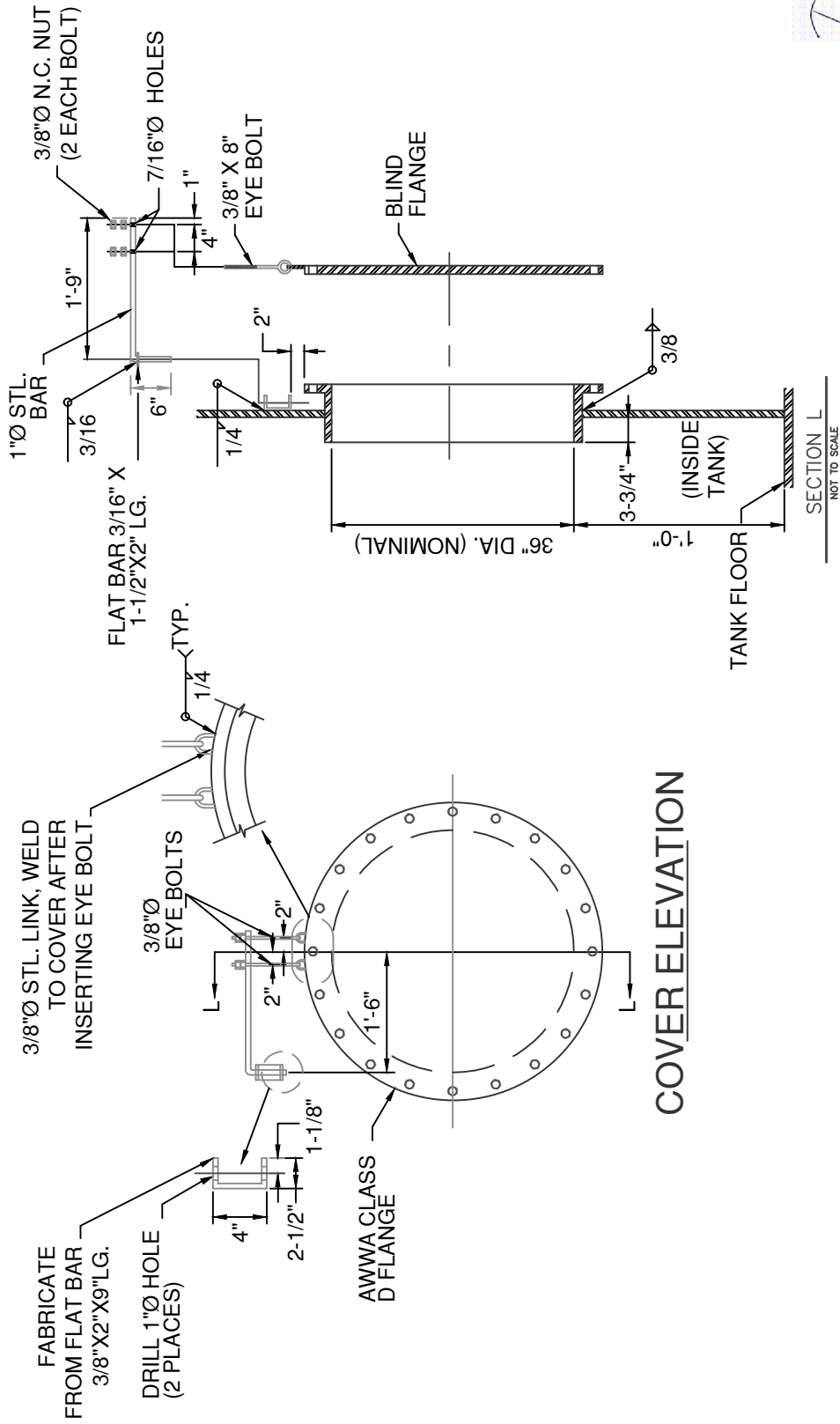

**1** ACCESS MANWAY DETAIL **15**

NOT TO SCALE

*David Dale*

3/11/2017

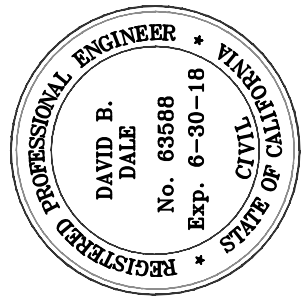

900 TANK REPLACEMENT	SHEET: <b>15</b>	BY: DB
	OF: 17	
MANHOLE DETAIL	DATE: 1/26/15	
	CLIENT: BORREGO WATER DISTRICT	

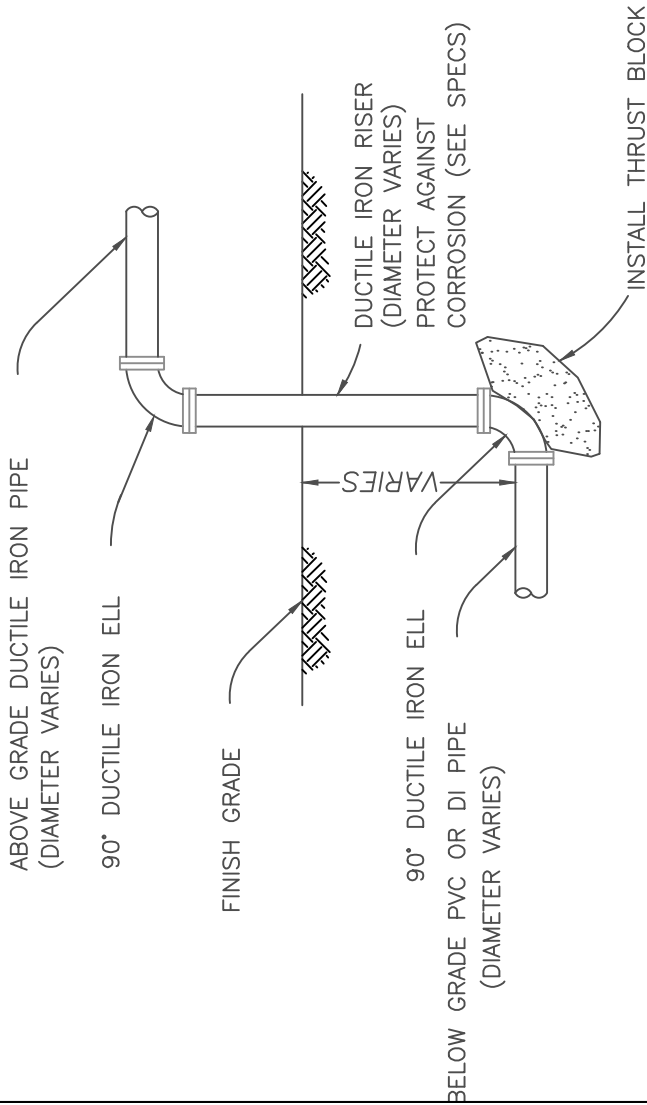

**H** DUCTILE IRON ELLS AND RISER DETAIL

NOT TO SCALE

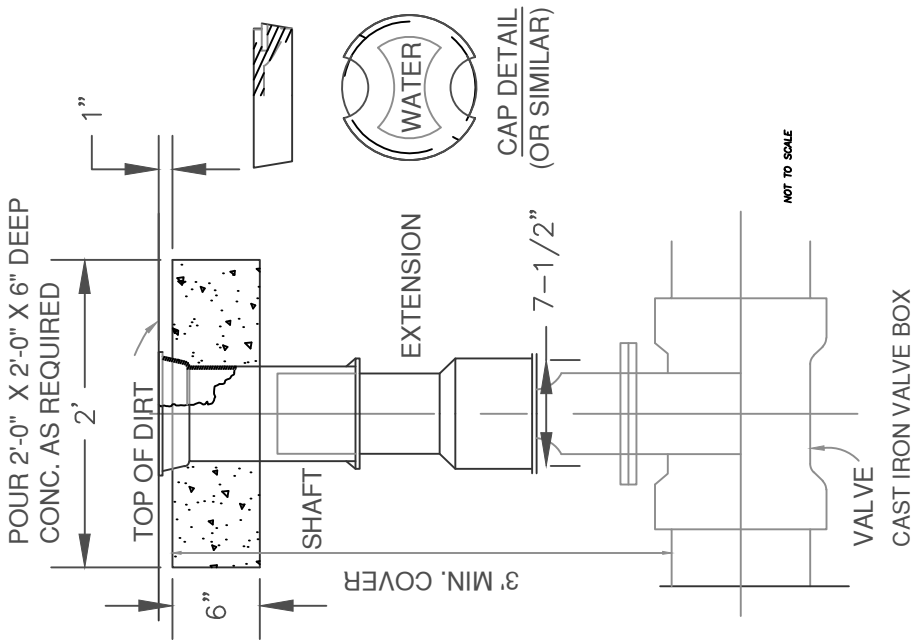
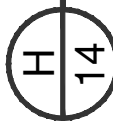

**J** VALVE BOX AND COVER ASSEMBLY

NOT TO SCALE

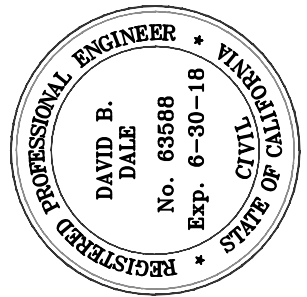

*David Dale*

3/11/2017

145	900 TANK REPLACEMENT	SHEET: <b>14</b>
	TANK PIPING	OF: <b>17</b>
CLIENT : BORREGO WATER DISTRICT		DATE: 1/26/15
		BY: DB

'U' BOLT PIPE SUPPORT  
GRINNEL FIG 259  
OR EQUAL

150 LB THREADED  
REDUCING FLANGE,  
GALVANIZED

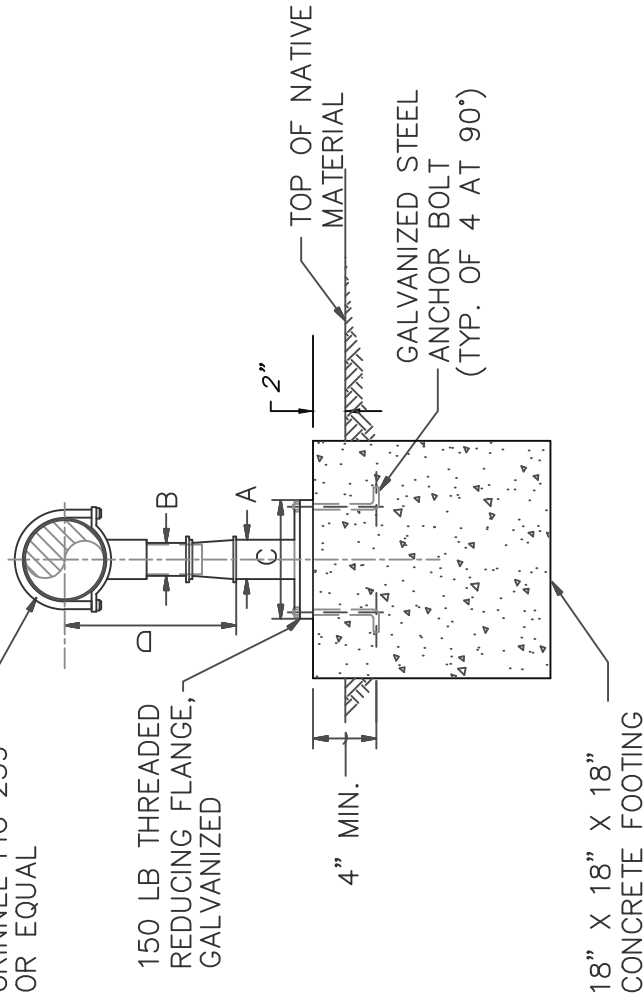

**G** ADJUSTABLE PIPE SUPPORT  
WITH 'U' BOLT  
NO SCALE

ADJUSTABLE PIPE SUPPORT  
IN INCHES

A	B	C	D MIN.	D MAX.
3	2-1/2	9	11-5/8	15-3/4

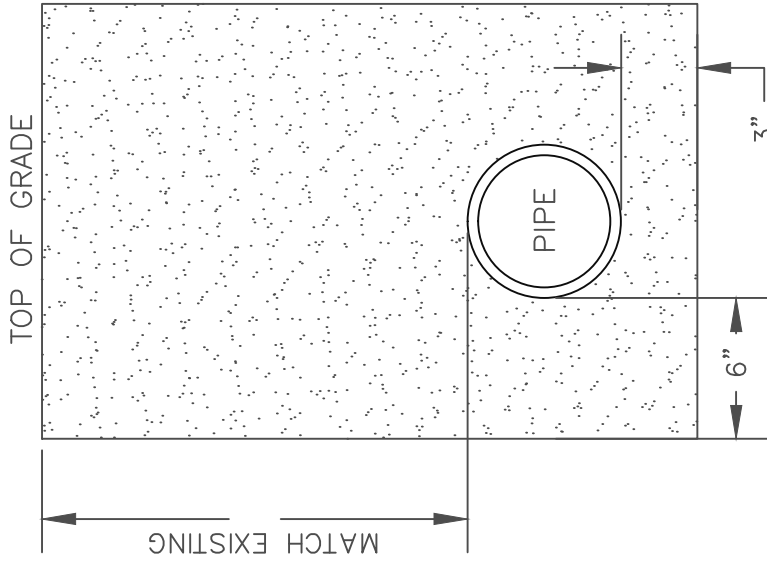

BACKFILL WITH NATIVE SOIL-REMOVE ANY  
ROCKS GREATER THAN 1" COMPACT NATIVE  
SOIL TO 85% MAX DENSITY.

**L** TRENCH DETAIL  
13 NOT TO SCALE

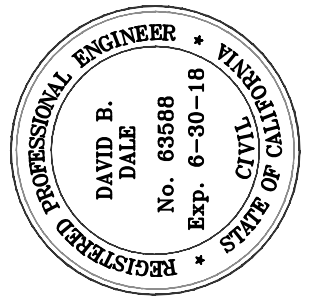

*Dave Dale*

3/11/2017

146	900 TANK REPLACEMENT	SHEET: <b>13</b>	DATE: 1/26/15	BY: DB
		OF: 17	CLIENT : BORREGO WATER DISTRICT	
TANK PIPING				

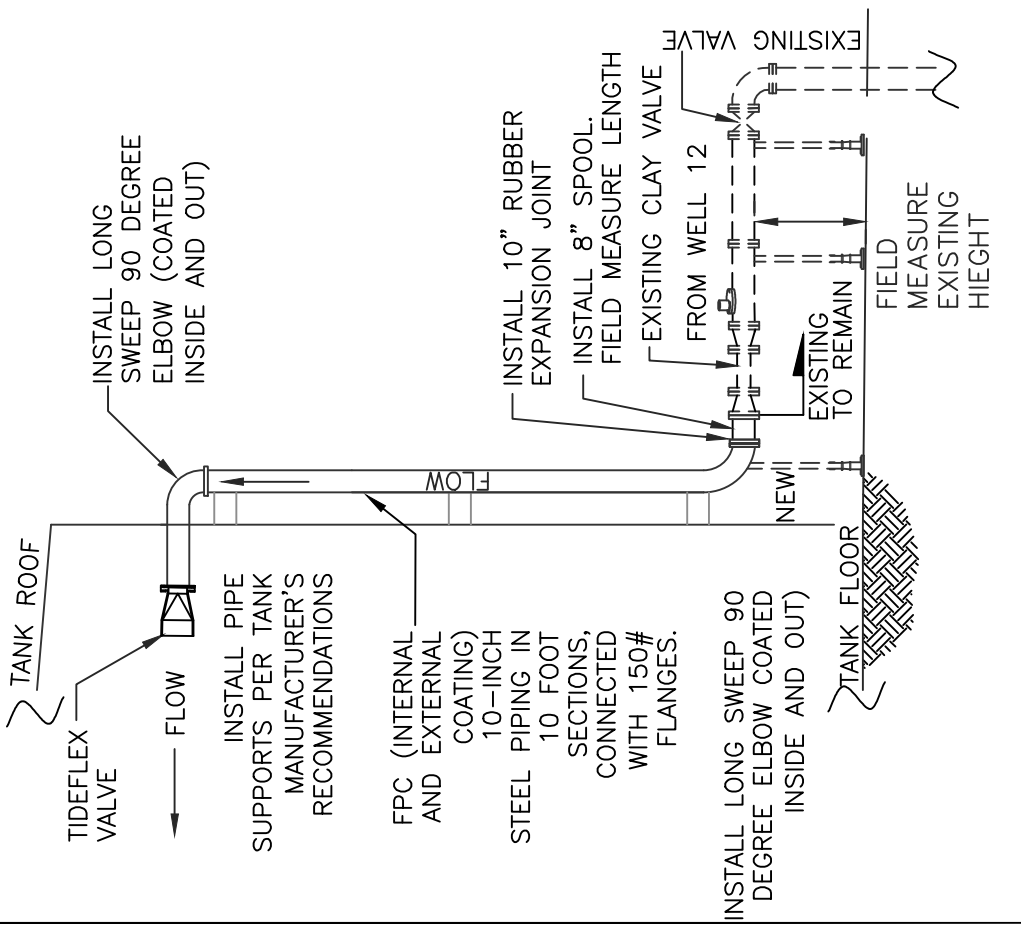

**E**  
12

8" TANK INLET PIPING DETAIL  
NOT TO SCALE

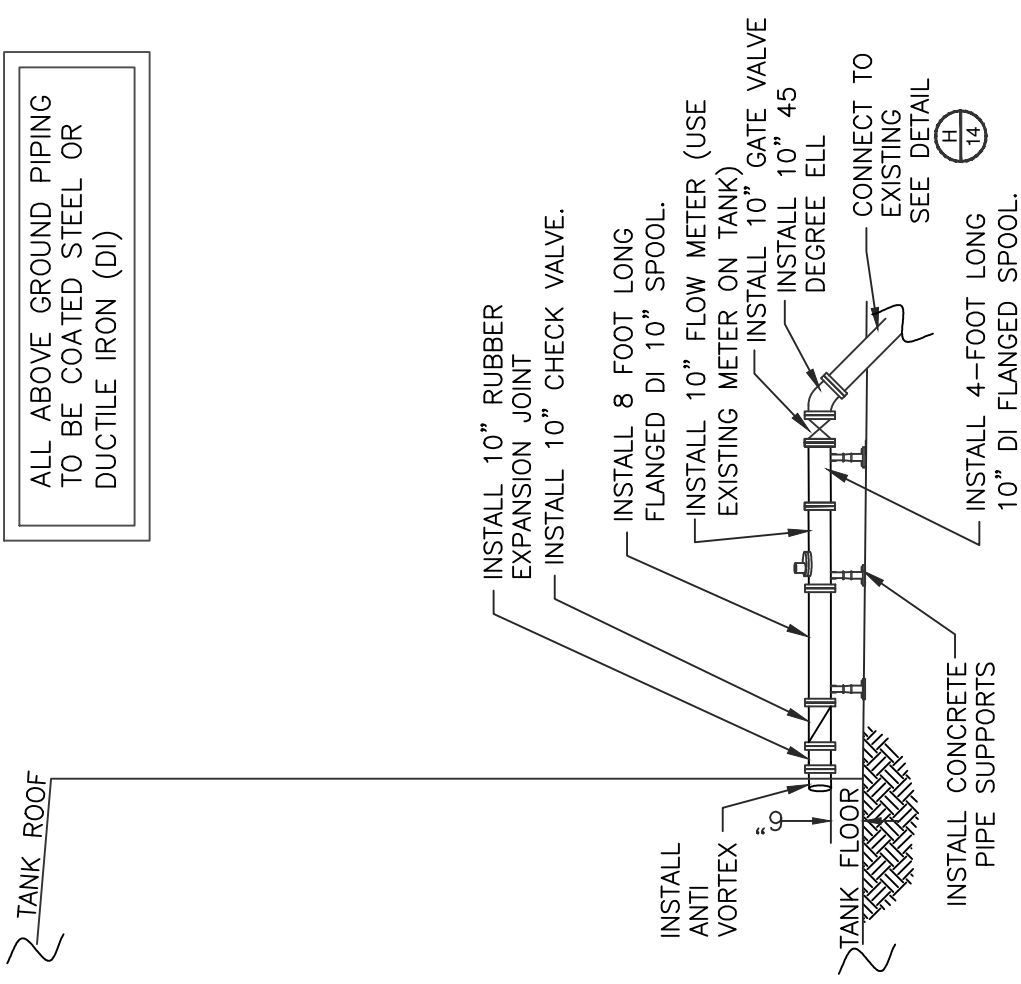

**F**  
12

8" TANK OUTLET PIPING DETAIL  
NOT TO SCALE

ALL ABOVE GROUND PIPING  
TO BE COATED STEEL OR  
DUCTILE IRON (DI)

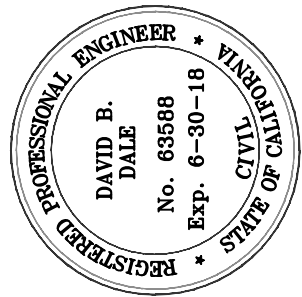

*David Dale*

3/11/2017

147	900 TANK REPLACEMENT	SHEET: <b>12</b>	BY: DB
		OF: 17	
TANK PIPING		DATE: 12/15/16	
		CLIENT : BORREGO WATER DISTRICT	

ALL ABOVE GROUND PIPING TO BE COATED STEEL OR DUCTILE IRON (DI) SEE TOP VIEW DETAIL

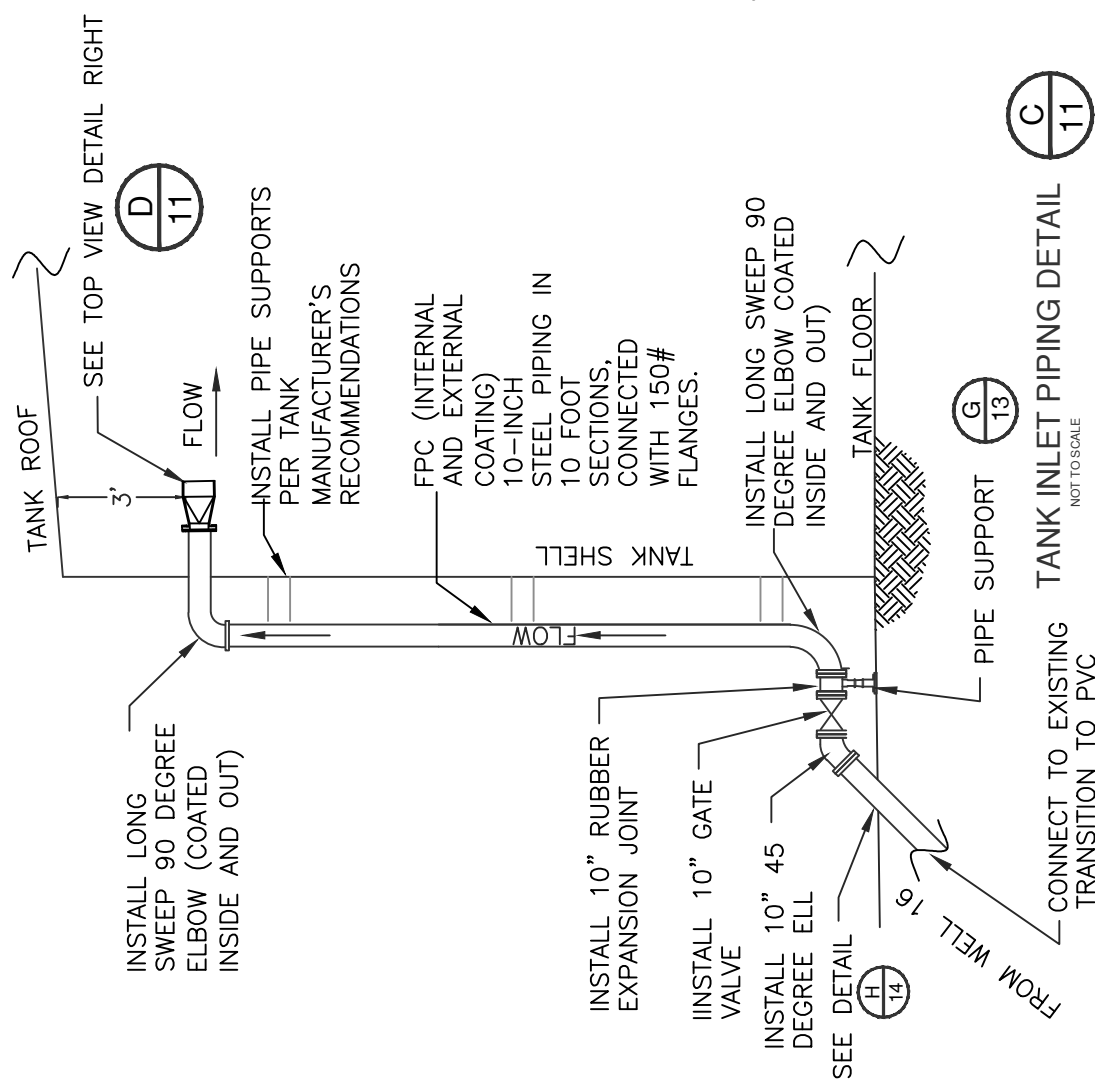

INSTALL DEGR

D/11

TOP VIEW OF INLET INTERIOR PIPING

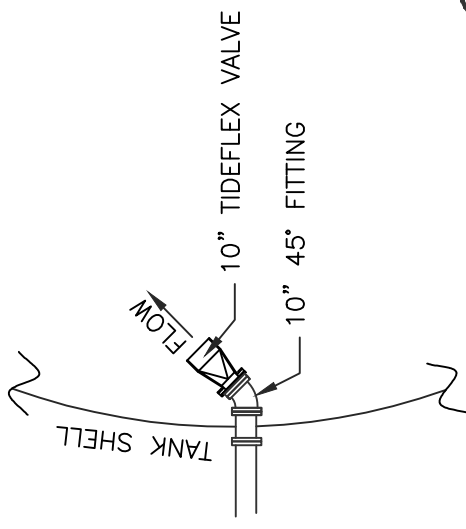

C/11

TANK INLET PIPING DETAIL

NOT TO SCALE

G/13

PIPE SUPPORT

CONNECT TO EXISTING TRANSITION TO PVC

H/14

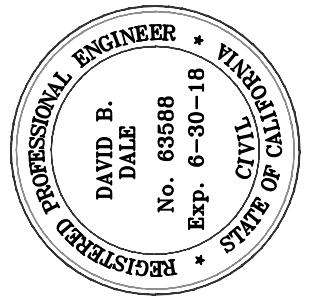

*David Dale*

3/11/2017

148	900 TANK REPLACEMENT		SHEET: 11
	TANK PIPING		OF: 17
CLIENT : BORREGO WATER DISTRICT		DATE: 12/15/16	BY: DB

ALL ABOVE GROUND PIPING TO BE COATED STEEL OR DUCTILE IRON (DI)

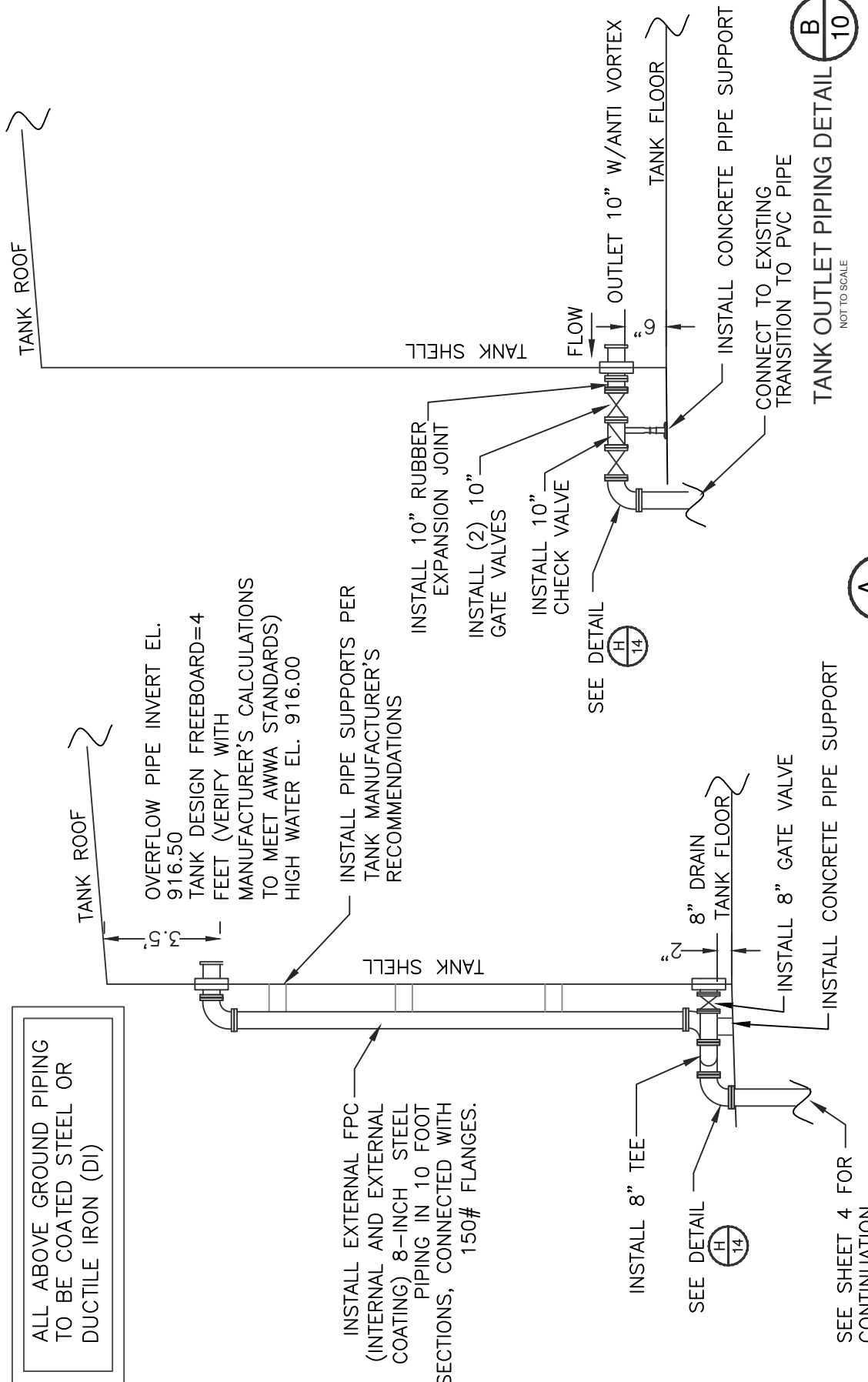

TANK OVERFLOW/DRAIN PIPING DETAIL  
NOT TO SCALE



TANK OUTLET PIPING DETAIL  
NOT TO SCALE

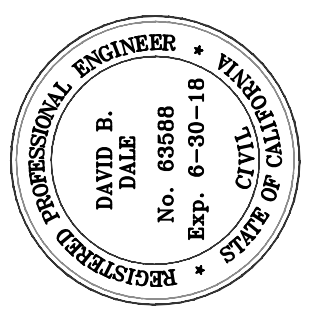

*David Dale*  
3/11/2017

900 TANK REPLACEMENT	SHEET: 10	BY: DB
	OF: 17	
TANK PIPING	DATE: 12/15/16	
CLIENT : BORREGO WATER DISTRICT		

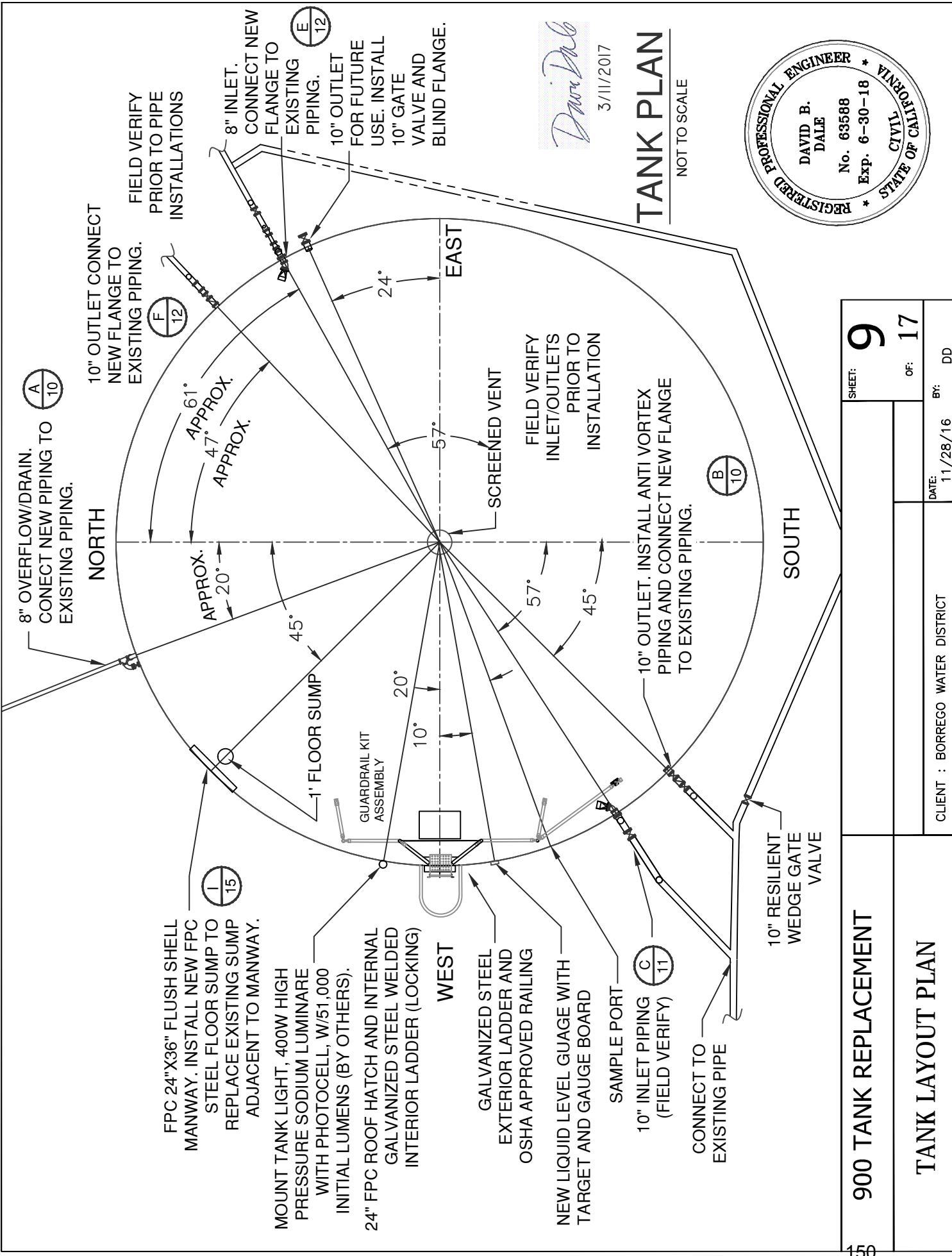

*David Dale*  
3/11/2017

**TANK PLAN**  
NOT TO SCALE

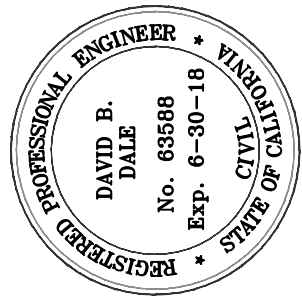

<b>900 TANK REPLACEMENT</b>	SHEET: <b>9</b>	OF: <b>17</b>
	DATE: 11/28/16 BY: DD	
CLIENT : BORREGO WATER DISTRICT		
<b>TANK LAYOUT PLAN</b>		



700,000 GALLON BOLTED WATER STORAGE TANK  
(NOMINAL - ACTUAL STORAGE 500,000 GALLONS)

FINAL EXACT DIMENSIONS OF TANK PER MANUFACTURER

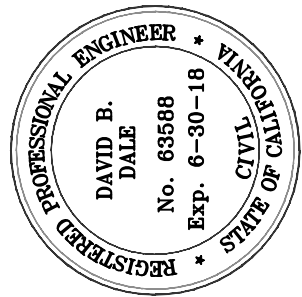
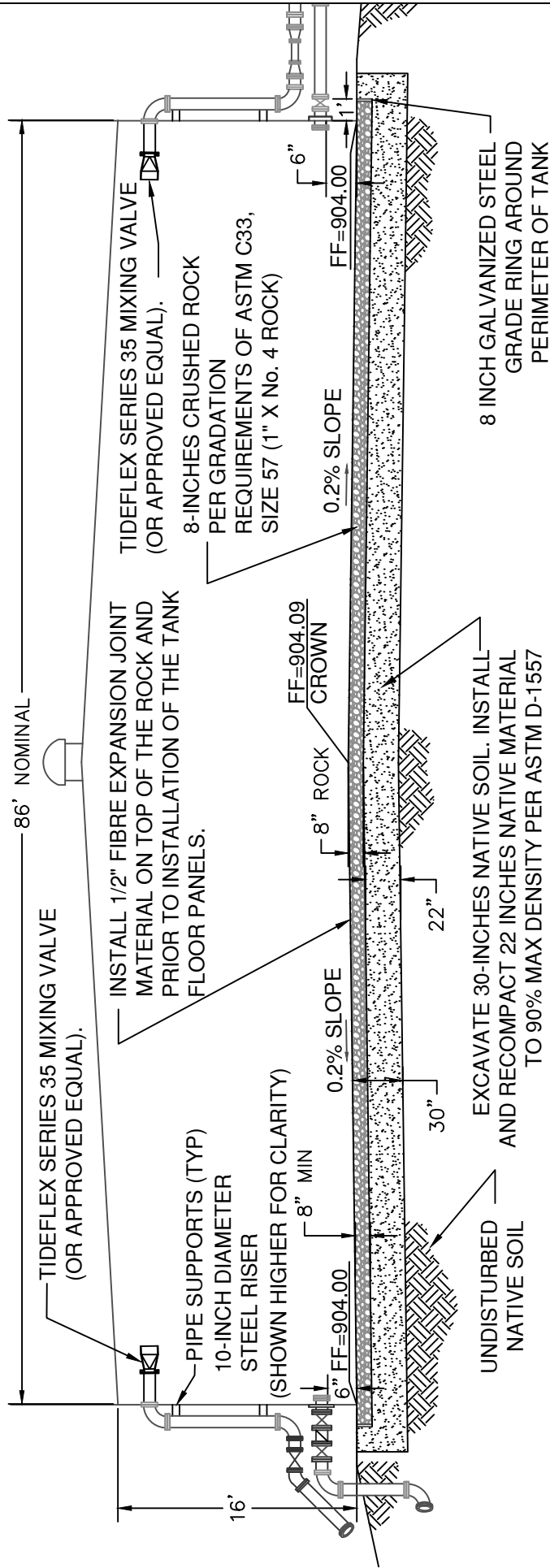

*David Dale*

3/11/2017

TANK DETAIL  
NOT TO SCALE

900 TANK REPLACEMENT	SHEET: <b>8</b>	BY: DB
	OF: <b>17</b>	
TANK FOUNDATION AND PROFILE	DATE: 12/1/16	
CLIENT : BORREGO WATER DISTRICT		

CONSTRUCT GALVANIZED LOCKING STEEL LADDER WITH BACKGUARD, ROOF PLATFORM, HANDRAIL AN FPC ROOF HATCH WITH LOCKING DEVICE PER OSHA REQUIREMENTS.

LADDER KIT PER MANUFACTURER

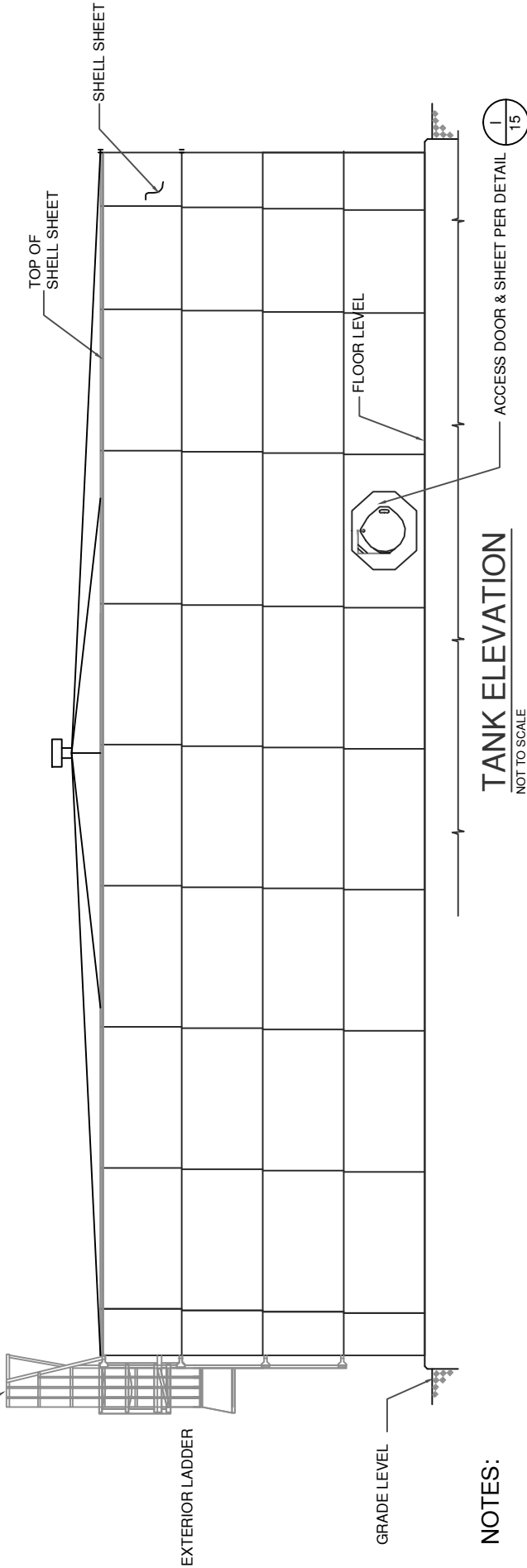

**NOTES:**

**TANK ELEVATION**  
NOT TO SCALE

1. THIS DRAWING IS NOT TO SCALE.
2. CONTRACTOR SHALL SUBMIT DETAILED DESIGN, STRUCTURAL AND SEISMIC CALCULATIONS FOR TANK.
3. **IMPORTANT -- FIELD ERECTION OF FACTORY POWDER COATED BOLTED STEEL TANKS SHALL BE IN STRICT COMPLIANCE WITH MANUFACTURER'S RECOMMENDATIONS AND PERFORMED BY MANUFACTURER'S EMPLOYEES OR CERTIFIED ERECTION CREW TO ALLEVIATE ANY POTENTIAL DISPUTES IN COATING QUALITY OR ERECTION THEREOF. PARTICULAR CARE SHALL BE EXERCISED IN HANDLING AND BOLTING OF THE TANK PLATES, SUPPORTS, AND MEMBERS TO AVOID ABRASION OR SCRATCHING THE COATING. PRIOR TO PLACING WATER IN THE TANK, A "HOLIDAY" INSPECTION OF THE ENTIRE TANK, CORNERS INCLUDED, WILL BE PROVIDED AND PERFORMED BY THE MANUFACTURER IN THE PRESENCE OF THE OWNER. TOUCH-UP COATING SHALL BE DONE PER THE MANUFACTURER'S RECOMMENDATIONS WHERE NEEDED AND AS DIRECTED TO ACHIEVE 100% HOLIDAY-FREE SURFACE. FINAL ACCEPTANCE OF THE PROJECT WILL NOT OCCUR UNTIL THE TANK IS COMPLETELY "HOLIDAY" FREE.**

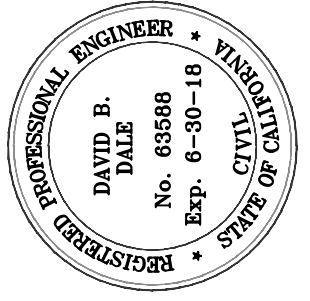

*David Dale*

3/11/2017

900 TANK REPLACEMENT	SHEET: <b>7</b>	DATE: 12/20/16	BY: DD
	BORRERO WATER DISTRICT		
TANK ELEVATION	OF: <b>17</b>		

LEGEND

- DEMOLISH
- - - TO REMAIN
- \_\_\_ NEW

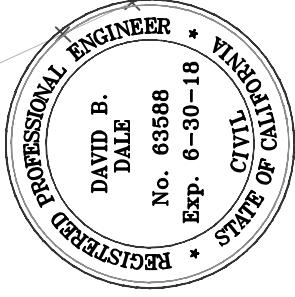
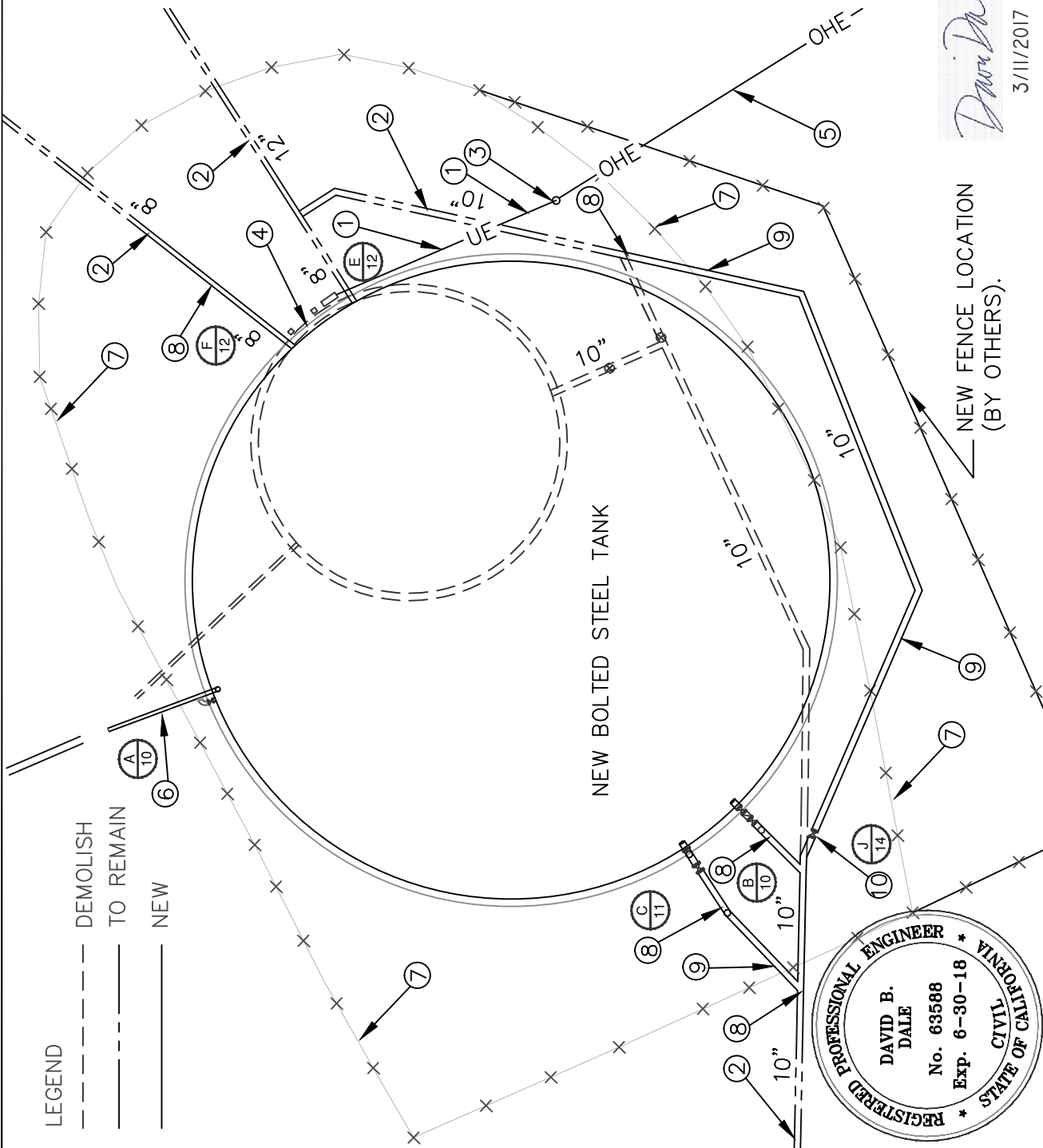

*David Dale*

3/11/2017

900 TANK REPLACEMENT

BORRERO WATER DISTRICT	SHEET: <b>6</b>
	OF: <b>17</b>
DATE: 12/20/16	BY: DD

PIPING PLAN

CONSTRUCTION KEYNOTES

- ① CAUTION - EXISTING BURIED ELECTRICAL
- ② EXISTING BURIED 8, 10 OR 12-INCH AC PIPE TO REMAIN AS SHOWN.
- ③ EXISTING POWER POLE TO REMAIN
- ④ ELECTRIC/TELEMETRY TO REMAIN. ALL WORK CONNECTING ELECTRIC AND TELEMETRY BY OTHERS.
- ⑤ CAUTION - EXISTING OVERHEAD ELECTRICAL
- ⑥ INSTALL 15 FEET NEW 8" DRAIN/OVERFLOW PIPE W/SS SCREEN AT END OF PIPE.
- ⑦ EXISTING FENCE AND GATE TO BE REMOVED AND REPLACED (BY OTHERS).
- ⑧ CONNECT TO EXISTING ASBESTOS CONCRETE (AC) PIPING VIA TRANSITION COUPLING. VERIFY PIPE SIZE IN FIELD.
- ⑨ INSTALL NEW PIPING PER DETAIL 
- ⑩ INSTALL NEW 10" BURIED RESILIENT WEDGE GATE VALVE PER DETAIL SHOWN.



SCALE: 1" = 20'  
ON 8.5" x 11"  
PAPER

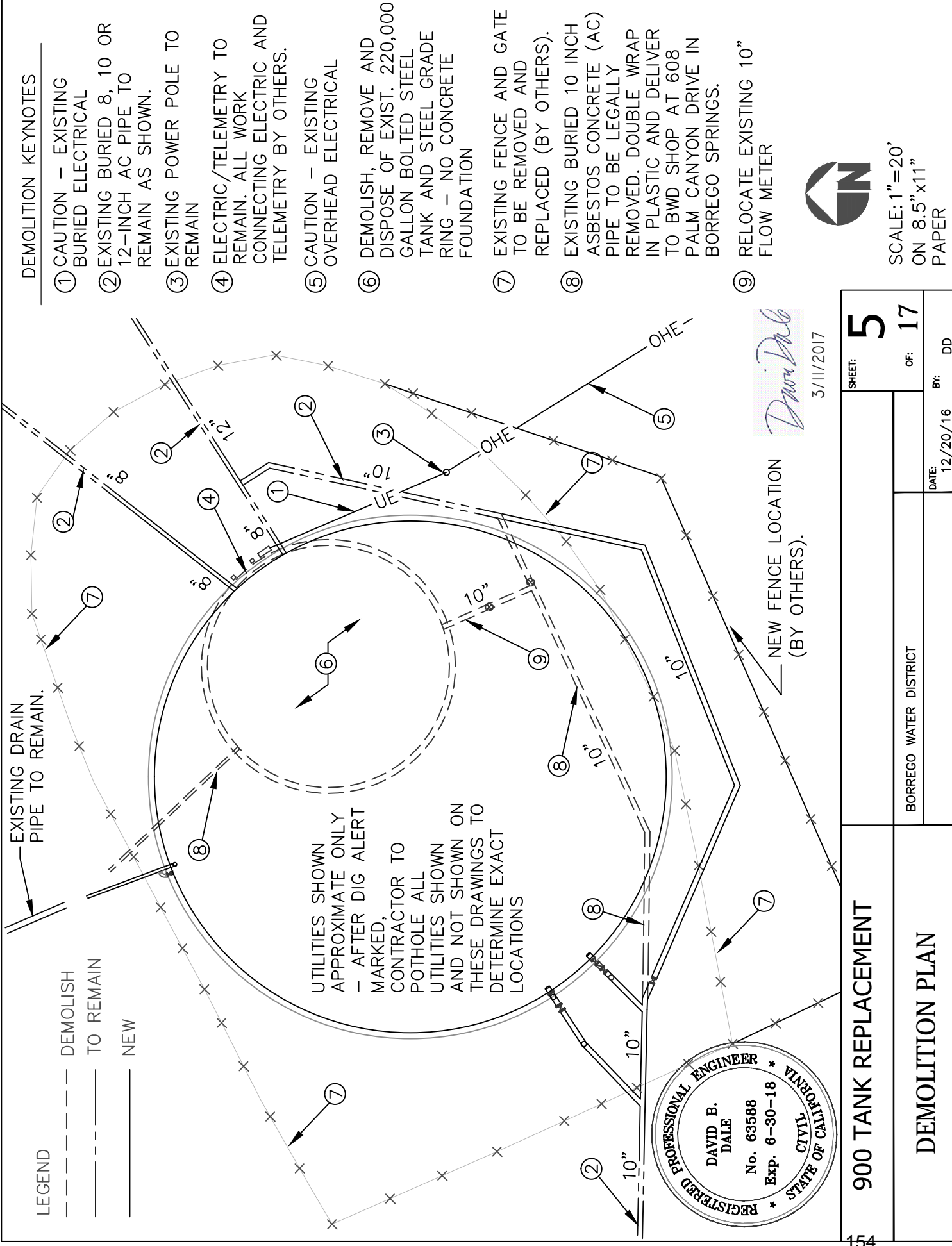

**DEMOLITION KEYNOTES**

- ① CAUTION - EXISTING BURIED ELECTRICAL
- ② EXISTING BURIED 8, 10 OR 12-INCH AC PIPE TO REMAIN AS SHOWN.
- ③ EXISTING POWER POLE TO REMAIN
- ④ ELECTRIC/TELEMETRY TO REMAIN. ALL WORK CONNECTING ELECTRIC AND TELEMETRY BY OTHERS.
- ⑤ CAUTION - EXISTING OVERHEAD ELECTRICAL
- ⑥ DEMOLISH, REMOVE AND DISPOSE OF EXIST. 220,000 GALLON BOLTED STEEL TANK AND STEEL GRADE RING - NO CONCRETE FOUNDATION
- ⑦ EXISTING FENCE AND GATE TO BE REMOVED AND REPLACED (BY OTHERS).
- ⑧ EXISTING BURIED 10 INCH ASBESTOS CONCRETE (AC) PIPE TO BE LEGALLY REMOVED. DOUBLE WRAP IN PLASTIC AND DELIVER TO BWD SHOP AT 608 PALM CANYON DRIVE IN BORREGO SPRINGS.
- ⑨ RELOCATE EXISTING 10" FLOW METER

**LEGEND**

--- DEMOLISH TO REMAIN

\_\_\_ NEW

UTILITIES SHOWN APPROXIMATE ONLY - AFTER DIG ALERT MARKED, CONTRACTOR TO POTHOLE ALL UTILITIES SHOWN AND NOT SHOWN ON THESE DRAWINGS TO DETERMINE EXACT LOCATIONS

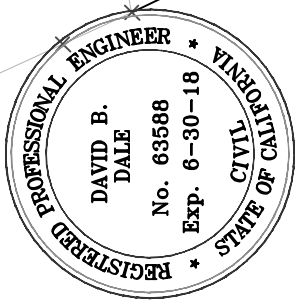

*David Dale*

3/11/2017



SCALE: 1" = 20'  
ON 8.5" x 11"  
PAPER

<b>900 TANK REPLACEMENT</b>	SHEET: <b>5</b>	
	OF: <b>17</b>	
<b>DEMOLITION PLAN</b>	BORREGO WATER DISTRICT	
	DATE: 12/20/16	BY: DD



SCALE: 1" = 30'  
ON 8.5" x 11"  
PAPER

*David B. Dale*

3/11/2017

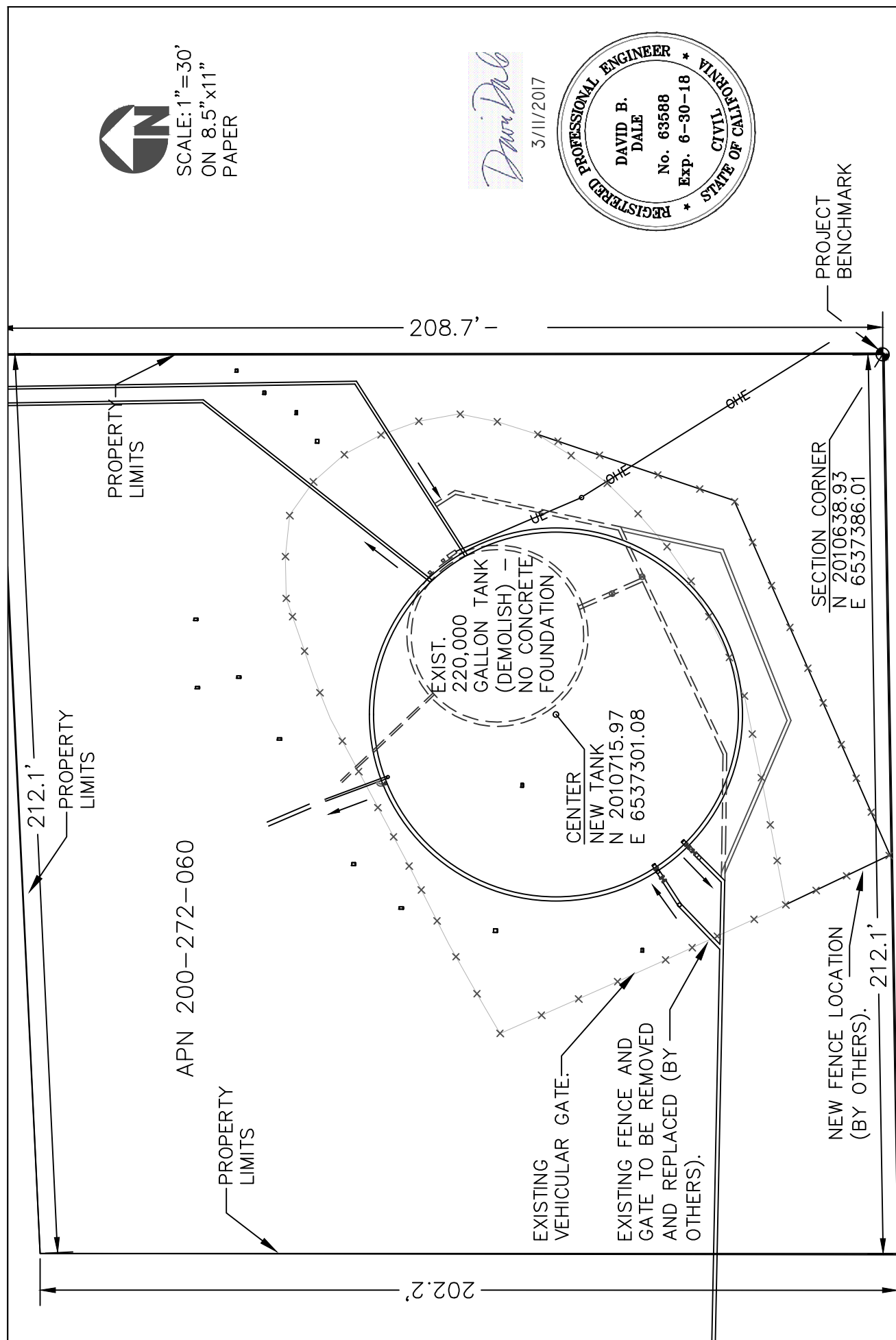
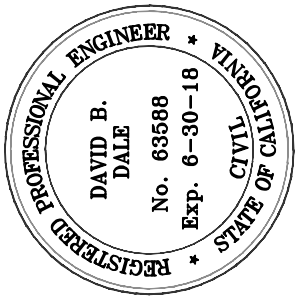

PROJECT BENCHMARK SE CORNER OF SECTION 27, T.11S R.6E, 2 INCH IRON PIPE 18 INCHES ABOVE GROUND WITH ORIGINAL TAG. ELEVATION = 905.84

155	900 TANK REPLACEMENT		SHEET: <b>4</b>
	SITE PLAN		OF: <b>17</b>
BORRERO WATER DISTRICT		DATE: 12/20/16	BY: DD

BORREGO WATER DISTRICT GENERAL NOTES (CONTINUED)

- 11. PIPE: AWWA C-900 AND C-905. PIPE SHALL BE 235 PSI, DR18. ALL PIPES SHALL HAVE BELL AND SPIGOT, ELASTOMERIC GASKETED JOINTS. PIPE SHALL BE SUPPLIED WITH AN AFFIDAVIT OF COMPLIANCE.
- 12. FITTINGS: AWWA C-153 AND C-104. FITTINGS SHALL BE CEMENT-MORTAR LINED. UNLESS OTHERWISE SHOWN OR INDICATED BY THE CONTRACT DRAWINGS, BENDS SHALL BE FURNISHED WITH MECHANICAL JOINT ENDS; TEES AND CROSSES SHALL BE FURNISHED WITH FLANGED JOINT ENDS. FLANGE TO MECHANICAL JOINT ADAPTERS SHALL BE FURNISHED TO CONNECT PIPE TO TEES AND CROSSES WHERE VALVES DO NOT OCCUR. GLANDS SHALL BE OF THE SAME MANUFACTURER AS FITTINGS.
- 13. PIPELINE CONSTRUCTION – ALL WATER PIPE, FITTINGS AND APPURTENANCES CALLED FOR SHALL BE INSTALLED AND TESTED IN ACCORDANCE WITH THE FOLLOWING REFERENCED STANDARDS, THOSE OTHER STANDARDS THEREIN REFERENCED, THE WRITTEN RECOMMENDATIONS OF THE MANUFACTURER AND THESE SPECIAL PROVISIONS.
  - A. INSTALLATION: AWWA C-600 AND C-605. EXCESS EARTH FROM EXCAVATION SHALL BE REMOVED FROM THE ROADWAY SECTION AND DISPOSED OF. A TRACING WIRE AND APPROPRIATE UTILITY WARNING IDENTIFICATION TAPE SHALL BE PLACED IMMEDIATELY ABOVE THE PIPE ZONE BACKFILL. THE TEST PRESSURE FOR THE PIPE STRENGTH AND LEAKAGE SHALL BE NO LESS THAN 150 PSI. IN ALL EASEMENTS, FLEXIBLE HIGH VISIBILITY IDENTIFICATION MARKERS ARE ADDITIONALLY REQUIRED.

**NOTES TO CONTRACTOR**

THE EXISTENCE AND LOCATION OF ANY UNDERGROUND UTILITY PIPES, CONDUITS OR STRUCTURES SHOWN ON THESE PLANS ARE OBTAINED BY A SEARCH OF THE AVAILABLE RECORDS. TO THE BEST OF OUR KNOWLEDGE THERE ARE NO EXISTING UTILITIES EXCEPT AS SHOWN ON THESE PLANS. THE CONTRACTOR IS REQUIRED TO TAKE DUE PRECAUTIONARY MEASURES TO PROTECT THE UTILITY LINES SHOWN ON THESE DRAWINGS. THE CONTRACTOR FURTHER ASSUMES ALL LIABILITY AND RESPONSIBILITY FOR THE UTILITY PIPES, CONDUITS OR STRUCTURES SHOWN OR NOT SHOWN ON THESE DRAWINGS.

CONSTRUCTION CONTRACTOR AGREES THAT IN ACCORDANCE WITH GENERALLY ACCEPTED CONSTRUCTION PRACTICES, CONSTRUCTION CONTRACTOR WILL BE REQUIRED TO ASSUME SOLE AND COMPLETE RESPONSIBILITY FOR JOB SITE DURING THE COURSE OF CONSTRUCTION OF THE PROJECT, INCLUDING SAFETY OF ALL PERSONS AND PROPERTY. THIS REQUIREMENT SHALL BE MADE TO APPLY CONTINUOUSLY AND NOT BE LIMITED TO NORMAL WORKING HOURS, AND CONSTRUCTION CONTRACTOR FURTHER AGREES TO DEFEND, INDEMNIFY AND HOLD DESIGN PROFESSIONAL HARMLESS FROM ANY AND ALL LIABILITY, REAL OR ALLEGED, IN CONNECTION WITH THE PERFORMANCE OF WORK ON THIS PROJECT, EXCEPTING LIABILITY ARISING FROM THE SOLE NEGLIGENCE OF DESIGN PROFESSIONAL.

CONTRACTOR TO POSSES A VALID CLASS A CONTRACTOR'S LICENSE IN THE STATE OF CALIFORNIA FOR ALL WORK SHOWN IN THESE PLANS.

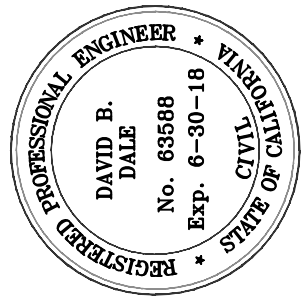

*David Dale*

3/11/2017

900 TANK REPLACEMENT	SHEET: <b>3</b>	DATE: 12/20/16	BY: DD
	BORREGO WATER DISTRICT		
GENERAL NOTES	OF: <b>17</b>		



BORREGO WATER DISTRICT GENERAL NOTES (TYPICAL)

1. WATER WORKS SHALL BE CONSTRUCTED IN ACCORDANCE WITH THE DETAILS AND MATERIALS AS SPECIFIED IN THE MOST CURRENT EDITION OF THE STANDARDS OF THE AMERICAN WATER WORKS ASSOCIATION. CONTRACTOR SHALL HAVE A CURRENT COPY OF THE STANDARD SPECIFICATIONS ON THE JOB SITE AT ALL TIMES.
2. THE SUBMISSION AND REVIEW OF ALL SUBMITTALS AS REQUIRED BY THE STANDARD SPECIFICATIONS ARE TO BE ACCOMPLISHED PRIOR TO THE PRECONSTRUCTION MEETING WITH THE COUNTY INSPECTOR.
3. NO WORK MAY BEGIN OR PROCEED WITHOUT DIRECTION OF THE COUNTY INSPECTOR. INSPECTOR'S SCHEDULING MUST BE 24-48 HOURS IN ADVANCE OF WORK.
4. WHERE ELEVATIONS AND GRADES ARE NOT SHOWN ON THE WATER MAIN PROFILE, TOP OF PIPE PROFILE IS 36-INCHES MINIMUM BELOW CENTERLINE OF FINISH GRADE OF STREET.
5. CONTRACTOR SHALL REVIEW ALL PROPOSED TRENCH WORK WITH CAL/OSHA. A COPY OF EXEMPTION LETTER OR TRENCHING PERMIT, IF REQUIRED SHALL BE SUBMITTED TO THE COUNTY PRIOR TO CONSTRUCTION.
6. ALL EXISTING FACILITIES, WHICH MAY AFFECT FINAL DESIGN, I.E., LINE CROSSINGS, LINE PARALLELING, OR PROPOSED CONNECTIONS SHALL BE FIELD VERIFIED. ALL EXISTING OR PROPOSED UTILITY CROSSINGS, OR UTILITIES WITHIN 10- FEET OF PROPOSED WATER MAINS, SHALL BE SHOWN ON IMPROVEMENT PLANS.
7. THE WATER SYSTEM SHALL BE PRESSURE TESTED IN ACCORDANCE WITH THE PROCEDURES IN THE STANDARD SPECIFICATIONS. THE CLASS OF PIPE SHALL BE USED AS THE DESIGNATED WORKING PRESSURE FOR TESTING ALL PIPES, VALVES (CLOSED) AND APPURTENANCES.
8. ALL DEFLECTIONS (HORIZONTAL AND VERTICAL) SHALL BE MADE BY USE OF JOINT COUPLINGS WITH 4-INCH MAXIMUM DEFLECTION PER COUPLING (2-INCH PER JOINT). NO BENDING (CURVING) OF PIPE SHALL BE PERMITTED.
9. STANDARDS - STANDARD TO BE USED SHALL MEAN THOSE STANDARDS OF THE AMERICAN WATER WORKS ASSOCIATION LATEST REVISION. SAID STANDARDS ARE AVAILABLE FROM THE BOOKSTORE OF SAID ASSOCIATION, 6666 W. QUINCY AVE. DENVER, CO. 80235, (800) 926-7337.
10. MATERIALS OF CONSTRUCTION - ALL WATER PIPE, FITTINGS AND APPURTENANCES CALLED FOR IN THESE CONTRACT DOCUMENTS SHALL CONFORM TO THE FOLLOWING STANDARDS, THOSE OTHER STANDARDS THEREIN REFERENCED AND THESE SPECIAL PROVISIONS.

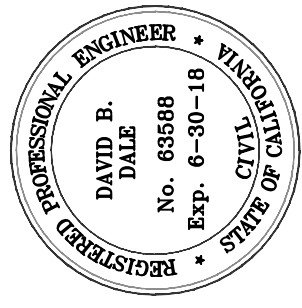

*David Dale*  
3/11/2017

900 TANK REPLACEMENT	SHEET: <b>2</b>	DATE: 12/20/16	BY: DD
	BORREGO WATER DISTRICT		OF: 17
GENERAL NOTES			

# VICINITY MAP

PROJECT SITE IS LOCATED APPROXIMATELY 4,000 FEET SOUTH OF RAMS HILL ROAD ALONG YAQUI PASS ROAD (S3)

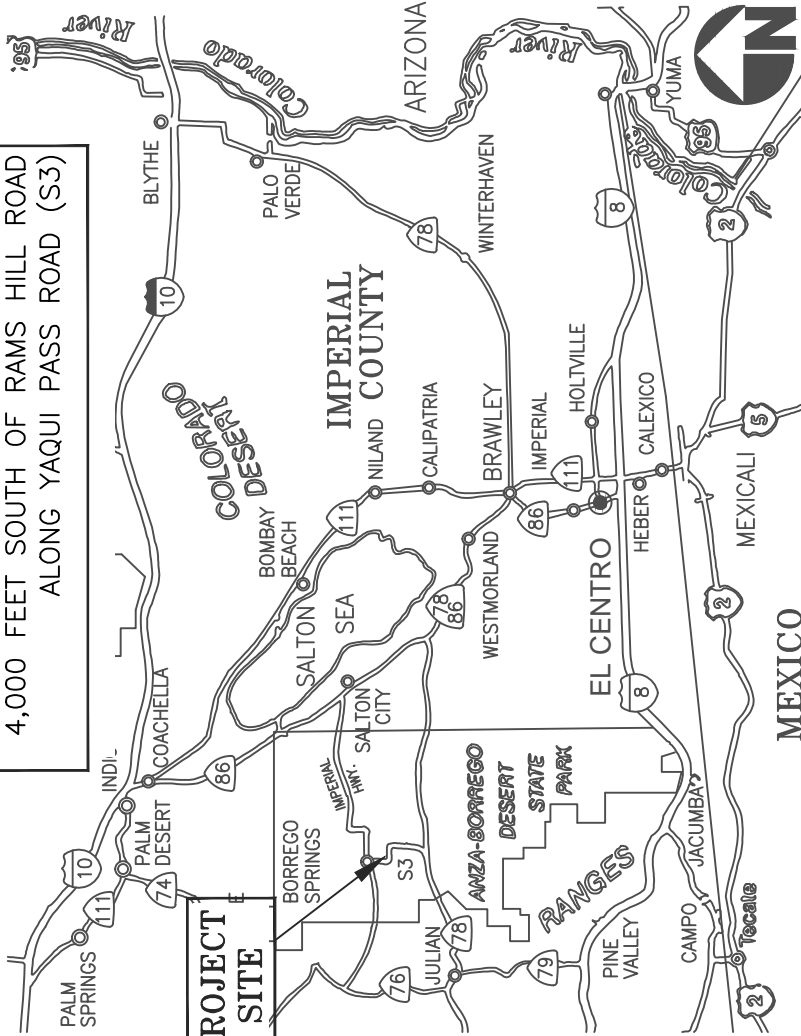

PROJECT CONSISTS OF DEMOLISHING EXISTING 220,000 GALLON BOLTED STEEL GROUND STORAGE RESERVOIR, THE TANK IS TO BE REPLACED WITH A LARGER CAPACITY TANK. THE EXISTING TANK IS CURRENTLY EMPTY. THE CONTRACTOR SHALL REMOVE AND DISPOSE OF THE EXISTING BOLTED STEEL TANK, PERPARE A NEW TANK PAD AND INSTALL A NEW 700,000 GALLON BOLTED STEEL TANK PER THE DETAILS ON THE FOLLOWING SHEETS. STAGING AREA IS WITHIN BWD OWNED PROPERTY.

## SHEET INDEX

1. TITLE SHEET
2. GENERAL NOTES
3. GENERAL NOTES
4. SITE PLAN
5. DEMOLITION PLAN
6. PIPING PLAN
7. TANK ELEVATION
8. TANK FOUNDATION AND PROFILE
9. TANK LAYOUT PLAN
10. TANK PIPING
11. TANK PIPING
12. TANK PIPING
13. TANK PIPING
14. TANK PIPING
15. MANWAY DETAIL
16. LIQUID LEVEL DETAILS
17. LIQUID LEVEL DETAILS

*David Dale*

3/11/2017

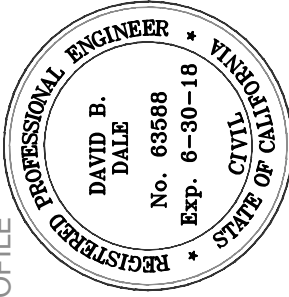

## AGENCY CONTACTS

BORREGO WATER DISTRICT  
 GEOFF POOLE, GENERAL MANAGER  
 806 PALM CANYON DRIVE BORREGO SPRINGS, CA 92004

TEL. (760) 767-5806

EMAIL: [Geoff@borregowd.org](mailto:Geoff@borregowd.org)

STATE WATER RESOURCES CONTROL BOARD DIVISION  
 OF DRINKING WATER FIELD OPERATIONS BRANCH  
 SAN DIEGO DISTRICT

BILL DIBIASE  
 1350 FRONT STREET, SUITE 2050  
 SAN DIEGO, CA 92101  
 PHONE: (619) 525-4383 EMAIL: [William.Dibiase@waterboards.ca.gov](mailto:William.Dibiase@waterboards.ca.gov)

58	900 TANK REPLACEMENT	SHEET: <b>1</b>	SDG&E
	TITLE SHEET	OF: <b>17</b>	PHONE: 800-655-4555
	BORREGO WATER DISTRICT	DATE: 12/20/16	BY: DD



## 1-56 CLAIMS

The following is a summary of Public Contract Code section 9204 and shall be the procedures that the DISTRICT and the Contractor shall follow for the handling of claims (as defined in section 9204 and below):

a) Notwithstanding the foregoing, and notwithstanding any other law, including Public Contract Code section 20104, any separate demand by the Contractor, sent to the DISTRICT by registered mail or certified mail with return receipt requested, for any one or more of the following:

1) A time extension, including, but not limited to, for relief from damages or penalties for delay assessed by the DISTRICT under this Contract; or

2) Payment by the DISTRICT of money or damages arising from work done by, or on behalf of, the Contractor (or, as provided in subsection (j), below, by the Contractor on behalf of a subcontractor or a lower tier subcontractor) pursuant to this Contract, and where payment for which is not otherwise expressly provided herein or to which the Contractor is not otherwise entitled ("Claim");

shall be processed as set forth in this section 1-56.

b) Upon the receipt of a Claim the DISTRICT shall conduct a reasonable review of the Claim and within a period not to exceed 45 days, shall provide the Contractor with a written statement identifying what portion of the Claim is disputed and what portion of the Claim is undisputed. Upon the receipt of a Claim the DISTRICT, through the General Manager, and the Contractor may, by mutual agreement, extend the time period provide in this subsection (b).

c) As a condition precedent to the Claim the Contractor must include reasonable documentation to support its Claim.

d) The DISTRICT's response to the Claim must be approved by its Board of Directors. If the Board of Directors will not meet within the initial 45 days or any extension mutually agreed upon between the DISTRICT's General Manager and the Contractor as permitted by subsection (b), above, the DISTRICT shall have up to three (3) days following the next duly publicly noticed meeting of the Board of Directors after the 45-day period, or extension, expires to provide the Contractor with a written statement identifying the disputed portion and the undisputed portion.

e) Payment due on any undisputed portion of the Claim shall be processed and made within 60 days following the issuance of the written statement required in subsection (d). If the DISTRICT fails to issue a written statement the provisions of subsection (h), below, shall apply.

f) If the Contractor disputes the DISTRICT's written response, or if the DISTRICT fails to respond to the Claim within the time prescribed by this Section 1-56, the Contractor may demand in writing an informal conference to meet and confer for settlement of the issues in dispute. Upon receipt of a written demand for meet and confer, sent by registered mail or certified mail, return receipt requested, the DISTRICT shall schedule a meet and confer conference in Borrego Springs, California, to be held within 30 days.

g) Within 10 business days following the conclusion of the meet and confer conference, if the Claim or any portion thereof remains in dispute, the DISTRICT shall provide the Contractor with a written statement identifying the portion of the Claim that remains in dispute and the portion of the Claim that is undisputed.

1) Any payment due on an undisputed portion of the Claim following the meet and confer conference shall be processed and made within 60 days after the DISTRICT has issued its written statement required by this subsection (g).

2) Any disputed portion of the Claim, as identified by the Contractor in writing, shall be submitted to nonbinding mediation in San Diego County, with the DISTRICT and the Contractor sharing the costs of mediation (i.e., the costs charged by the mediator) equally. The DISTRICT and the Contractor shall mutually agree to a mediator within 10 business days after the disputed portion of the Claim has been identified by the DISTRICT as required by this subsection (g). If the DISTRICT and the Contractor fail to agree upon a mediator, each party shall select a mediator, and those mediators shall select a qualified neutral third party to mediate the disputed portion of the Claim.

i) In the event the mediation is conducted by a qualified neutral third party mediator, selected by the parties' mediators, each party shall bear the fees and costs charged by its selected mediator in connection with the selection of the neutral mediator. The costs of the neutral mediator shall be shared equally as set forth in subdivision (g)(2) of this Section 1-56.

ii) For the purposes of this Section 1-56, mediation includes any nonbinding process, including, but not limited to, neutral evaluation or a dispute review board (if applicable), in which an independent third party or board assist the DISTRICT and the Contractor in dispute resolution through negotiation or the issuance of an evaluation of the Claim. Any mediation utilized shall conform to the timeframes set forth in this Section 1-56.

iii) If mediation is unsuccessful, the portions of the Claim remaining in dispute shall be subject to such other procedures outside of this Section, applicable to the Claim.

iv) Unless the DISTRICT and the Contractor otherwise agree in writing, the mediation conducted pursuant to this subsection (g) shall excuse any further

obligation under California Public Contract Code section 20104.4 to mediate after litigation is commenced.

h) Should the DISTRICT fail to respond to a Claim within the time periods set forth herein or otherwise meet the time requirements of this Section 1-56, the Claim shall be deemed rejected in its entirety. A Claim that is deemed denied pursuant to this subsection (h) shall not constitute an adverse finding with regard to the merits of the Claim or the responsibility or qualifications of the Contractor.

i) Any amounts not paid in a timely manner as required by this Section 1-56 shall bear interest at the rate of seven percent (7%) per annum.

j) Claims of any subcontractor or a lower tier subcontractor, against the DISTRICT, which cannot be brought directly against the DISTRICT due to lack of privity of contract, may be presented to the DISTRICT by the Contractor on behalf of that claimant. A Subcontractor, on his or her own behalf, or on behalf of a lower tier subcontractor must request that the Contractor present the Claim on behalf of the subcontractor. In requesting that the Contractor present his or her Claim the subcontractor must furnish the Contractor with reasonable documentation to support the Claim. Within 45 days of receipt of this written request the Contractor must notify the subcontractor, in writing, as to whether the Claim was presented to the DISTRICT and, if not presented, a statement of the reasons why it was not presented.

k) If a Claim is not resolved through negotiation or mediation a Contractor or any subcontractor having presented the Claim through this procedure may thereafter seek such remedies. Any action must be brought in the Superior Court in San Diego County, and the claimant shall be deemed to have waived the provisions of California Code of Civil Procedure section 394, which otherwise allows the removal of such an action.

BORREGO WATER DISTRICT  
BOARD OF DIRECTORS MEETING – MARCH 14, 2017  
AGENDA BILL II.C

March 8, 2017

TO: Board of Directors, Borrego Water District  
FROM: Geoff Poole, General Manager  
SUBJECT: Clarification of Policy for Water and Sewer Service to New Developments – G. Poole

**RECOMMENDED ACTION:** Approve staff recommendations to clarify New Development Policy

**ITEM DESCRIPTION:** Recently, Greg has been receiving an increase in requests, not necessarily installations, for new water meter cost estimates. The increase in requests for new meters prompted Staff to look at the existing policies and procedures.

One policy that Staff would like to clarify is the current practice that allows for property owner to have a water meter installed prior to development without paying the necessary Water Credits. The current New Development Policy does include sections where it says Water Credits must be paid, but that theme is not consistent throughout the entire document, and those have been corrected. A few other updates were made to the Policy mostly pertaining to outdated rates and charges. The changes are highlighted in the Attachments.

**FISCAL IMPACT:** N/A

**ATTACHMENTS:** Proposed New Development Policy

# BORREGO WATER DISTRICT

## POLICY STATEMENT

SUBJECT: Policy on New Development

NO. 2005-6-1

ADOPTED: June 22, 2005  
AMENDED: December 27, 2006  
AMENDED: February 20, 2013  
AMENDED: March 23, 2016  
AMENDED: March 22, 2017

**Background:** There are always discussions about responsibility for costs when a developer seeks to add an area of water and sewer service to a new development. As a general rule, the Borrego Water District (BWD) requires the development to pay its own way, desiring not to subsidize growth. This is only fair to existing customers. Sometimes, however, BWD desires to extend a water or sewer line at its own cost whenever the result will be an improvement to the system. Because these are differing directions, the differences can sometimes become blurred. BWD has attempted to resolve the issues with its developer policy. This policy will need to be reviewed from time to time to determine its applicability. What is needed for effective strategic planning is a statement of policy on the subject affirming the general direction.

**Policy:** It is the policy of the Borrego Water District (BWD) to encourage responsible growth by requiring new developers to install water and sewer connector lines at the developer's expense, in addition to the assessment of developer charges for each new connection to pay for any improvements required to the existing BWD system and the use of existing system capacity. Participation in costs by BWD will occur only when BWD is convinced such connector lines will add further benefit to the District.

## **POLICY FOR WATER AND SEWER SERVICE TO NEW DEVELOPMENTS**

**March 22, 2017**

This Policy outlines the procedures and obligations for developers, contractors, and owners (hereinafter “developers”) to obtain water and sewer service from the Borrego Water District (hereinafter “District”) to serve a new development and establishes the fees, exactions, and charges for the new development. The Policy also applies to new construction of residential homes on existing platted lots within the District. The term "new development" is defined as any residential or commercial development or service requirement that increases the demand on the District's water supply and/or distribution system and/or its sewer collection and treatment system whether by increasing the intensity of use or by altering the use of land.

### **1. Application of Policy**

This Policy governs the procedures for the District to handle requests for a commitment for water and sewer service for new developments and sets forth the obligations of the developer to obtain a commitment for water and sewer service. When a developer requests a commitment for water and sewer service for a larger new development, for example, a “major subdivision,” as defined in the San Diego County Code of Regulatory Ordinances at section 81.102(y) as “a subdivision creating five or more lots or units” that may substantially impact the District’s existing water supply capacity and/or sewer treatment capacity or that may require major improvements to the District’s water distribution system and/or to the District’s sewer treatment plant or collection system, such requests shall be considered on a case-by-case basis. This Policy shall serve as a guideline for the consideration of the request for water and sewer service for a larger new development, but the District may modify or add to the provisions of this Policy in making its commitment for water and sewer service for a larger development.

### **2. Application for Water and Sewer Service**

(a) The developer must obtain an Application for Water and Sewer Service from the District. With the Application the developer shall submit a preliminary plat of the development which shall include the number of lots to be served, the type of units to be built within the development, the size of the lots in the development, the estimated build-out of the new development and any other information that will assist the District in determining the water and sewer needs of the new development.

(b) The developer must return the completed Application to the District with the information requested in subsection (a). The developer shall provide any other information requested by the District that the District deems necessary to determine the availability of water and sewer service for the development.

(c) When the Application requests water and sewer service for a larger new development, the developer shall pay an Application Fee as set by the District’s Manager at the time the Application is submitted. The Application Fee shall cover the anticipated cost to the

District of reviewing the project, obtaining any engineering report on the feasibility of the water and sewer service requested for the project and making a preliminary determination of the on-site and off-site system improvements necessary to provide the water and sewer service requested. The Application Fee is non-refundable. The Application Fee shall be credited against the Administrative Fee set forth in Section 6(a) of this Policy.

(d) The developer must timely notify the District of any changes in the information submitted with the Application.

(e) When the Application is complete and the Application Fee, if applicable, is paid, the District will determine, with the assistance of the District's engineer if necessary, whether the water and sewer service requested is available and whether any off-site water and sewer system improvements must be made to the District's water and sewer system to properly serve the new development and maintain the current level of water and sewer service to the District's existing customers.

(f) When the District has completed its review, the developer will be notified of the preliminary conclusions of the District as to the feasibility of the water and sewer service requested. The District may then issue a Water and Sewer Availability Letter to the developer. The Water and Sewer Availability Letter may be revoked unless the developer enters into a contract with the District and pays all fees assessed by the District within three hundred sixty (360) days of the date of the Water and Sewer Availability Letter.

### 3. Conditions on Availability of Water and Sewer Service

(a) In determining whether water and sewer service is available, the District may require that the developer provide an accurate projection of the water demand and sewer treatment needs, by a registered engineer, for the entire development upon the Application for the first section or phase of the development.

(b) The District may issue its Water and Sewer Availability Letter with limitations on the maximum amount of water that can be provided to the new development and the maximum amount of wastewater that can be collected and treated for the development. Any maximum limits on water and sewer service for the development shall be included in the water service contract with the developer under Section 4.

### 4. Water and Sewer Service Contract

(a) Before water and sewer system improvements are installed for the new development, the District, with the assistance of the District's attorney if necessary, will then prepare a contract under which water and sewer service will be provided to the development.

(b) The District may incorporate in the water and sewer service contract the maximum amount of water that can be furnished and the maximum amount of wastewater that can be collected and treated by the District. In the event the developer's demand for water and

sewer service exceeds the developer's projection of demand during the build out of the development, the District shall have no obligation to furnish water or provide wastewater collection and treatment in excess of the amounts set forth in the water and sewer service contract. Any request for water and sewer service in excess of the amounts projected by the developer and included in the Water and Sewer Service Contract shall be treated as a new request for water and sewer service under this Policy.

(c) A Water and Sewer Service Contract cannot be assigned to any successor in interest of the developer without the express written consent of the District.

## 5. Installation of Improvements

(a) **Cost of Installation.** At its own expense and at no cost and expense to the District, the Developer shall furnish, install, lay and construct all on-site and off-site water and sewer system improvements, including all labor and material, as required by the District to be installed to serve the development, to maintain the current level of water and sewer service to existing customers and to meet the District's plan for the level of service to be made available in the general area of the development. The construction and installation of the water and sewer system improvements shall be in strict accordance with the plans, specifications and requirements approved by the District. In addition, the developer shall indemnify the District from any loss or damage that may directly or indirectly result from the installation of water and sewer system improvements by the developer.

(b) **Notification of Construction.** The District shall be notified at least forty-eight (48) hours before construction is to begin on installation of improvements. Thereafter, the developer shall notify the District of every day during which construction will be in progress in order for the District's inspector to be on the job site during construction.

(c) **Inspections.** All water and sewer system improvement projects shall be subject to inspection during construction and upon completion of the construction by an authorized representative of the District. Inspection may consist of full-time resident inspection or part-time inspection at the sole discretion of the District. The presence or absence of an inspector during construction does not relieve the developer from adherence to approved plans and specifications. Materials and workmanship found not meeting the requirements of approved plans and specifications shall be immediately brought into conformity with said plans and specifications at the developer's expense.

(d) **Final Inspection.** An authorized representative of the District shall make a final inspection of the water and sewer system improvements for the development after completion to determine acceptability of the work. Before this final inspection can be made, the owner, developer or engineer responsible for the project shall notify the District's Manager in writing that the work has been completed in accordance with approved plans and specifications.

(e) **Final Acceptance.** When the water and sewer system improvements pass the District's final inspection, the District will accept ownership of the completed improvements.



The developer shall be responsible for seeing that the person paying the cost of constructing such improvements shall furnish "as-built" drawings to the District at the end of each phase of water and sewer system construction and prior to final acceptance of water and sewer system improvements by the District. The date of final acceptance shall be that date on which the developer has fulfilled all conditions necessary for final acceptance, including passing a final inspection, submitting "as-built" drawings, payment of all fees due, and the placing of all water and sewer system improvements into service by the District. The District will notify the developer in writing of the date of its acceptance of the completed facilities.

(f) "As-Built" Plans. The developer shall provide the District "as-built" plans, by a registered engineer, which shall be drawn at a scale of one inch equals 50 feet and which shall indicate the location and size of all water and sewer system improvements installed for the development. The location of all water and sewer system improvements must be referenced off of two (2) permanent points such as power poles, right-of-way markers, concrete monuments, iron pins at property corners, drainage culverts, and building corners. The water and sewer system improvements shall also be shown in relationship to the edge of all paved surfaces and all other utilities located with 15 feet of either side of the improvements. All utility easements shall be shown in relationship to the improvements. In the event the actual construction differs from the recorded plat of the development, the developer will prepare and record in the Register's Office of San Diego County a revised plat showing the actual construction with the design features stated above clearly shown. The District may delay water and sewer service until this requirement has been met.

(g) Warranty. The developer shall guarantee all work on the water and sewer system improvements it installs for a period of one (1) year from the date of final acceptance and shall immediately correct any deficiencies in the work due to material or workmanship that occurs during the one-year period. The warranty shall be insured by a maintenance bond in the amount specified by the District secured by an irrevocable bank letter of credit or such similar collateral as approved by the District. When a defect is discovered in any water or sewer system improvement under warranty by the developer, the cost of repairing the defect when performed by the District and the damages caused by the defect will be billed to the developer.

(h) Conveyance of Water and Sewer System Improvements. Upon completion of the construction of the water and sewer improvements, upon final approval by the District, and upon the water and sewer system improvements being placed into service, the water and sewer system improvements shall immediately become the property of the District regardless of whether or not a formal written conveyance has been made. The developer and any other persons paying the cost of constructing such improvements shall execute all written instruments requested by the District necessary to provide evidence of the District's title to such improvements, including obtaining any lien releases from the material suppliers and subcontractors of the developer and/or its contractor. The water and sewer system improvements shall become the property of the District free and clear of the claims of any persons, firms, or corporations.

## 6. Assessments and Collection of Fees and Charges:

(a) New Development Administrative Fee. The developer shall pay the District an

Administrative Fee to cover the administrative, inspection, engineering, legal and other expenses incurred by the District related to making water and sewer service available to the development. The Administrative Fee shall be paid on or before the execution of the Water Service Agreement and Sewer Service Agreement. For developments which request water and sewer service for a larger new development, the application fee paid under Section 2(c) shall be credited against the Administrative Fee.

(b) New Development Water Supply Charge. A water supply charge shall be submitted to the District for every new connection to the District's water supply system and also by customers who change their meter size to a larger meter, which shall be considered a new connection. A New Development Water Supply Charge is a one-time charge paid by the developer to the District to compensate the District for the additional groundwater supply from the Borrego Valley Groundwater Basin required to supply the new connection with potable water for the life of the new development. This New Development Water Supply Charge may be provided to the District by the developer in the form of water credits, production credits, or in the case of an adjudication, in water rights that the District shall retire from further use, as described in the Schedule of Fees and Charges to this Policy for Water and Sewer Service to New Developments, as amended and further explained in the Demand Offset Mitigation Water Credits Policy, as amended.

(c) New Development Impact Fee for Sewer and Wastewater Treatment Infrastructure (Sewer Capacity Fee). A Sewer Capacity Fee shall be paid on all new connections to the District's sewer system. Sewer Capacity Fees are one-time charges assessed for new sewer customers to recover a proportional share of the capital costs incurred to provide service capacity to new customers. These charges shall be imposed to fund sewer system infrastructure improvement costs reasonably related to new development. The Sewer Capacity Fee shall be paid on or before the execution of the Sewer Service Agreement.

(d) New Development Connection Fee (Connection Fee). The Connection Fee is based on the actual cost of the materials required for a new meter service. The Connection Fee shall be paid prior to the time actual water and sewer service is established to each new connection. Residential connections using 3/4" or 1" meters shall pay a standard Connection Fee that includes allocated, per connection, direct labor costs, materials, supplies, and equipment expenses and an allowance for indirect costs. All other connections using larger size meters will pay a custom Connection Fee based on the direct and indirect costs and expenses particular to that connection. If a customer changes to a smaller meter, no credit for any Connection Fee previously paid will be provided for a smaller meter

(e) No refunds. The developer shall have no right to recover any fees or charges paid to the District or any right to recover any part of the costs and expenses incurred in installing water system improvements or sewer system improvements for the development.

(f) Schedule of Fees and Charges. A current published schedule of fees and charges, as amended from time-to-time by the District, shall be used to determine the fee amounts assessed for each new development.

7. Approval of Final Plat

The District will not sign a "Final Plat" of the development for submission to the appropriate Planning Commission until the water and sewer system improvements for the development have been constructed, inspected and accepted for use by the District or until a performance bond secured by an irrevocable bank letter of credit issued by a bank with offices in San Diego County, California, or secured by other security specifically approved by the Board of Directors has been posted equal to the estimated cost of all necessary improvements and in favor of the District, the Water and Sewer Service Contract has been fully executed, and all applicable fees have been paid. If the development is not a subdivision, the applicable fees must be paid at the time the contract for water and sewer service is signed.

8. Easements

(a) A minimum exclusive easement twenty (20) feet in width must be conveyed to the District for water and sewer main construction and exclusive easements for other water and sewer system improvements must be conveyed to the District as required by the District. All water and sewer lines that are to become the property of the District are to be located off the public right-of-way and within these exclusive easements on private property. All exceptions are to be specifically approved by the Board of Directors or its delegatee. In all such cases where the Board of Directors or its delegatee approves water or sewer line construction within public rights-of-way, the developer shall obtain consent from the political entity having authority over such rights-of-way for such construction.

(b) The expenses of obtaining, preparing and recording easements needed for water and sewer system improvements for the new development will be paid by the developer, including but without limitation, the consideration paid to the landowner. In the event the District must exercise its power of eminent domain to acquire any such easement, the developer will pay all costs, expenses, appraisal fees, expert fees and damage awards for which the District becomes liable, on demand, including its attorney's fees.

(c) The easement grant must be on such terms and in such form and content as approved by the District.

(d) The developer is responsible for acquiring all such easements for both on-site and off-site water and sewer system improvement construction prior to the commencement of water and sewer system improvement construction.

9. Real Property Acquisition

In the event real property must be acquired for the installation of a water storage tank, a sewer treatment system, a pumping station or other water or sewer system improvement for the development, the expenses of obtaining, preparing and recording the real property will be paid by the developer, including, but without limitation, the consideration paid to the land owner. In

the event the District must exercise its power of eminent domain to acquire any such real property, the developer will pay all costs, expenses, appraisal fees, expert fees and damage awards for which the District becomes liable, on demand, including its attorney's fees.

10. Meters

(a) The developer shall pay for all water meters in the development, and the District shall install all residential water meters. The developer or lot owner at their expense shall install commercial water meters, defined herein as any meter greater than one (1) inches.

(b) Each family residence or each duplex or other property shall be served with a separate water meter not smaller than  $\frac{3}{4}$  inch in size, except where prior arrangements have been made with the District for apartment complexes, other types of multi-family dwellings, or businesses. In the event an existing water meter serves an apartment complex and/or other business property with units owned and/or occupied by more than one individual, firm, or corporation, the same shall be separated so as to have a meter for each ownership or occupant.

11. Permits

Before beginning construction, the developer or its contractor shall obtain all necessary permits as required by law. Such permits include, but are not limited to, those from State of California and the county highway department in which the development is located.

12. Resolution of Disputes

Any controversy or claim arising out of or relating to this Policy or the Water and Sewer Service Contract, or the breach thereof, shall be submitted to the Board of Directors, which may appoint a subcommittee of the Board to negotiate the controversy or claim. If the Board is unable to resolve the dispute by negotiation, the dispute shall be submitted to a mutually acceptable mediator. Mediation shall be required before either party may proceed to any other method of dispute resolution. Costs for mediation shall be shared equally between the parties. The decision of the mediator shall not be final or binding unless agreed to in writing by the parties. All mediation proceedings, results and documentation, shall be non-binding and inadmissible for any purpose in any legal proceeding (pursuant to California Evidence Code sections 1115 through 1128) unless such admission is otherwise agreed to in writing by both parties. If the parties are unable to resolve the dispute by mediation, the dispute shall next be submitted to arbitration administered by the American Arbitration Association under its Commercial Arbitration Rules, and judgment on the award rendered by the arbitrator(s) may be entered in any court having jurisdiction thereof. All water and sewer service contracts shall contain a dispute resolution clause which requires that any controversy or claim arising out of or relating to the Water and Sewer Service Contract, or the breach thereof, shall be settled using the process set forth in this Section 12.



## SCHEDULE OF FEES AND CHARGES FY 20165-176

### Existing "New Water and Sewer Charges" in BWD Service Areas

Presently there are approximately 2,100 undeveloped lots that could be served with water service from existing infrastructure. Presently, certain areas of the District have been charged different amounts due to historical agreements as follows:

ID-1 (Rams Hill): The water capacity fee has been paid and service laterals installed for new meters on the existing lots. Currently we charge ~~\$640~~\$795 for a 3/4" and ~~\$930~~\$735 for a 1" meter service. This covers a \$340 "turn-on" fee, the meter, meter box, customer shut off valve and the labor to install the new meter. One customer was granted a 2" residential meter by the Board in 1999 all other residential meters are either 3/4" or 1". New sewer connections are charged \$200 plus a \$50/EDU inspection fee. Monthly sewer fees are ~~\$38.78~~26.75.

ID-2: The Town Center Sewer serves the downtown area along Palm Canyon Drive from Palm Canyon Resort to the Elementary School. Also included is the La Casa del Zorro (aka Borrego Ranch) Resort. There are 1000 EDU's assigned to this system of which ~~336~~416 are being used (user) and ~~735~~73 are being held for future use (holder). The District has 226 EDU's available for sale at a price set by the Board of \$3,040. Holders may sell their EDU's at negotiated prices with willing buyers. The District occasionally surveys the holders to see if EDU's are available for private sales. "Holder" monthly fees are ~~\$24.76~~19.42 and once they become also a "user", the fee increases ~~by \$10~~to \$45.10. New connections are charged a \$712.80/EDU capacity fee and a \$50/EDU inspection fee. All sewer connections are performed at customer's expense by a District approved contractor. These fees are set by contract but can be adjusted to operating costs by a vote by all holders of EDU's.

ID-3 and 4 (Deep Well Trail and old Borrego Springs Water Company service area): Water mains in these areas are normally located in the shoulder of the road, in the right-of-way, yet off of the pavement. The new meter charge in these areas depends on the location of the new service to the existing water main. New meters located on the same side of the street as the water main require a "short lateral" and those across the street a "long lateral". Certain areas of the District where the water main is located in the paved street classify as a "long lateral". The maintenance crew utilizes a boring device to feed the new service lateral under the pavement on long laterals which is more labor intensive but does not require re-paving after an installation. The current fees are ~~\$5,516,040~~ for a 3/4" short lateral, ~~\$7,460,165~~ for a 1" short lateral, ~~6,876~~\$5,440 for a 3/4" long lateral and ~~\$8,820,565~~ for a 1" long lateral. The breakdown of these fees are listed on page 14 of this document. ~~\$2,530 connection fee, \$340 turn-on fee, either \$500 for short lateral or \$1,900 for a long lateral and either \$70 for a 3/4" customer shut-off valve or \$95 for a 1" customer shut-off valve~~. Customer shut-off valves are an important feature and we also will provide them ~~to existing customers~~ for the cost of the part, no labor charge. The customer shut-off saves us money, and possibly the customer, in the long run. When not installed, the customer is tempted to turn-off the District angle meter stop (forbidden by the administration code) or contact the "duty operator" to turn off and turn back on after

plumbing/irrigation repairs are complete. If the angle meter stop is compromised, the water main has to be excavated and the customer can be charged for the repairs. After hours duty operator "call outs" are costly to the District in overtime expense. Many water Districts found cost savings by installing the customer shut-off valve free of charge, but we found it more prudent to only charge for the part and install the valve free of charge.

ID-5: This area is the old Borrego Springs Park Community Services District area of Club Circle and the Borrego Springs Resort. As part of the consolidation agreement, we are required to charge \$3,500 each, for new service (water and sewer combined). One half of this money is returned to the developer, ~~Cameron Brothers Construction Co.~~ as per the agreement. The service laterals on Foresome Drive were installed with poly vinyl pipe which have proven to be substandard in our desert conditions. New service requires the removal of this pipe and replaced with copper service laterals which are charged on a "time and material" basis. All sewer connections are performed at customer's expense by a District approved contractor. Only one connection has been made since the consolidation of the two districts.

The monthly rates are listed as follows:

ID-1; ~~\$38.7833.56~~/mo. plus portion of \$66/parcel availability fee collected through the annual property taxes  
Connection fee of \$200 plus \$50/EDU inspection fee

ID-2; ~~\$24.7619.42~~ (holder) plus ~~\$20.3410~~ (user) totaling ~~\$45.1029.42~~/mo.  
Connection fee is \$712.80 per EDU plus \$50/EDU inspection fee

ID-5; ~~\$45.1062.62~~/mo.  
Connection/capacity fee collected is \$3500, 1/2 is directed to the developer, ~~Cameron Bros. Construction Co.~~ and 1/2 to BWD per EDU. Meter installation is charged on "time and materials" only.

Both ID-2 and ID-5 require lifting the effluent from the newly built Lift Station (capital improvement of \$680K in 2011) on Borrego Valley Rd to the ~~RMWWTPRHWF~~.

All of these sewer charges were developed based on developer "buy-in" or other such arrangement. For this reason, existing platted lots will continue with the above fee structure. The total number of existing platted lots involved should not require any further improvements to the existing infrastructure; however, this can be reviewed in subsequent years if needed. Any new development will be required to pay the new calculated sewer capacity fee of \$8,000 per EDU plus any additional new infrastructure required specifically for the new development which will be determined by the District Engineer.

A study is also eventually needed to evaluate at what point the ~~RHWWTP-RHWF~~ can generate reclaimed water supply and where the reclaimed water could be utilized if the Rams Hill ~~Golf~~ golf course is not in operation.

Historically, we have utilized the following calculations for EDU breakdowns.

Single Family Residence (SFR) =	1.0 EDU
Casitas/Guest House with SFR=	0.5 EDU
Mobile Home (in a park) =	0.5 EDU
Recreational Vehicle (in a park) =	0.25 EDU

These ratios were based on overall housing footprint (property size, human capacity, etc.). A mobile (manufactured or modular) installed on a lot designed for a single family residence is considered a single family residence due to the lot size and potential of developing extensive landscaping. Units installed in a designated mobile home park are situated on small lots where the landscaping potential is significantly less. A "casitas" is a small single family residence less than 800 square feet, is a small development with common landscaping.

New commercial and multiple unit projects will need to be reviewed in a case-by-case basis. There are too many factors to apply a general fee schedule to these types of installation. Historically, an engineering deposit is required to recoup District funds expended. The amount of deposit will vary depending on the scope of the project but a minimum fee of \$2,500 would be appropriate.

### **Water Credit Policy**

The Water Credit Policy was first established as a 3:1 groundwater mitigation in 2005. In 2007 the 3:1 was reduced to a 2:1 with the premise that one would satisfy the County of San Diego requirements and one for the Borrego Water District. On February 24, 2016, the District enacted Resolution 2016-01-01 requiring all new development to address the regulatory restrictions and requirements of the Sustainable Groundwater Management Act of 2014 and adopted a 4:1 groundwater mitigation policy. The water credit policy for new development consists of 4:1 to satisfy the Borrego Water District Demand Offset Mitigation Water Credit Policy. Unless and until San Diego County adopts a parallel policy, all new subdivisions must comply with the County's current policy of 1:1. The Water Credit Policy will be administered as follows:

#### **New Development requiring San Diego County approval:**

- 1 Water Credit due with County discretionary permit process
- 3 Water Credits due ~~when District signs "Required Agency Clearance Letter" for new home construction~~ upon purchase of new water meter/s.
- 4 Total Credits**

#### **New Single Family Residence construction on existing lot:**

- 4 Water Credits due upon purchase of a new water meter. ~~when District signs "Required Agency Clearance Letter" for new home construction~~
- 4 Total Credits**



### New Water and Sewer Connection Fees for New Subdivisions:

The proposed "capacity fee" has been calculated by dividing the total water system asset \$11,041,479.26 (as of June 30, 2012), minus \$2,775,000 (existing infrastructure debt from the ID4 2008 Certificates of Participation) by the total existing water meters utilizing the American Water Works Association (AWWA) meter sizing factors. This equates to \$1,841.17 but for simplicity, it would be appropriate to round that number to \$1,850/EDU.

Applying the same metering factor to new installations would result as follows:

3/4" meter	x 1.5 meter factor	= \$2,775
1" meter	x 2.5 meter factor	= \$4,625
1-1/2" meter	x 5 meter factor	= \$9,250
2" meter	x 8 meter factor	= \$14,800
3" meter	x 15 meter factor	= \$27,750
4" meter	x 32 meter factor	= \$59,200
6" meter	x 85 meter factor	= \$157,250

Using the same formula as water, dividing sewer assets (\$5,505,105.59) by existing EDU's (689) equates to \$7,989.99 or for our purposes, \$8,000/EDU. Any proposed development will have to complete an analysis of increased flow to the Ram Hill Wastewater Treatment ~~Plant-Facility~~ (RH~~W~~T~~FP~~) except the remaining undeveloped lots in the Rams Hill community who built the facility. Town Center Sewer EDU "holders" have also been worked into the RH~~W~~T~~PF~~ expansion calculations through the costs outlined in the Town Center Sewer Agreement. Sewer customers in ID-5 are required to pay \$3,500 (combined water and sewer) 1/2 of this amount is for reimbursement to the developer, ~~the Cameron Bros. Construction Co.~~ per prior agreement. Unplatted lots (not a County approved buildable lot) in ID-5 will have to go through the permit process and associated engineering study for R~~H~~M~~W~~T~~FP~~ capacity issues.

Due to the number of historical agreements in the various service areas, it is proposed that new connections for existing platted lots in ID-1 be exempted from the new capacity fee. Existing lots in ID-1 have already been assessed capacity fees and the infrastructure for the new meter installations are in place. Existing lots in ID-5 will be required to pay the historical capacity fee of \$3,500 (water and sewer combined) of which 1/2 will be paid to the Cameron Bros. developer, ~~as~~ per the consolidation agreement. The existing infrastructure for the new meter installations that ~~was~~ were installed by the developer does not meet the requirements of the District and therefore ~~they~~ will be charged the "actual installment costs" ~~and~~ in ID-3 and ID-4.

**Subdivisions:**

"Will Serve" Letter - first step in County permitting process	\$50/Letter
"Will Serve" Conditions Letter - outlining system requirements	\$2,500 engineering deposit
Engineering Plan Review	\$5,000 engineering deposit
Final Map	Water Credit & Capacity
Fees	
One water credit per EDU	
Capacity fee of \$1,850/EDU times metering factor	

**Commercial:**

Case-by-case basis on fixture unit count and approved landscaping plan

**Water Credits:**

The water credit policy for new development and subdivisions consists of a 4:1 policies, one water credit to satisfy the County New Subdivision Policy and three credits to satisfy the Borrego Water District Demand Offset Mitigation Water Credit Policy. For existing platted lots in the area, 4 water credits are required to fulfill the District's policy

For a list of approved water credits see Demand Offset Mitigation Water Credits Policy.

**Schedule of New Water and Sewer Installation Charges for a Single Family Residence for FY 20165 & FY 20176**

**New Water and Sewer Service on Existing Platted Lot in ID-1:**

(Note: Sewer Fees not applicable to lots in the "Estates" Community where lots are on septic systems)

- Four Water Credits
- Capacity fee and lateral installation pre-paid by developer
- Sewer Connection Fee \$200
- Sewer Inspection Fee \$50
- All sewer connections are performed at customer's expense by District approved contractor
- Connection Fee
  - 3/4" meter = \$205
  - 1" meter = \$340
- \$340 Administrative Fee

**Total 3/4" Charge = \$795.00**

**Total 1" Charge= \$930.00**

*Larger meters will be reviewed on a case-by-case basis*

**New Sewer Service for "holders" of Town Center Sewer EDU's in ID-2:**

- New service must be holder in good standing of ID-2 EDU's (contact District office for Town Center Sewer EDU information)
- Capacity Fee of \$712.80 per EDU
- Inspection Fee of \$50/EDU
- All sewer connections are performed at customer's expense by District approved contractor

**Total Fees due District \$762.80/EDU**

**New Water Service on Existing Platted Lot in ID 3 or ID-4:**

- Four Water Credits
- Capacity fee (\$1,850) with metering factor:
  - 3/4" meter x 1.5 meter factor = \$2,775
  - 1" meter x 2.5 meter factor = \$4,625
- Connection Fee
- Short lateral charge (parcel located on same side of street as the water main)
  - 3/4" meter service = \$2,401.05 or 1" meter service = \$2,495.10
  - Long lateral charge (parcel located on opposite side of street from water main)
    - 3/4" meter service = \$3,760.82 or 1" meter service = \$3,854.87
- Administrative Fee of \$340

**Total 3/4" charge with short lateral:**  $2,775 + 2,401.05 + 340 = \$5,516.05$   
**Total 3/4" charge with long lateral:**  $2,775 + 3,760.82 + 340 = \$6,875.82$   
**Total 1" charge with short lateral:**  $4,625 + 2,495.10 + 340 = \$7,460.10$   
**Total 1" charge with long lateral:**  $4,625 + 3,854.87 + 340 = \$8,819.87$

*Larger meters will be reviewed on a case-by-case basis*

**New Water and Sewer Service on Existing Platted Lot in ID-5:**

- Four Water Credits
- Capacity Fee of \$3,500 (water and sewer combined, existing agreement where 1/2 is paid to the developer)
- Sewer Inspection Fee of \$50
- Connection Fee
  - Long lateral charge (water mains in street)
    - 3/4" meter service = \$3,760.82 or 1" meter service = \$3,854.87
- \$340 Administrative Fee

**Total 3/4" charge:**  $3,500 + 50 + 3,760.82 + 340 = \$7,650.82$   
**Total 1" charge:**  $3,500 + 50 + 3,854.87 + 340 = \$7,744.87$

*Larger meters will be reviewed on a case-by-case basis*

**Policy: Who pays for growth?**

**Background:** There are always discussions about responsibility for costs when a developer seeks to add an area of water and sewer service to a new development. As a general rule, the Borrego Water District (BWD) requires the development to pay its own way, desiring not to subsidize growth. This is only fair to existing customers. Sometimes, however, BWD desires to extend a water or sewer line at its own cost whenever the result will be an improvement to the system. Because these are differing directions, the differences can sometimes become blurred. BWD has attempted to resolve the issues with its developer policy. This policy will need to be reviewed from time to time to determine its applicability. What is needed for effective strategic planning is a statement of policy on the subject affirming the general direction.

**Policy:** It is the policy of the Borrego Water District (BWD) to encourage responsible growth by requiring new developers to install water and sewer connector lines at the developer's expense, in addition to the assessment of developer charges for each new connection to pay for any improvements required to the existing BWD system and the use of existing system capacity. Participation in costs by BWD will occur only when BWD is convinced such connector lines will add further benefit to the District.

BORREGO WATER DISTRICT  
BOARD OF DIRECTORS MEETING – MARCH 14, 2017  
AGENDA BILL II.D

March 8, 2017

**TO:** Board of Directors, Borrego Water District  
**FROM:** Geoff Poole, General Manager  
**SUBJECT:** Concurrence on Nominations of Candidates for ACWA/JPIA Board/Executive Committee – H Ehrlich

**RECOMMENDED ACTION:** Approve Director Ehrlich’s recommendations to support nominations for three candidates for ACWA/JPIA Executive Committee

**ITEM DESCRIPTION:** Periodically, ACWA/JPIA elects new members of its Executive Committee and that time is now for 4 positions including several incumbents. Director Ehrlich has reviewed the candidates and is recommending the following non-incumbents be supported in their nominations:

1. Fred Adjarian – El Toro Water District
2. Paul E. Dorey – Vista Irrigation District
3. Kathleen J. Tieg - Cucamonga Valley Water District

Once all nominations are received by March 24, 2017, the ballot for the election will be distributed at the Annual ACWA/JPIA meeting in May. The BWD representative on the ACWA/JPIA (Ehrlich or Poole) will cast the ballot at that time.

**IMPACT:** N/A

**ATTACHMENTS:** None

BORREGO WATER DISTRICT  
BOARD OF DIRECTORS MEETING – MARCH 14, 2017  
AGENDA BILL III

March 10, 2017

TO: Board of Directors, Borrego Water District  
FROM: Geoff Poole, General Manager  
SUBJECT: INFORMATIONAL ITEMS – SUMMARY

- A. **Summary of March 6<sup>th</sup> GSP Advisory Committee Meeting** – G Poole: The first meeting of the Borrego Valley Groundwater Basin Advisory Committee was held on March 6<sup>th</sup> and those of us who attended are invited to share their comments/observations.
- B. **2017 Town Hall Logistics** – L Brecht: Director Brecht requested that this item be placed on the Agenda. A copy of the Draft Agenda is attached. (pg 182)
- A. **Risks to SGMA** – L. Brecht: Director Brecht requested that the Board discuss potential risks to SGMA
- B. **Directors Sexual Harassment Prevention Webinar** – April 2 and 6, 2017 – ACWA/JPIA is conducting webinars on this topic and information is attached (pg 183)
- C. **Update Depth Dependent Water Quality Sampling** – G Poole: USGS staff and BWD (Staff and O and I Committee) had an opportunity to continue the discussion on the possibility of conducting depth dependent sampling. The well that has the potential to produce the best results is #12 and that well is being tested in the very near future to determine its pumping efficiency. Once the efficiency results are in, a determination will be made on the timing of the cleaning/rehabilitation. In the meantime, USGS and BWD staff will continue to work on the technical issues of determining if there is adequate room in the casing to place the sampling tube, find a place to put the water during high flow pumping and a few other issues. If Well 12 proves to be infeasible other alternative locations, including private wells, will be considered for this project. Staff will keep the Board updated on the efficiency results.
- D. **Plan of Action: Risk Management Analysis** – G Poole: The Risk Management Committee met on March 8<sup>th</sup> and directed staff to prepare a Plan of Action to address, Cyber Security, Power Back-up, Physical Security of BWD Facilities and the BWD Emergency Plan review. Staff will return with a Plan of Action at the March 22<sup>nd</sup> meeting.
- E. **BWD 12 month Events and Planning Calendar** – G Poole: Attached (pg 184-185)

## **2017 Borrego Town Hall Draft Agenda**

Date: March 29, 2017

Time: 4:00 to 5:30

Location: Borrego Performing Arts Center

1. Greetings and Introductions: Beth Hart, President BWD
  - a. DWR
  - b. BWD Board and Staff
  - c. GSP Core Teams
  - d. Borrego GSA/P Advisory Committee Members
  
2. Sustainable Groundwater Management Act: Jim Bennett & G Poole
  - a. Overview of SGMA and Current Status of Borrego GSA/P
  - b. Schedule of GSP Process and Stakeholder Participation Plan
  - c. GSP Website
  - d. Introduce Consulting Engineers
  
3. Update on BWD Finances – Lyle Brecht, BWD
  - a. Annual Report Summary
  - b. Prop 218 Rate Projections
  
4. Upcoming CIP projects (900 Tank, WWTP etc...) – J. Tatusko
  
5. Update on BWD Operations – Geoff Poole, BWD
  - a. Water Consumptions Patterns
  - b. New Water Bill Format
  - c. New BWD Website
  
6. Q and A – Beth Hart, BWD
  
7. Closing Comments – Beth Hart, BWD



## JPIA Offers Sexual Harassment Prevention Class for Managers and Board Members via Webinar

This course is designed to help members comply with current laws requiring Managers, Supervisors and Board Members to take sexual harassment prevention training every two years. Upon completion of the course, you will: understand the state and federal sexual harassment laws; recognize early signs of sexual harassment and how to respond; learn how to promote and maintain respectful communication; understand how to investigate and resolve sexual harassment complaints; and meet the requirements established by AB 1825, 2053 & 1661. There is no cost for attending this webinar. It is another benefit of membership in JPIA.

---

### Webinar Schedule:

Thursday, April 6, 2017 from 10AM to 12PM (completion of 2 hours of training required)

Wednesday, May 2, 2017 from 1PM to 3PM (completion of 2 hours of training required)

---

Participate individually or as a *group*. **For individuals**, register for the webinar [here](#). Once you complete the class, you will receive credit automatically. **For groups**, one person can register for the webinar [here](#) and it can then be projected for the group to view and complete together. Signed roster with date, time, names and signatures will be required to receive credit for a group training. Email rosters to [training@acwajpia.com](mailto:training@acwajpia.com)

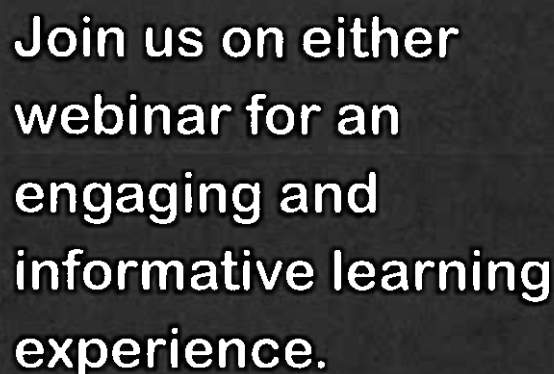

Join us on either  
webinar for an  
engaging and  
informative learning  
experience.

For further information contact JPIA Training Department at [training@acwajpia.com](mailto:training@acwajpia.com) or 800.231.5742





## **MARCH**

- **P & I PAYMENT FOR ID4 COP'S** - 1st half of payments due
- **ANNUAL EAR REPORT (CDHS)** – Due 3/31 for previous year
- **DISCUSS BUDGET PROCESS** – March 22nd
- **TOWN HALL MEETING – 3-29-17 from 4:00-5:30**

## **APRIL**

- **T2** – Raftelis spare capacity cost analysis
- **SURPLUS WATER ACTIVITY** – 4/1 Calculate Surplus Water Activity
- **PITNEY BOWES** – 4/1 Send letter of cancellation if desired
- **CASGEM** – Submit CASGEM water level data
- **BEGIN BUDGET PROCESS** – CIP meeting, draft budget document
- **GSP ADVISORY COMMITTEE** – April date not yet determined

## **MAY**

- **SURPLUS WATER ACTIVITY** – 5/1 Notify Rams Hill of Surplus availability
- **BUDGET** – Final Budget document/ FY Rate resolution
- **BUSINESS PLAN** – FY Budget and New Rates Approved

## **JUNE**

- **SANTIAGO ESTATE** – Occupancy Report Due
- **BUDGET** – Approval of Budget
- **INVESTMENT POLICY** – Investments policies restated
- **SPECIAL ASSESSMENTS / TAX BILL RESOLUTIONS TAUSSIG:**  
Special Assessments resolutions due

## **JULY**

- **T2 BORREGO** – 7/1/17 Establish water budget
- **COMPASS BANK** – 1<sup>st</sup> Payment due September 1<sup>st</sup>
- **GREEN DESERT LANDSCAPE** – Cost of water adjustment each July 1<sup>st</sup> with Cameron
- **XEROX** – Lease contract expires 7/2020
- **PITNEY BOWES POSTAGE MACHINE** – Lease expires 7/2017
- **CCR** – CCR to be distributed July 1<sup>st</sup>
- **BUSINESS PLAN** – New Rates go in to effect

## **AUGUST**

- **RAMONA DISPOSAL**  
CLUB CIRCLE - Contact RDS RE: Contract Renewal  
BWD Dumpsters – Contact RDS RE: Contract Renewal
- **AUDIT** – Begin Audit



## **SEPTEMBER**

- **P & I PAYMENT FOR ID4 COP'S** - 2nd half of payments due
- **CHECK FALLOWED PROPERTY FOR WATER USAGE** – Annual fallow property check
- **AUDIT** – Review Audit draft report

## **OCTOBER**

- **COMPASS BANK** - Payment due December 1<sup>st</sup>
- **CCR** – Mail CCR Certification Form
- **CAMERON BORS. WATER USAGE REPORT (GOLF COURSE) TO COUNTY**  
Send to County DPLU by 10/31

## **NOVEMBER**

- **CASGEM** – Submit CASGEM water level data
- **REPORT CONSERVATION LEVELS TO STATE** – Report Due

## **DECEMBER**

## **JANUARY 2018**

- Design Agenda for 2018 Town Hall Meeting

## **FEBRUARY 2018**

- **CLUB CIRCLE** - Option to renew lease by 2/28/2017
- **GREEN DESERT LANDSCAPING** - Discuss w/ Bob the option of continuing with contract 2/28/2021